

World Wide Radio Operators Foundation



High Performance
Receiving Antennas
for a Small Lot



Jose Carlos

N4IS

Sponsors



High performance receiving antennas for small lots

Basic concepts and practical aspects

- Directivity & gain
- Signal to noise ratio
- RDF antenna comparison for 1.8 MHz
- What a receiver antenna can do for you

New Receiving antennas

- What is a Horizontal Waller Flag
- Detuning TX antenna
- Common mode noise
- Conclusions

Dual loaded loop receiving antenna (resources back up slides)

- Historic evolution
- Beverage EWE FLAG DHDL QDFA
- Rotatable Rx antennas HWF VWF
- Constructions details



- NX4D Doug Waller QTH 1/5 acre city lot subdivision
- 309 countries heard on 160m
- 298 worked 2003 to 2016 40 zones since 2011
- Average of 2 new countries every! Month!
- Average of 24 new countries every! Year!
- 13 years in a row! >> <http://nx4d10.wix.com/waller-flag>

RX antennas directivity & gain

- It is all about signal to noise ratio

All we need is 3 dB SNR for CW and 8 dB for SSB

RX antenna has negative power gain and needs a preamplifier

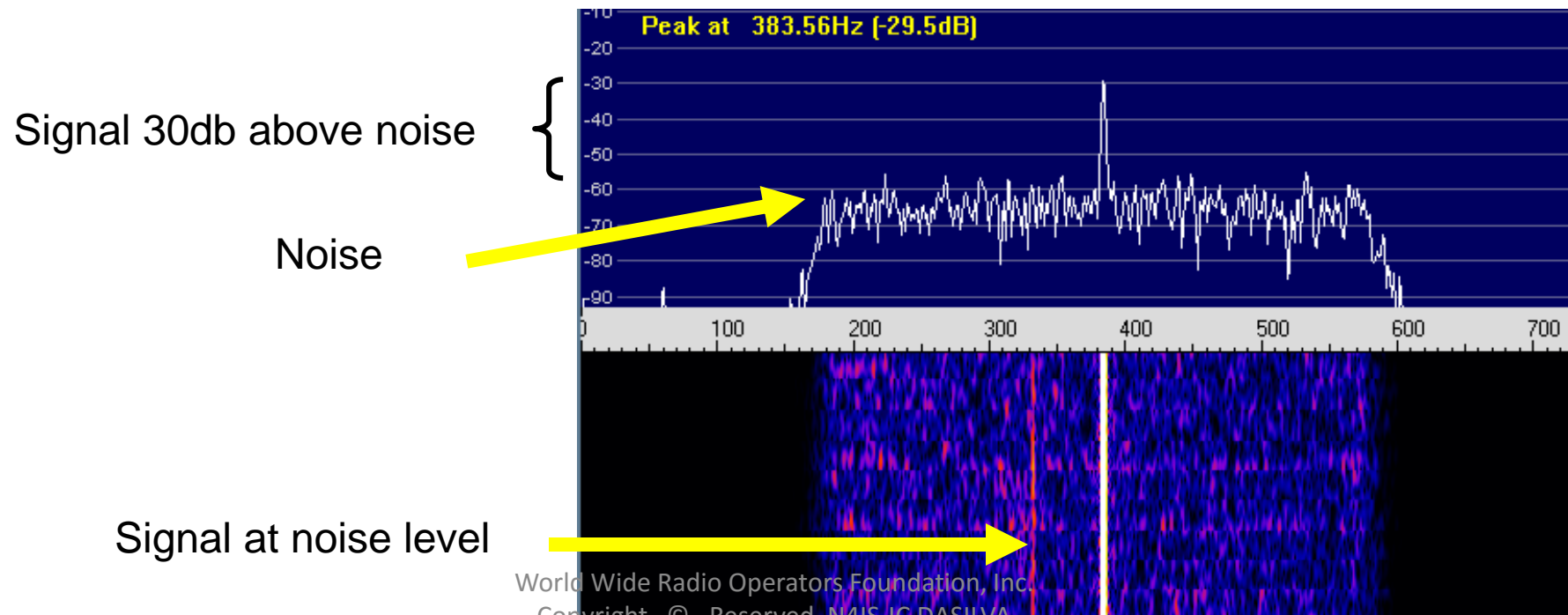

RX antennas directivity & gain

- The gain is the difference between an amplifier input and output intensity.
- Adding a 18 db. gain amplifier, the signal and the noise will increase 18db and the signal noise still will be the same.

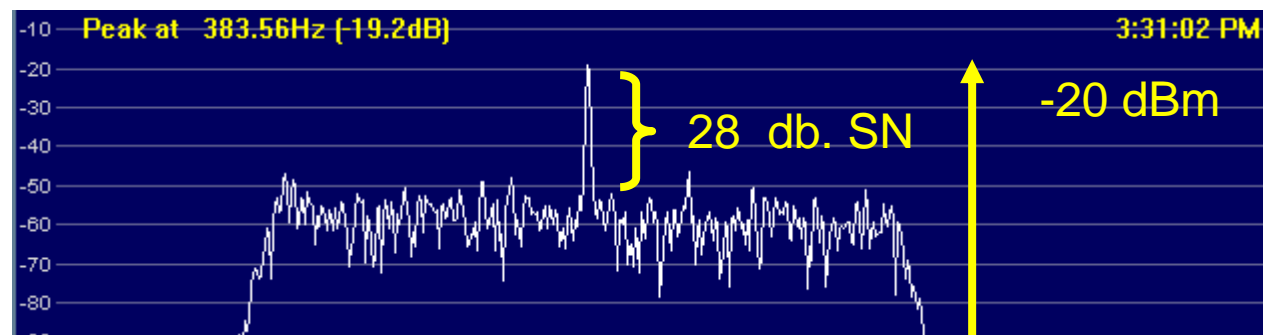

RX antennas directivity & gain

1840 KHz carrier received with vertical TX antenna

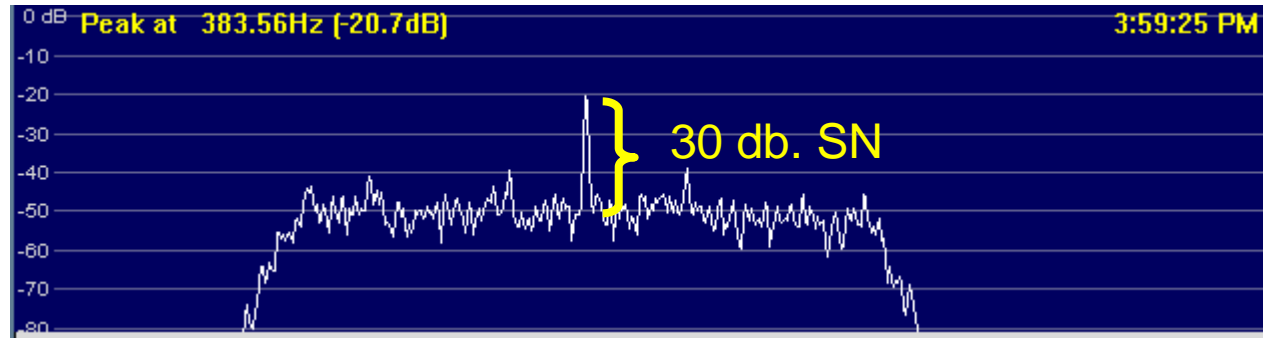

Same signal received with a Big Waller Flag

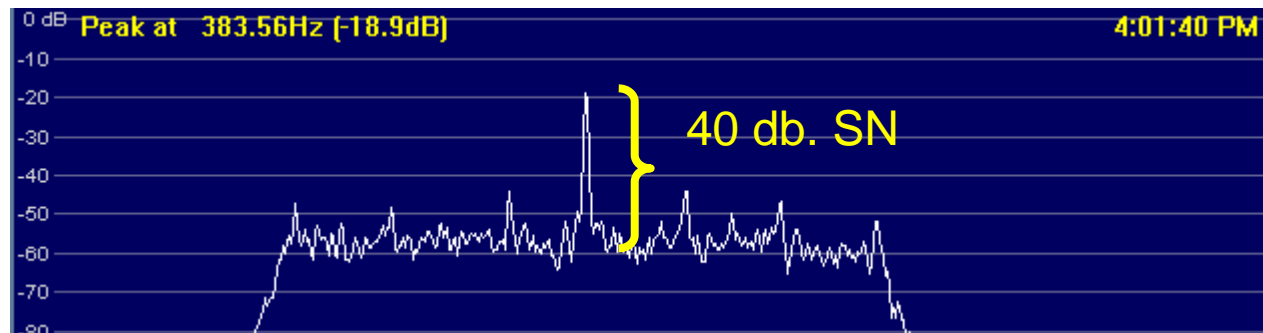

RX antennas directivity & gain

When the signal is above noise there is little difference on the audio. The receiver AGC will make the strong signal just more comfortable to copy but it should not be used for evaluation of the receiver antenna.

A good receiver antenna will provide copy of weak signals not present or buried in the noise on the transmit antenna

**Increasing the directivity
by 1 dB RDF the SNR
increases 1.5 to 2 dB**

Understanding directive antenna gain

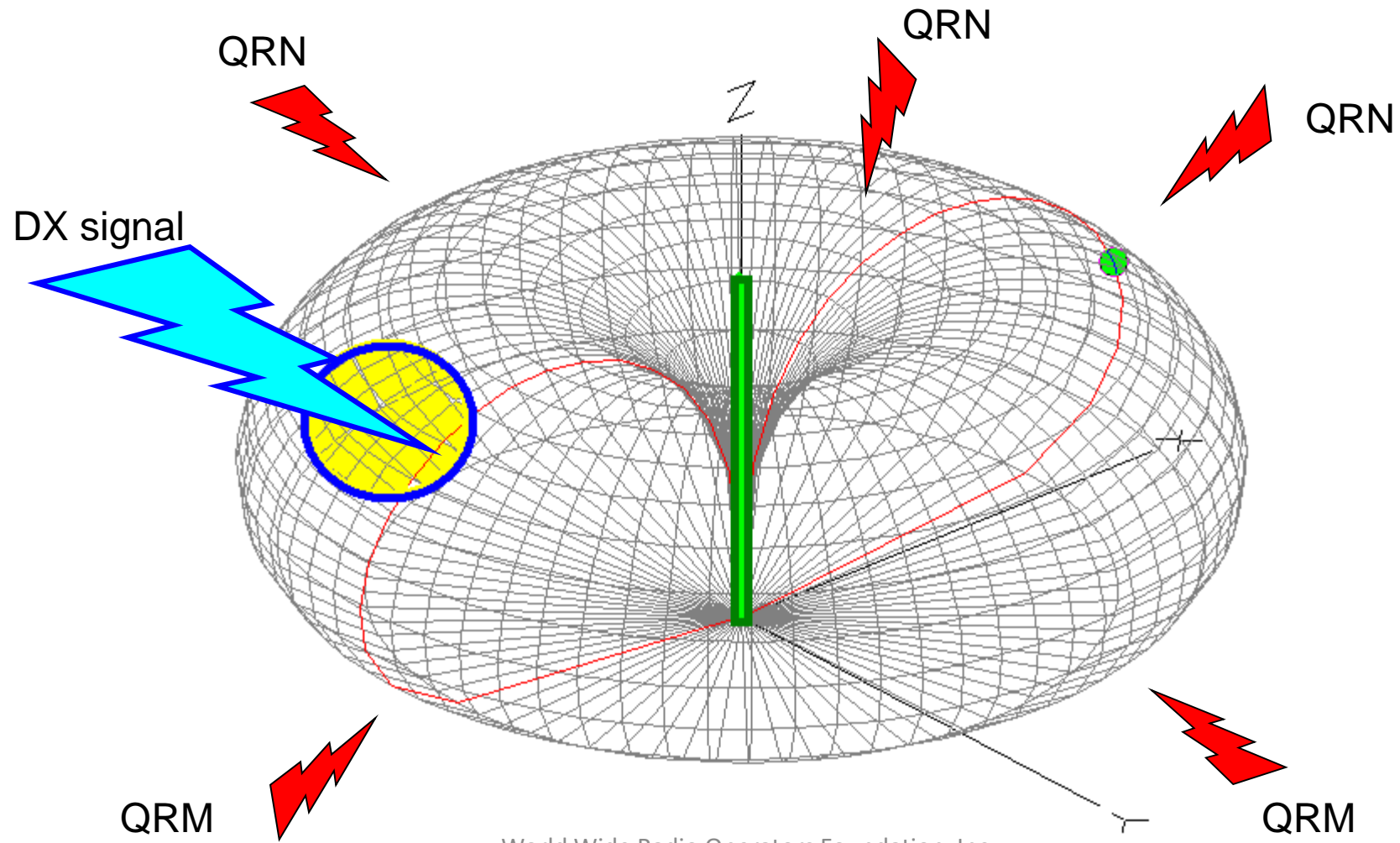

Understanding directive antenna gain

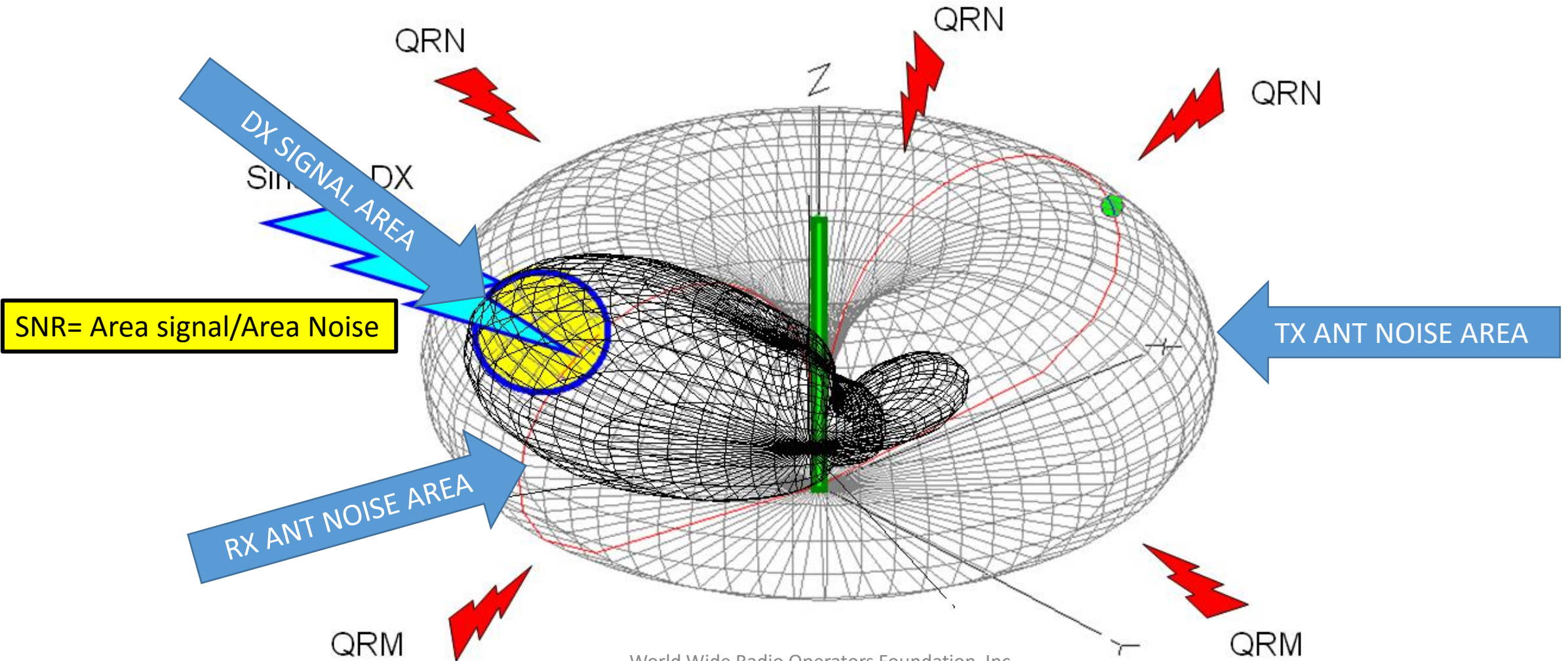

RDF calculation using EZNEC

- Directivity gain is the difference between Total Average gain and maximum antenna gain.
- W8JI Receive Directivity Factor > <http://www.w8ji.com/receiving.htm>
- “Edward C. Jordan Keith G . Balmain “(Electromagnetic Waves and Radiating Systems) 11.11 pg. 374 Antenna Gain . 1950
- On EZNEC it is easy to calculate RDF using 3D plot configuration

$$\bullet \text{RDF} = \text{Gain} - \text{Average Gain}$$

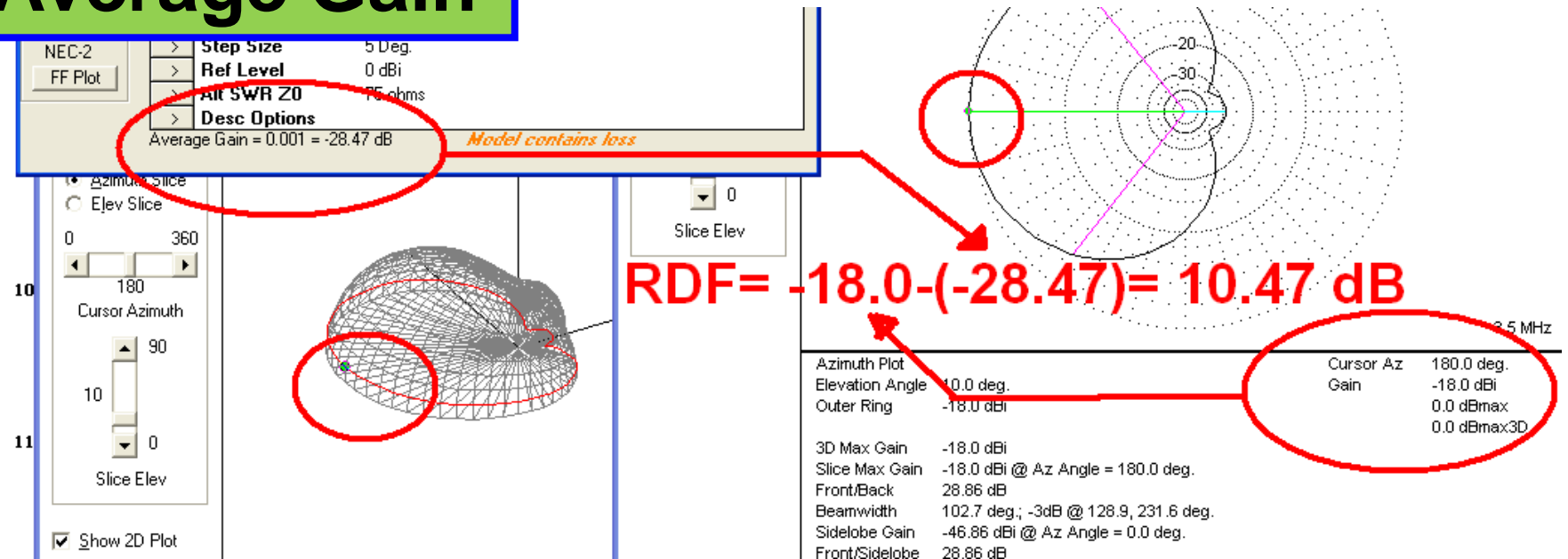

$$\text{RDF} = -18.0 - (-28.47) = 10.47 \text{ dB}$$

RDF antenna comparison for 1.8 MHz

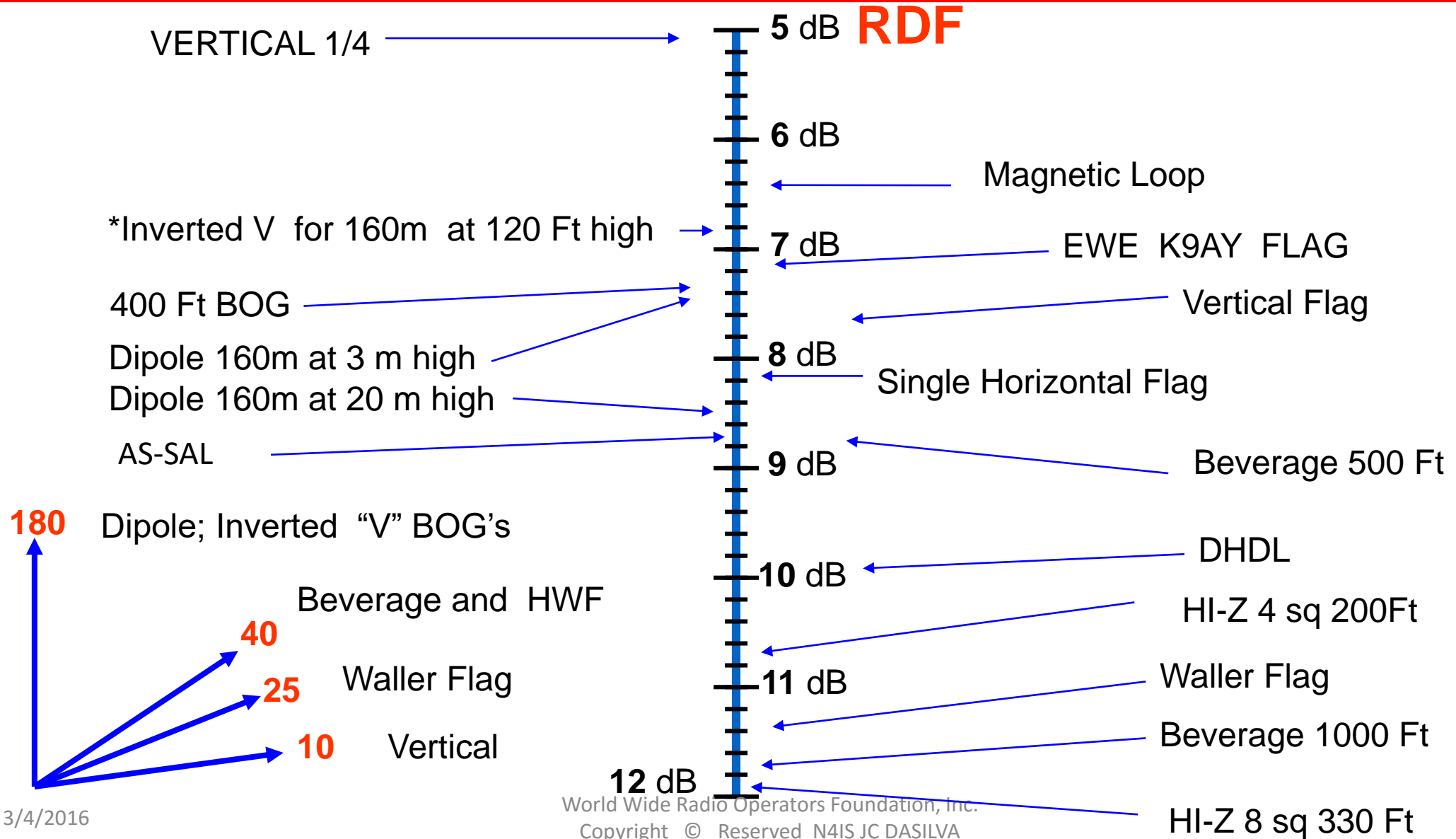

RDF from well know antennas

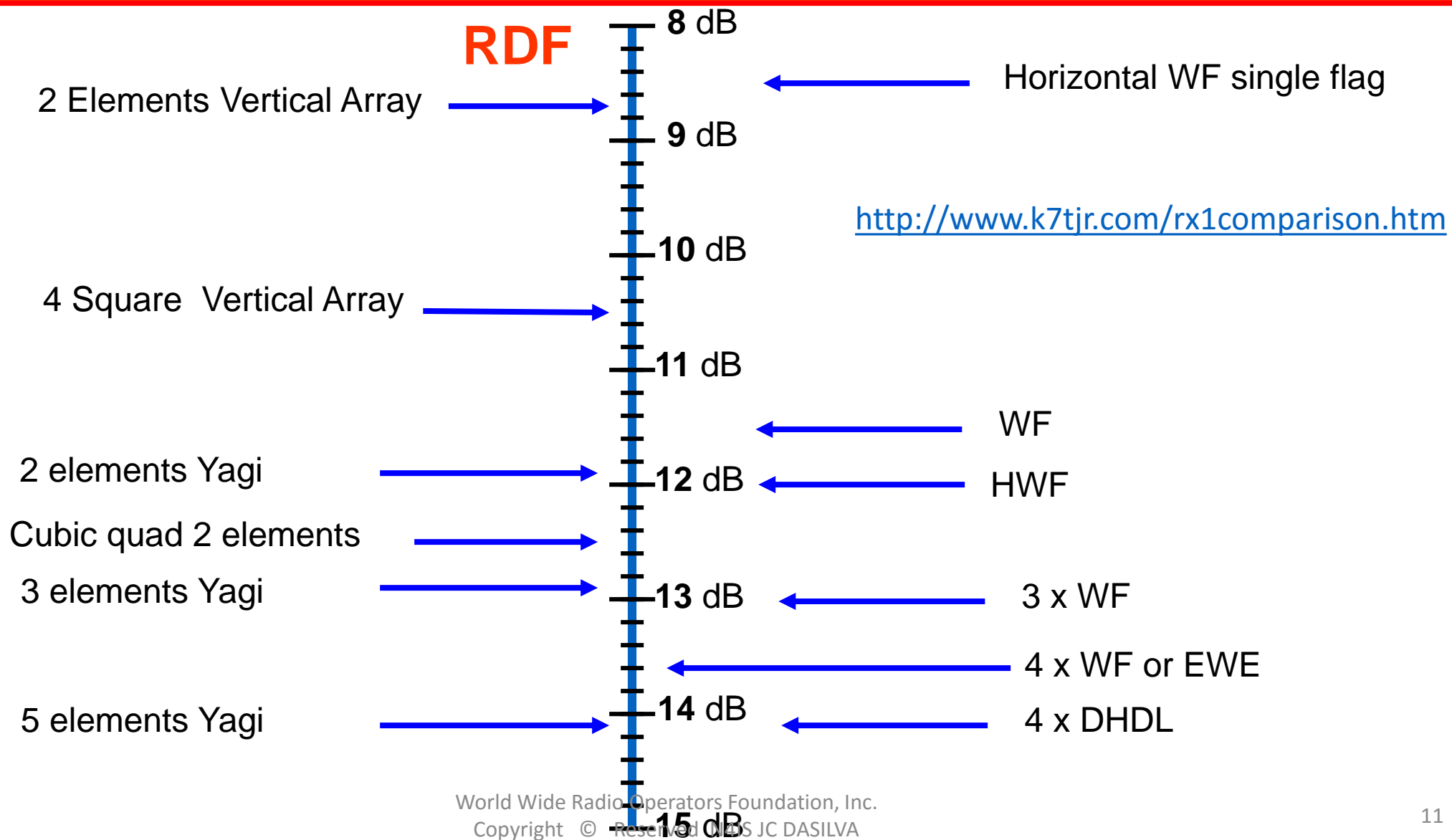

What RDF really can do for you ???

FIRST STEP > FLAG EWE K9AY 7 to 8 dB RDF

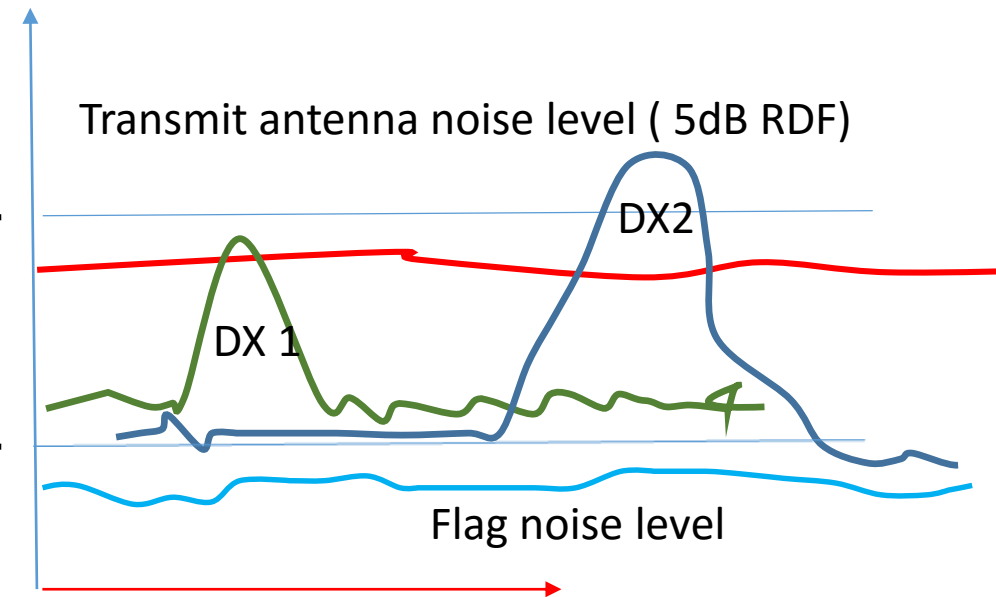
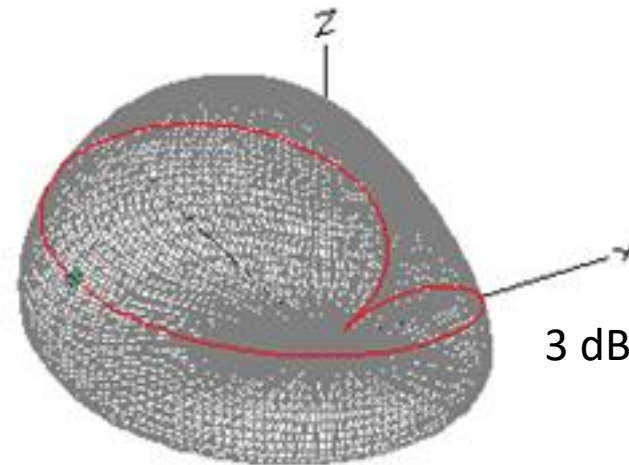
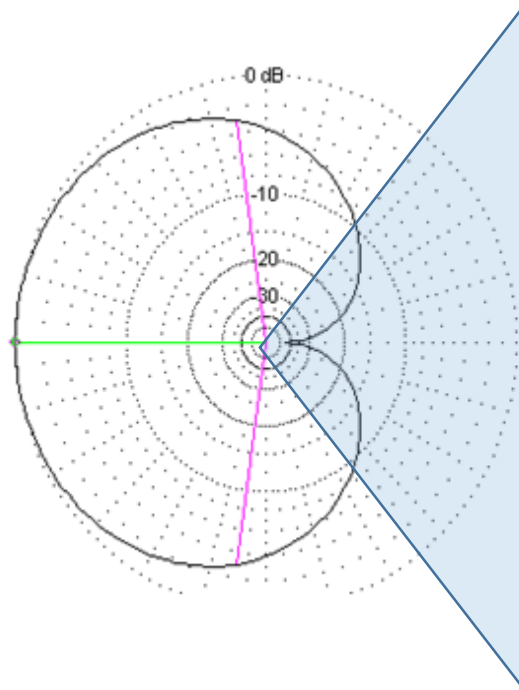

1. Vertical RDF 5 dB > FLAG RDF 7 dB (2) = 3 to 4 dB improvement on (1.5to 2 dB SNR for 1 dB RDF)
2. DX 1 only copy on the FLAG antenna HUGE DIFFERENCE
3. DX 2 much improved copy on the FLAG

Can I improve my RX with a better antenna???

SECOND STEP >> DHDL SAL or single Horizontal Flag 8.5 to 10 dB RDF↑

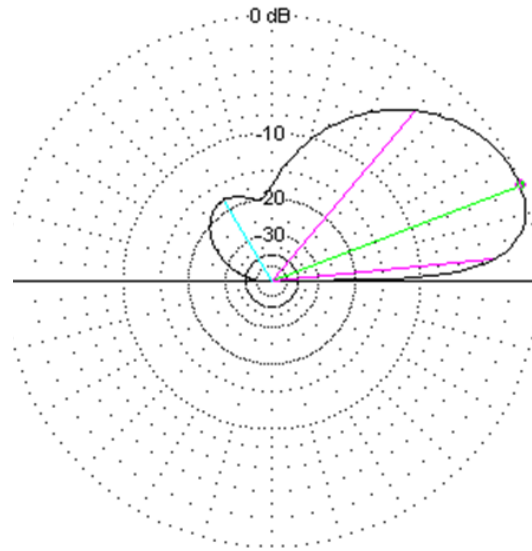
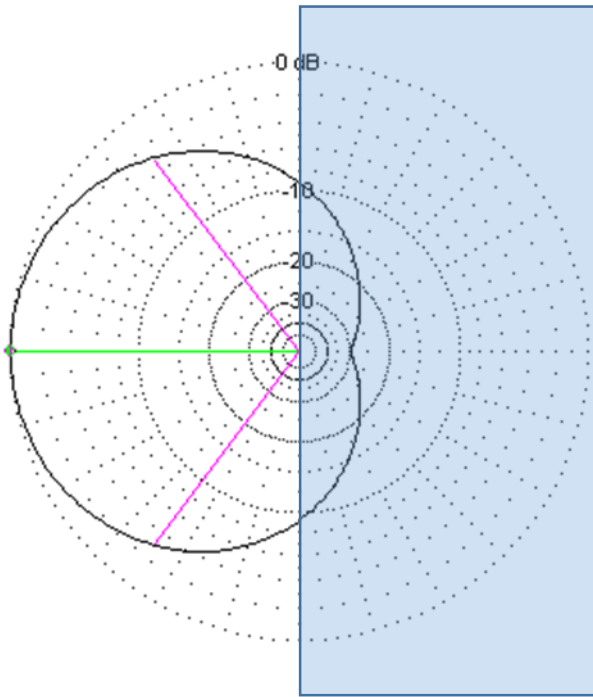

8 dB

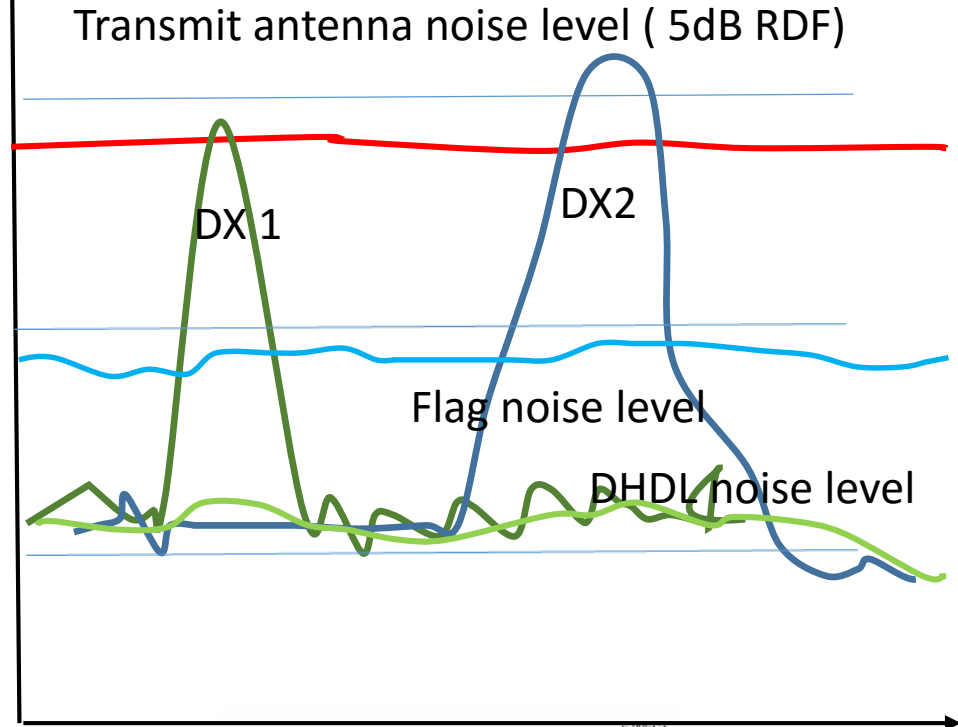

1. Vertical RDF 5 dB > FLAG RDF 9 dB (4) = 6 to 8 dB improvement

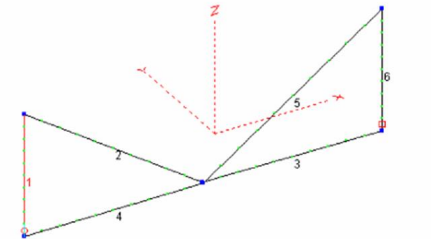

Can I improve my RX with a better antenna???

SECOND STEP >> DHDL SAL or single Horizontal Flag 8.5 to 10 dB RDF↑

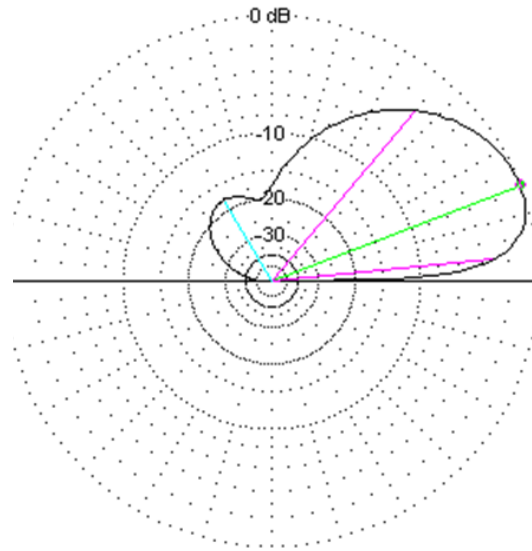
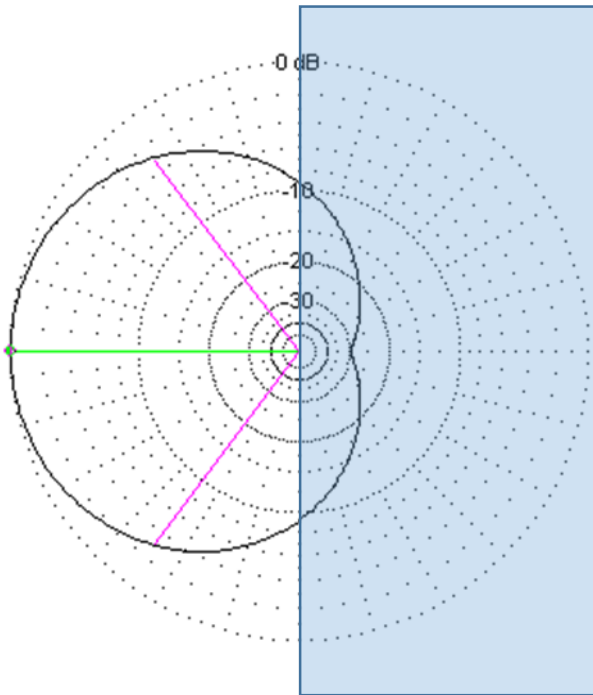

8 dB

Transmit antenna noise level (5dB RDF)

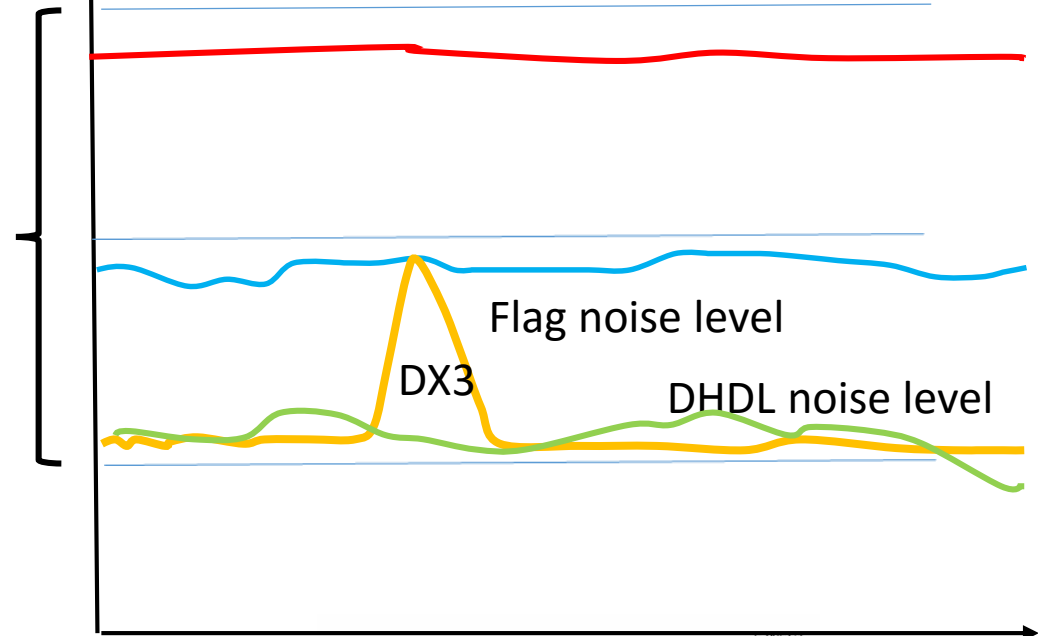

1. Vertical RDF 5 dB > FLAG RDF 9 dB (4) = 5 to 8 dB improvement
2. DX 3 only copy on the DHDL antenna MONSTER DIFFERENCE
3. DX 3 at noise level on the FLAG
4. Vertical useless for RX FRUSTRATION !!!

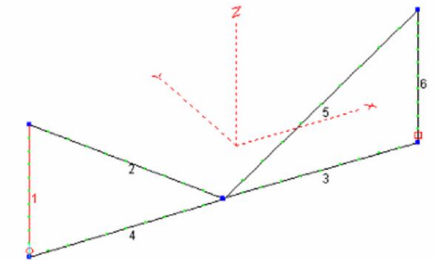

Can I improve my RX EVEN better antenna???

THIRD STEP >> RX 4 square Waller Flag 1000Ft beverage 11.5 dB RDF↑

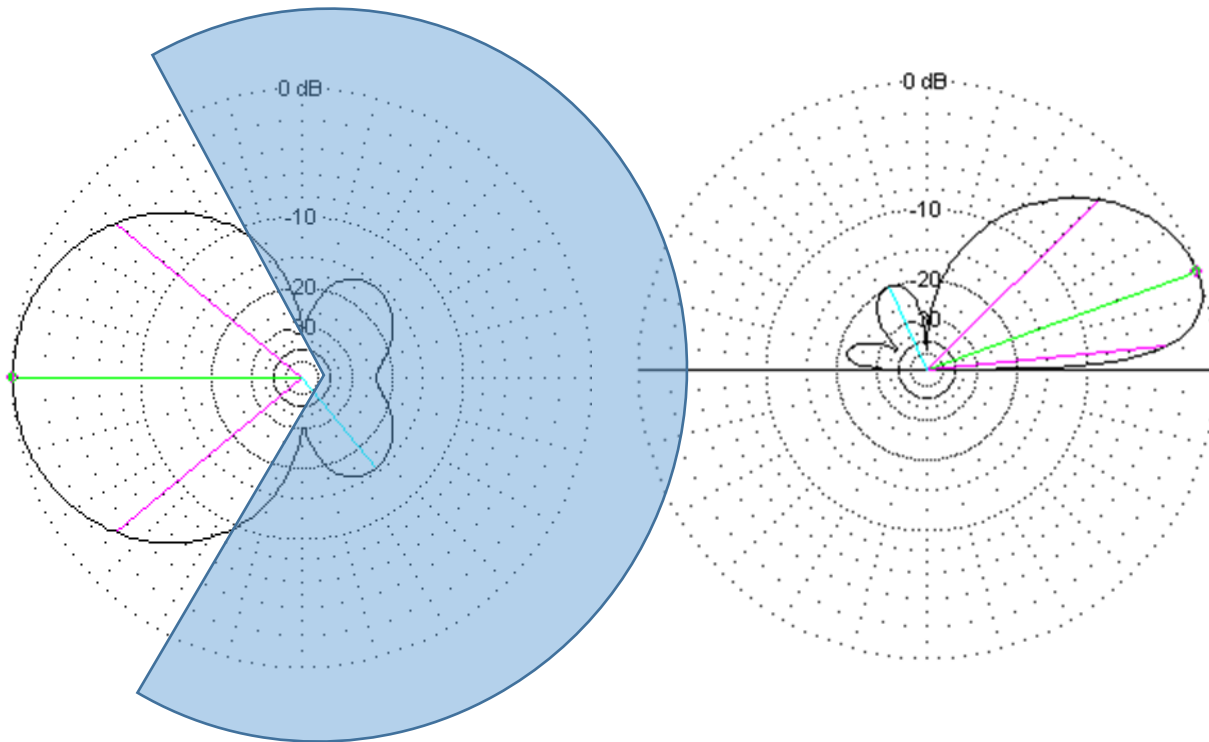

8 dB

Transmit antenna noise level (5dB RDF)

Flag noise level

DX3

DHDL noise level

1. Vertical RDF 5 dB > WF 11.5 dB (6.5) = 9.7 to 13 dB improvement

Can I improve my RX EVEN better antenna???

THIRD STEP >> RX 4 sq WF 1000Ft beverage 11.5 dB RDF

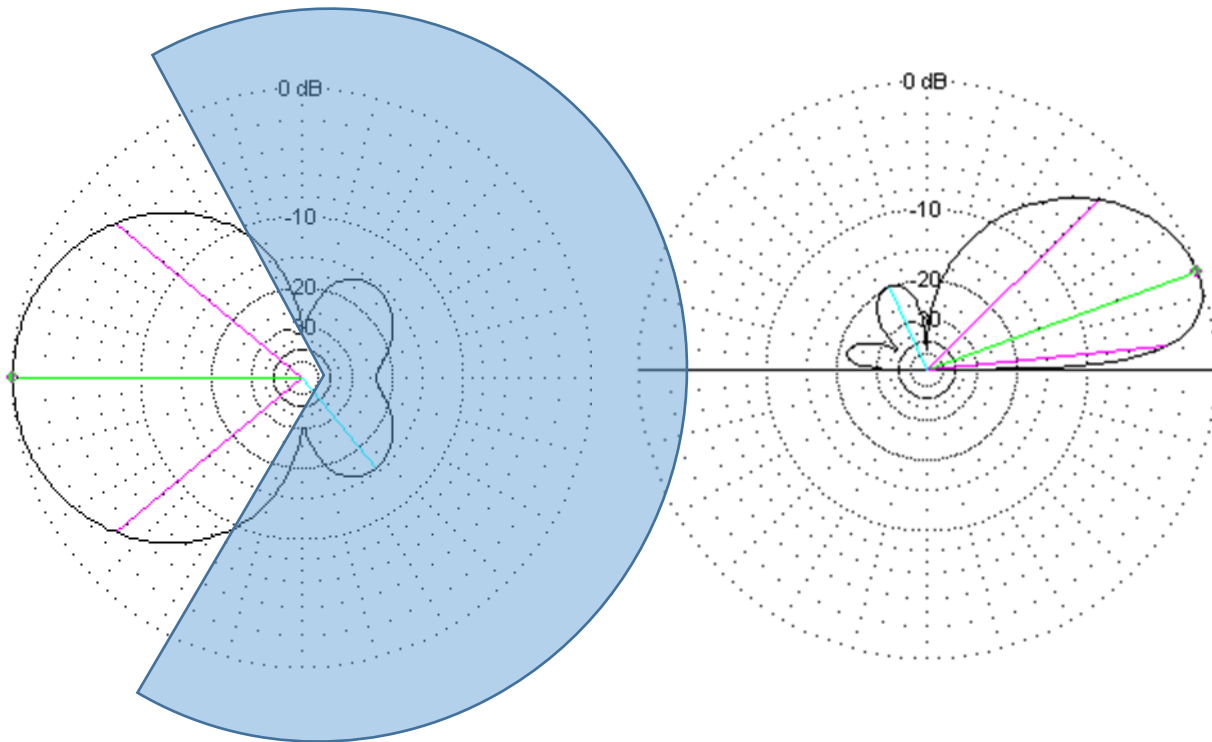

13 dB

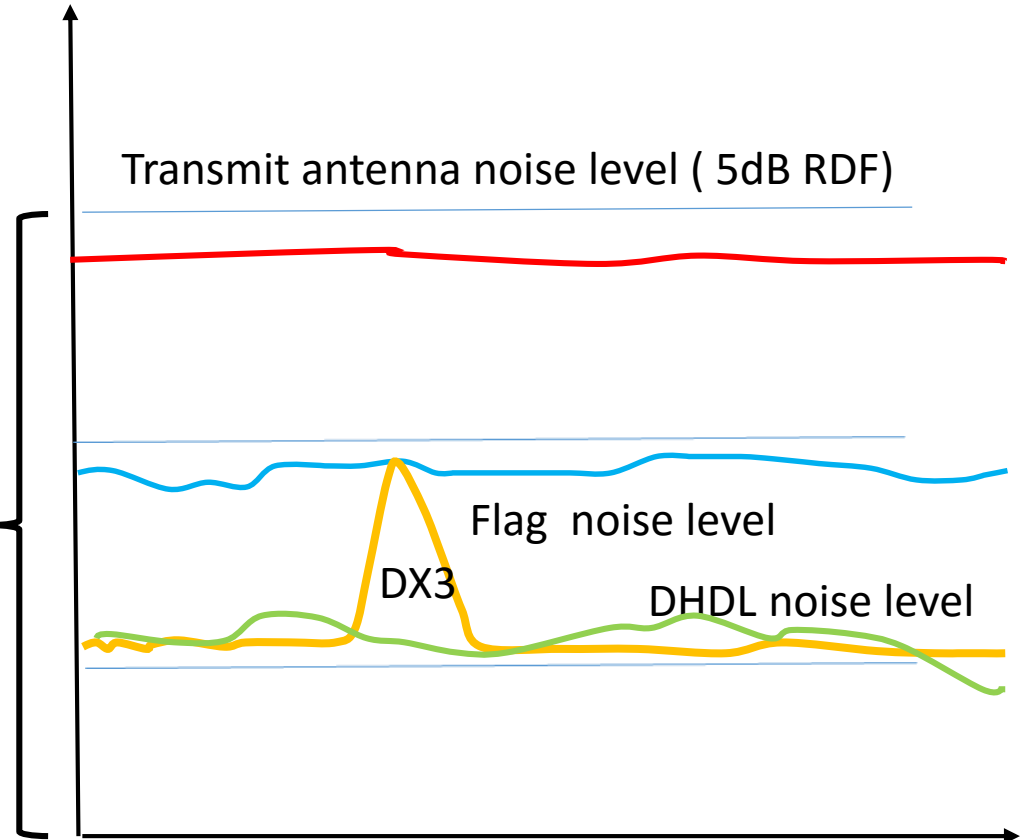

1. Vertical RDF 5 dB > WF 11.5 dB (6.5) = 9.7 to 13 dB improvement

Can I improve my RX EVEN better antenna???

THIRD STEP >> RX 4 sq WF 1000Ft beverage 11.5 dB RDF

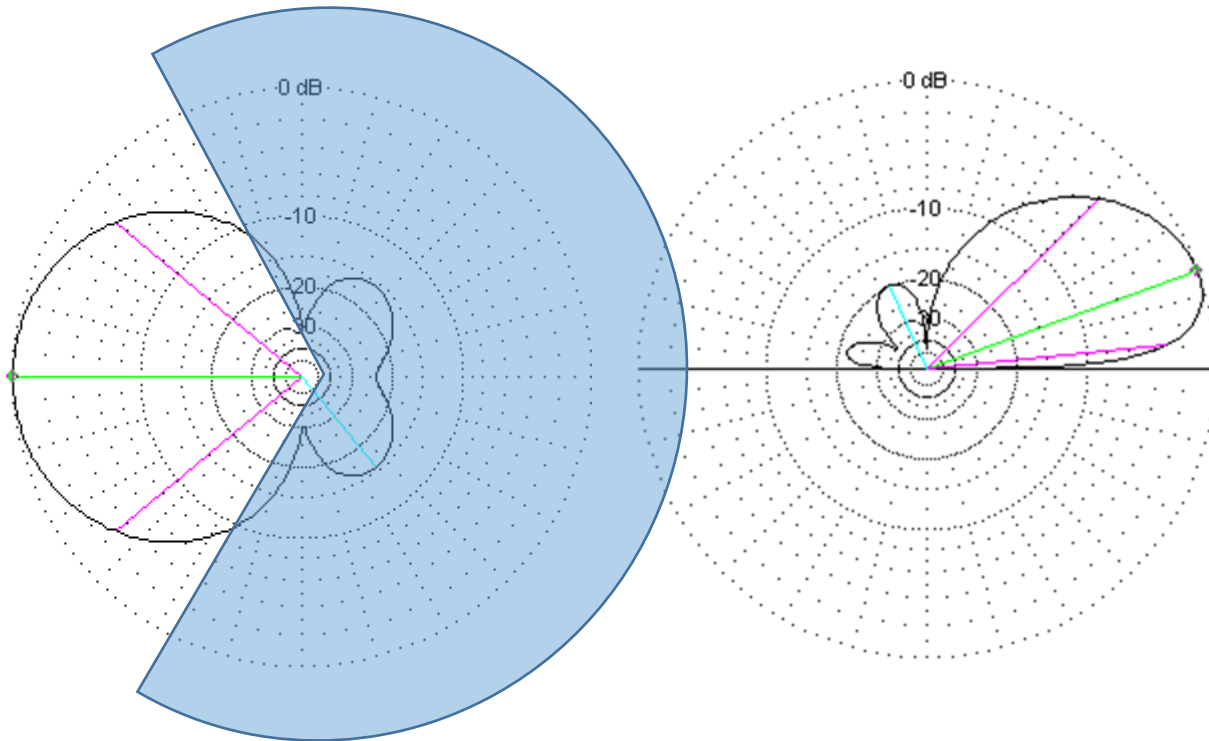

1. Vertical RDF 5 dB > WF 11.5 dB (6) = 9 to 12 dB improvement
2. DX 3 very comfortable copy on the WF
3. DX 4 below noise level on the FLAG and the DHDL
4. WF copy DX4 UNBELIEVABLE !!!!

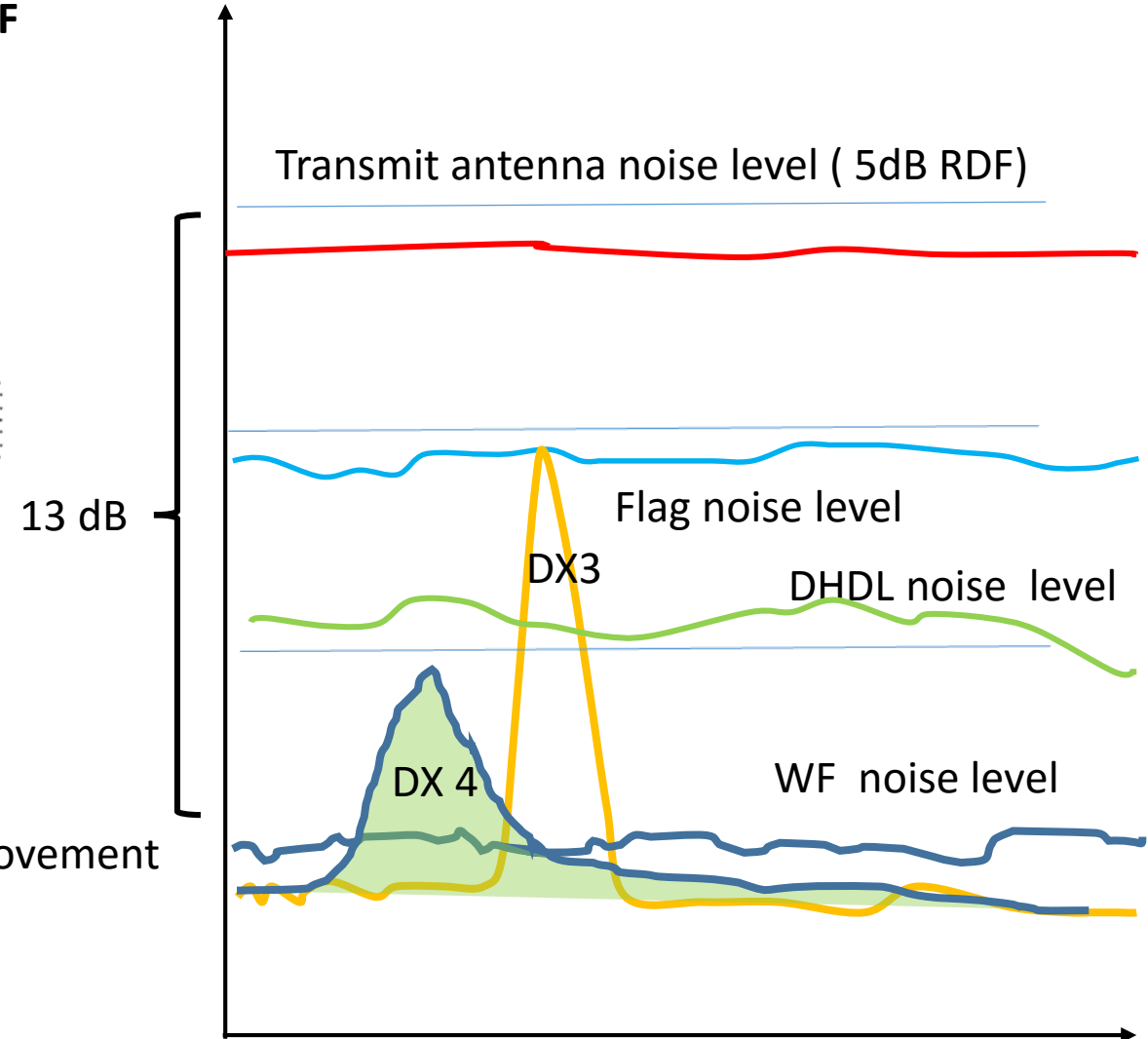

Can I improve my RX EVEN better antenna???

THIRD STEP >> Rotating the WF

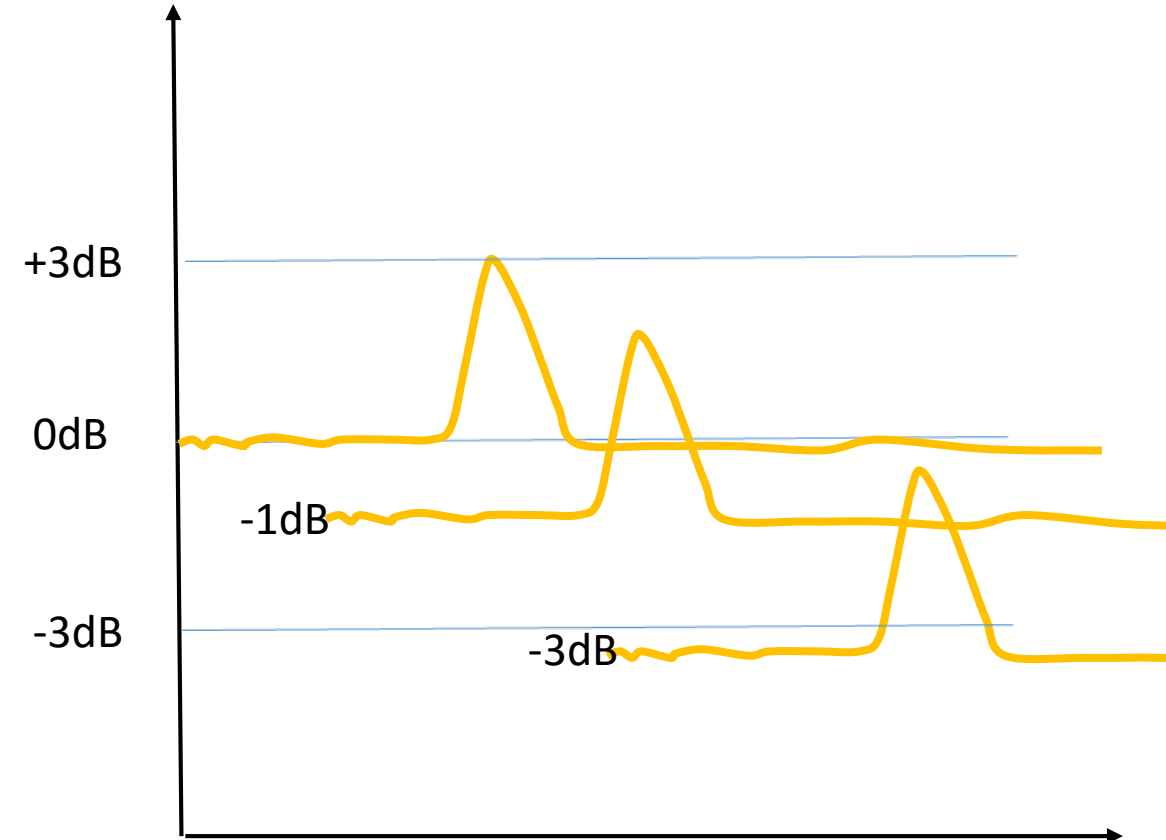
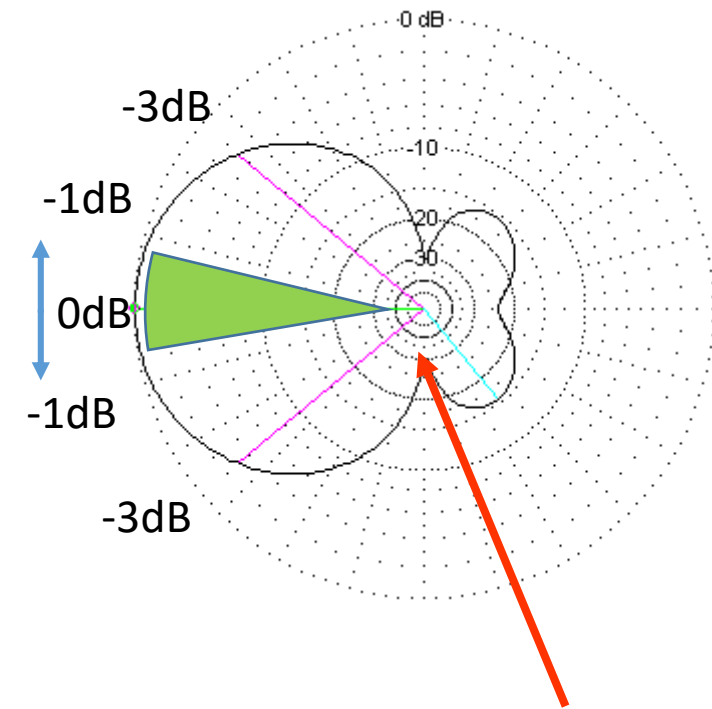

1. Rotating the antenna we always can aim to maximum gain or 0 dB attenuation
2. Moving the antenna from that point the reduce the SNR
3. Moving half the aperture to -3 dB point the signal goes to noise level and hard to copy
4. Moving the 10 to 20 degree each side can get a noise source at the side null and increase the SN even more

Polarization filter, the HWF, Horizontal Waller Flag

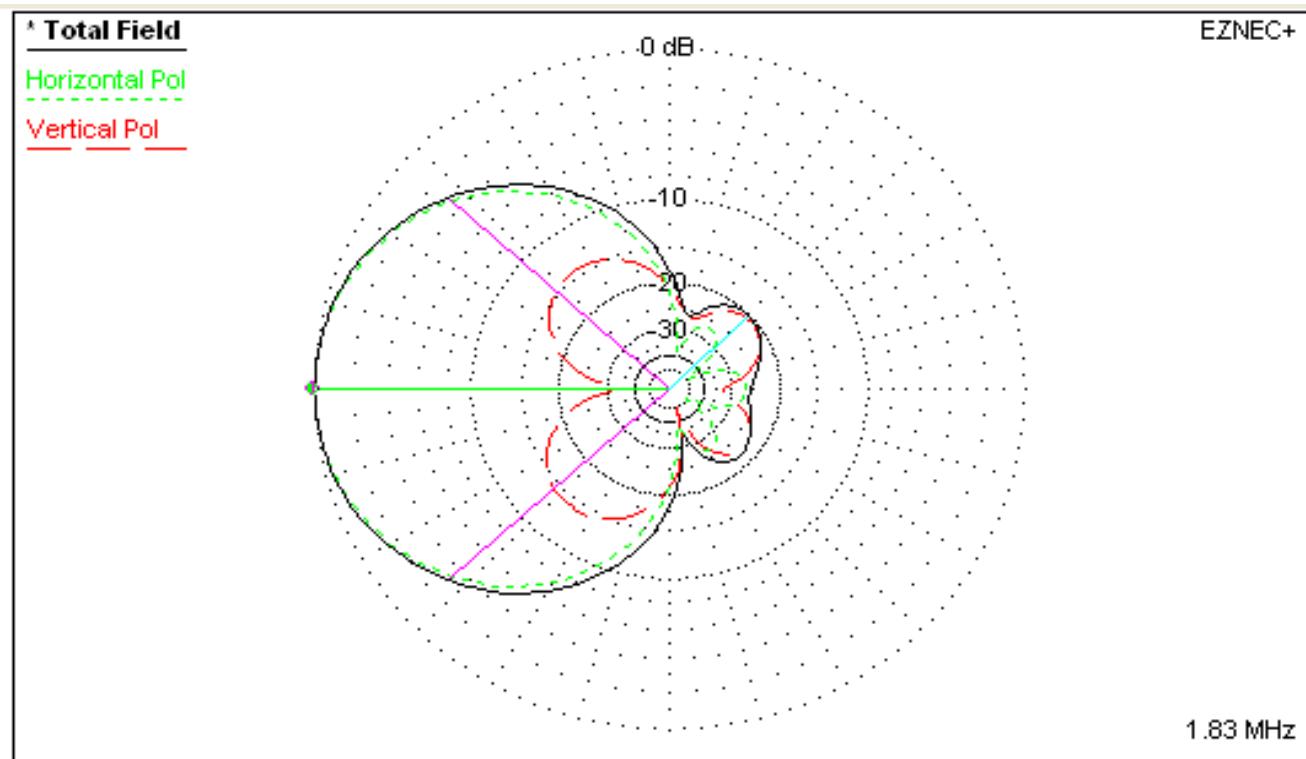

Azimuth Plot		Cursor Az	180.0 deg.
Elevation Angle	38.0 deg.	Gain	-50.47 dBi
Outer Ring	-50.47 dBi		0.0 dBmax
			0.0 dBmax3D
3D Max Gain	-50.47 dBi		
Slice Max Gain	-50.47 dBi @ Az Angle = 180.0 deg.		
Front/Back	25.31 dB		
Beamwidth	84.1 deg.; -3dB @ 138.0, 222.1 deg.		
Sidelobe Gain	-70.61 dBi @ Az Angle = 44.0 deg.		
Front/Sidelobe	20.14 dB		

**MAN MADE
NOISE
REJECTION**

BUT !!! WHAT ABOUT MY LOCAL CITY NOISE!

FORTH STEP >> Polarization filter HWF 11.5 to 12 dB RDF

* Total Field

Horizontal Pol

Vertical Pol

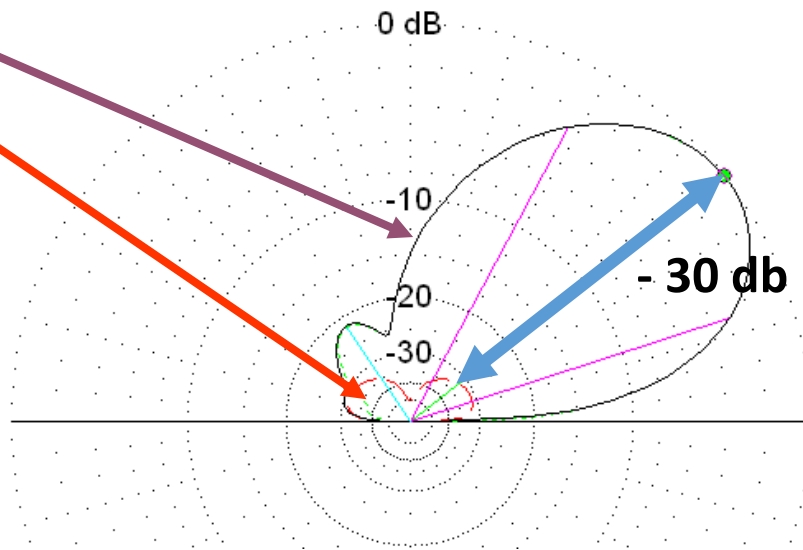

1. The HWF attenuate vertical polarized signal > -30 dB
2. Removing local ground wave noise the HWF noise floor is 10 dB better
3. DX 4 very comfortable copy on the HWF
4. HWF copy DX4 for long time with much better SNR
5. HWF can hear DX 5
6. HWF can hear what others can't , and anywhere
7. DIGITAL Modes JT9 or JT65 can experience 18 dB more in SNR (30 dB)

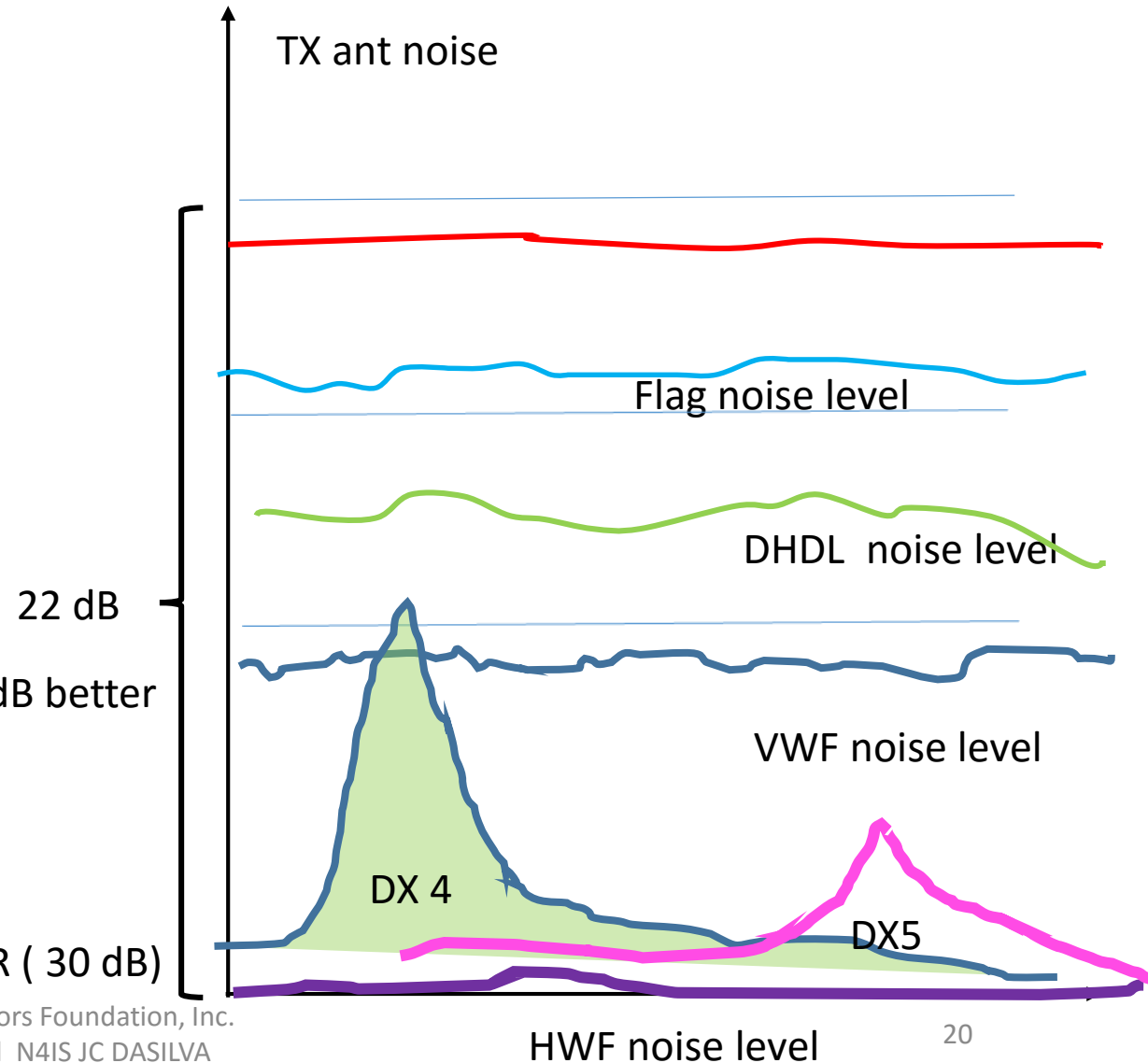

Harold Beverage patents 1938 1941 (80 years ago)

- US 2138134 A Phasing antennas
- US 2247743 A Broad Band RX Antenna
- **ABSTRACT** > [available in](#)

Waller Flag is a Beverage antenna

July 1, 1941. H. H. BEVERAGE 2,247,743

ANTENNA
Filed Dec. 10, 1938

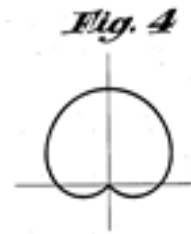
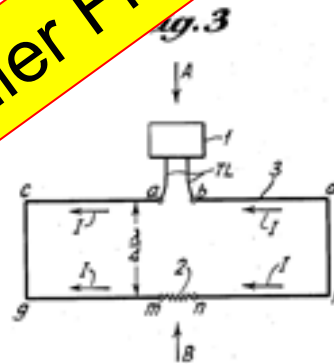
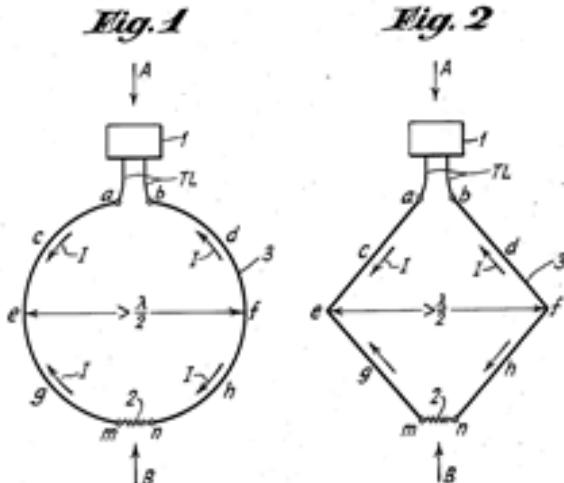

INVENTOR HAROLD H. B. BY W.S. Brown ATTORNEY

LOADED LOOP = WIRE + TRANSFORMER + RESISTOR

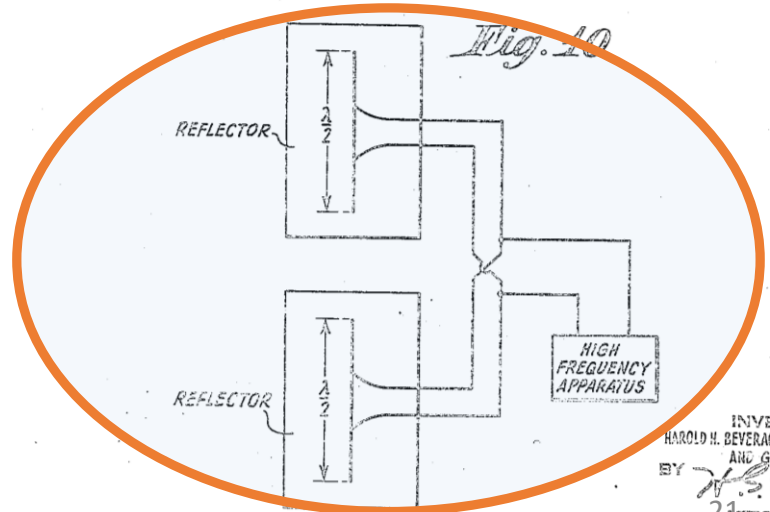
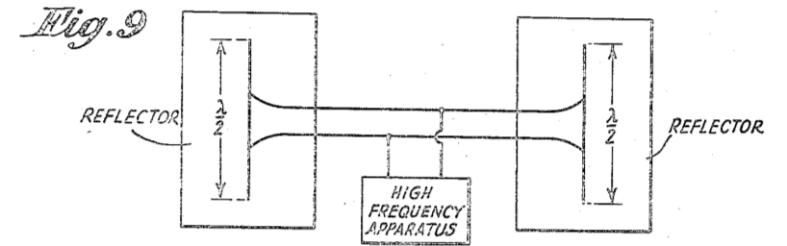
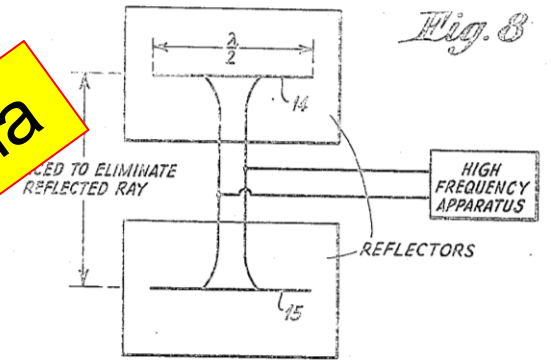

INVENTORS HAROLD H. BEVERAGE, PHILIP S. CARTER AND GILBERT S. WICKIZER BY W.S. Brown ATTORNEY

N4IS Horizontal Waller Flag HWF

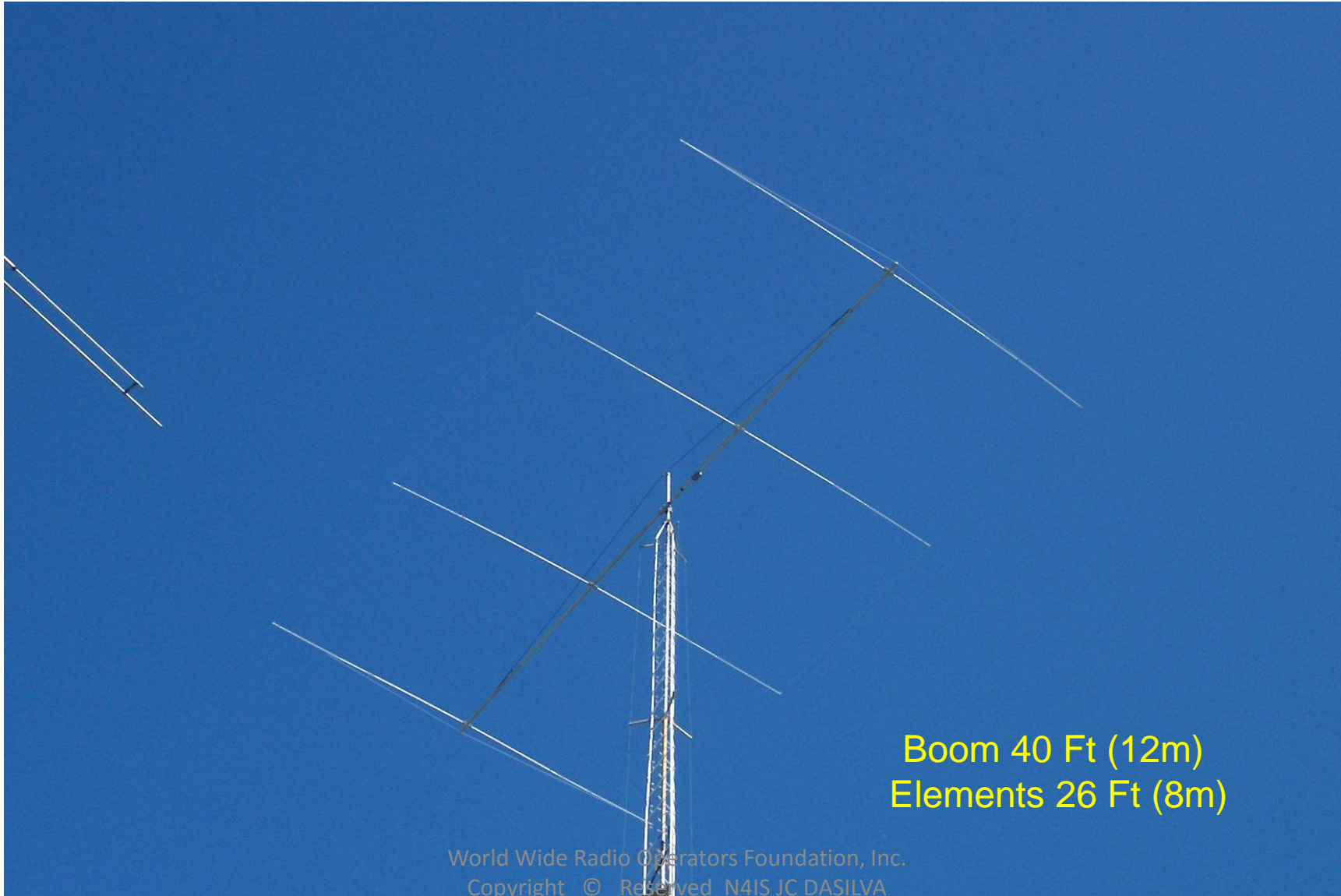

3/4/2016

World Wide Radio Operators Foundation, Inc.
Copyright © Reserved N4IS JC DASILVA

N4IS Horizontal Waller Flag HWF

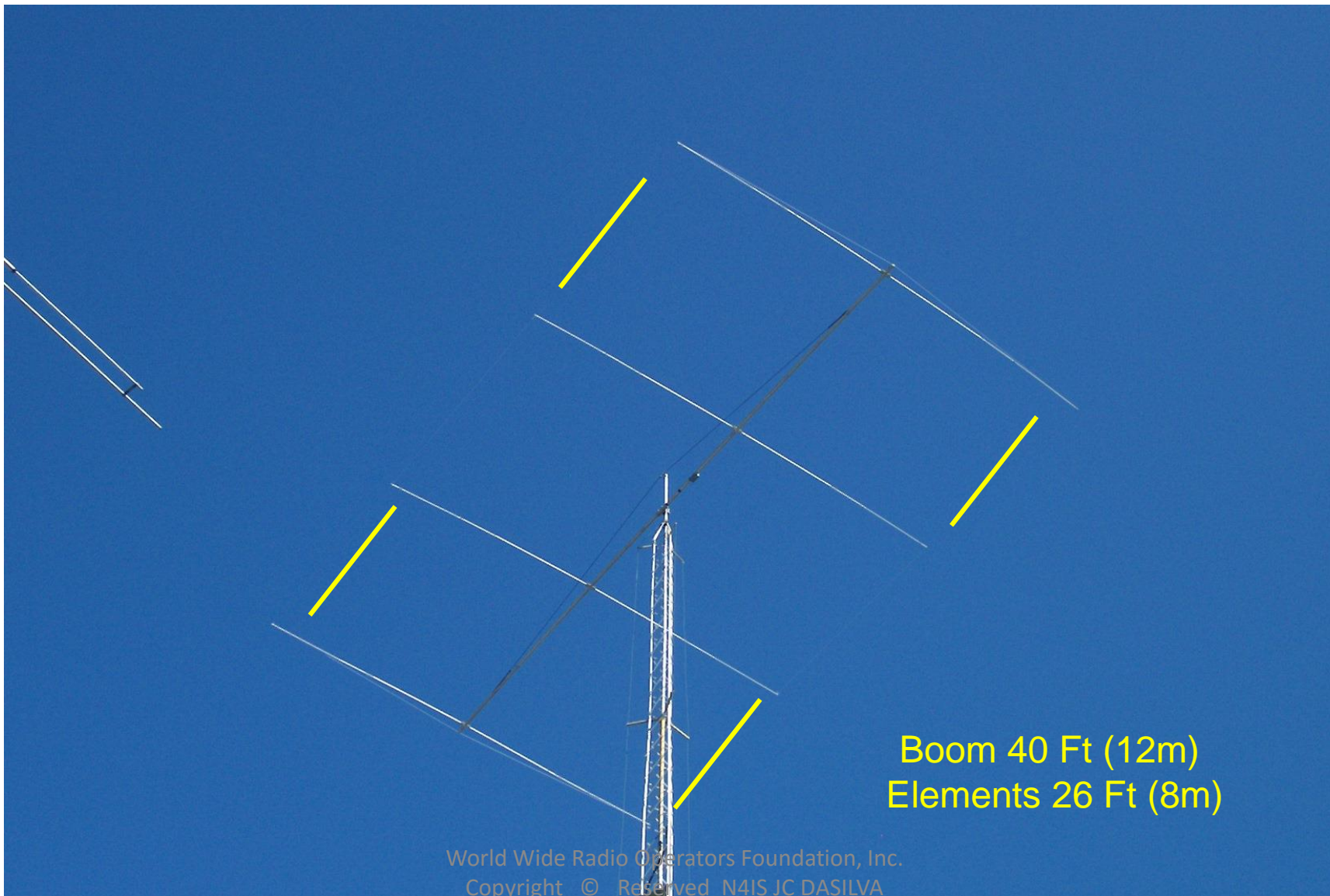

2006 VWF

2009 HWF

299 DXCC heard

282 DXCC worked

39 zones

**30 ATNO
Average per
year on 160m**

Boom 40 Ft (12m)
Elements 26 Ft (8m)

HWF, Horizontal Waller Flag Polarplot 40m

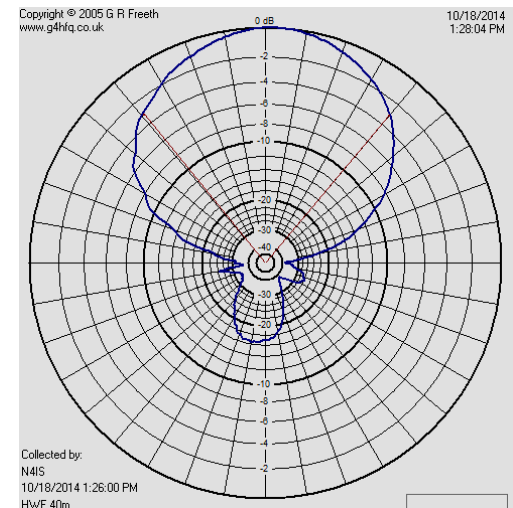
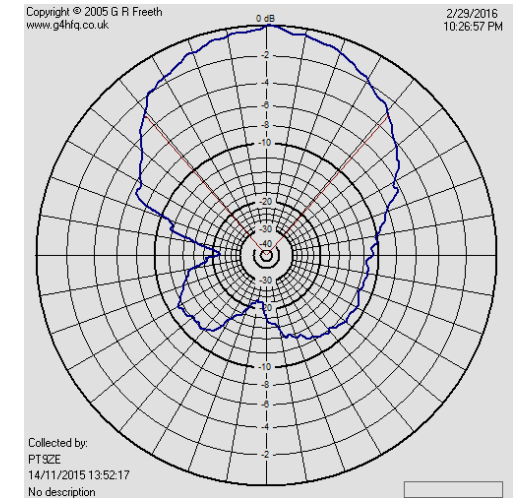
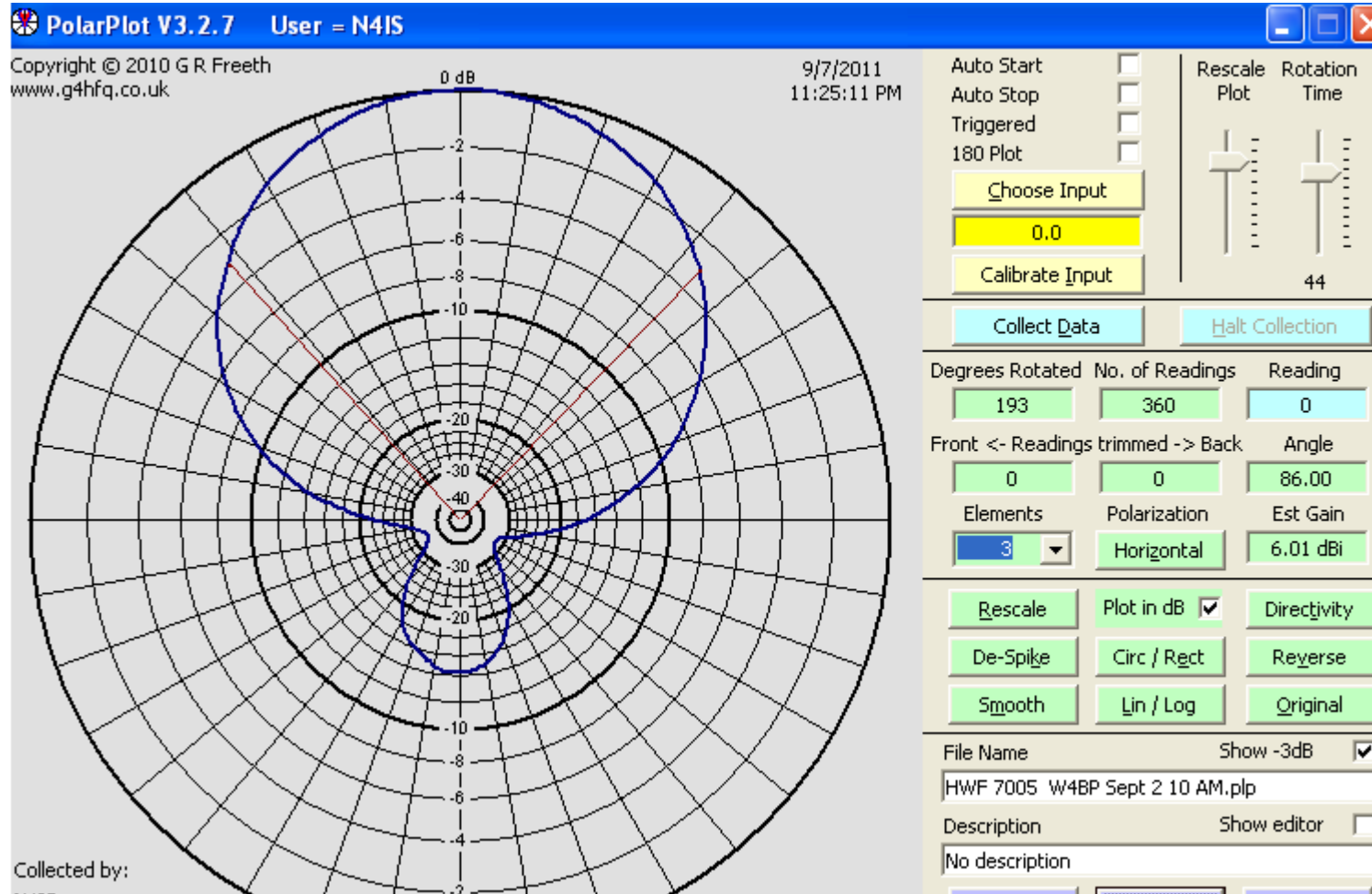

HWF, Horizontal Waller Flag Polarplot 80m / 160m

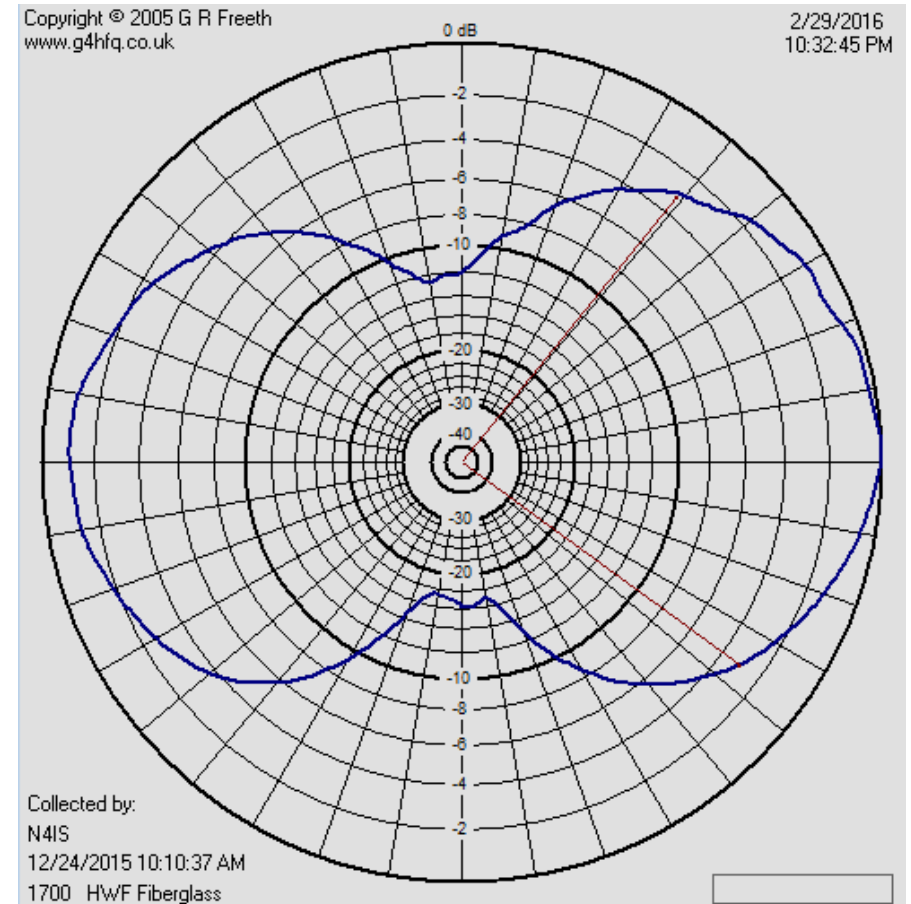
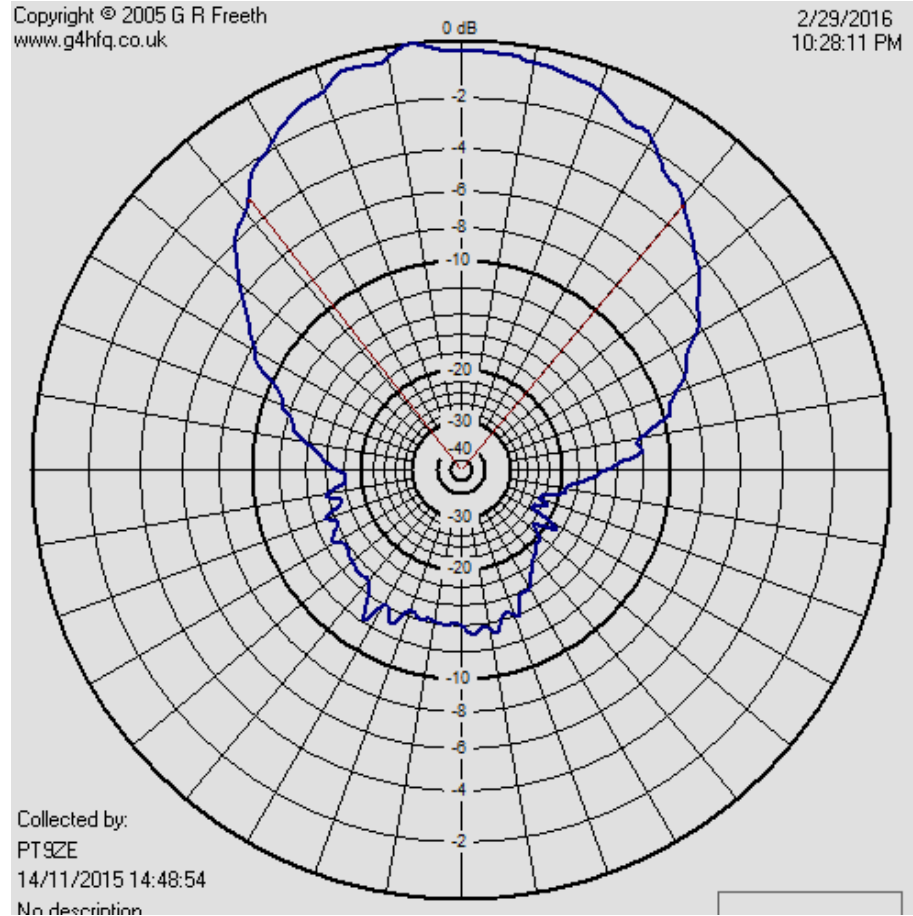

WHAT is a Horizontal Waller Flag?

* Total Field

Horizontal Pol

Vertical Pol

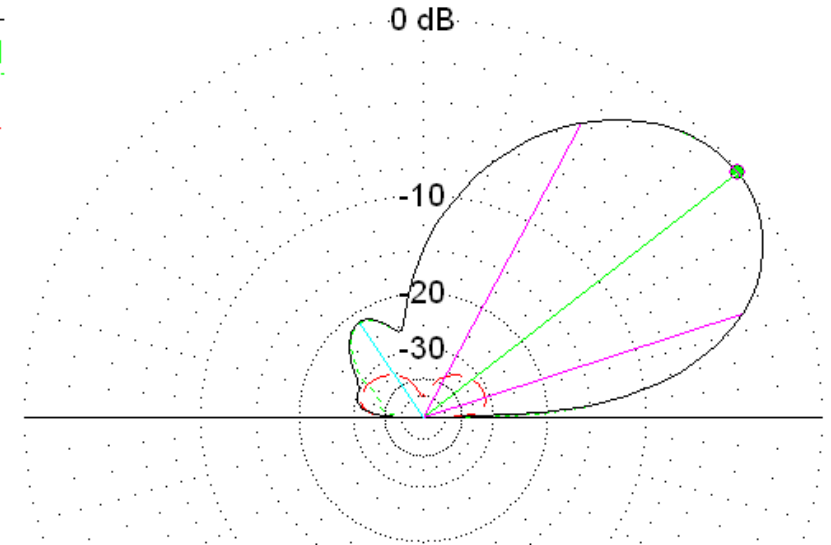
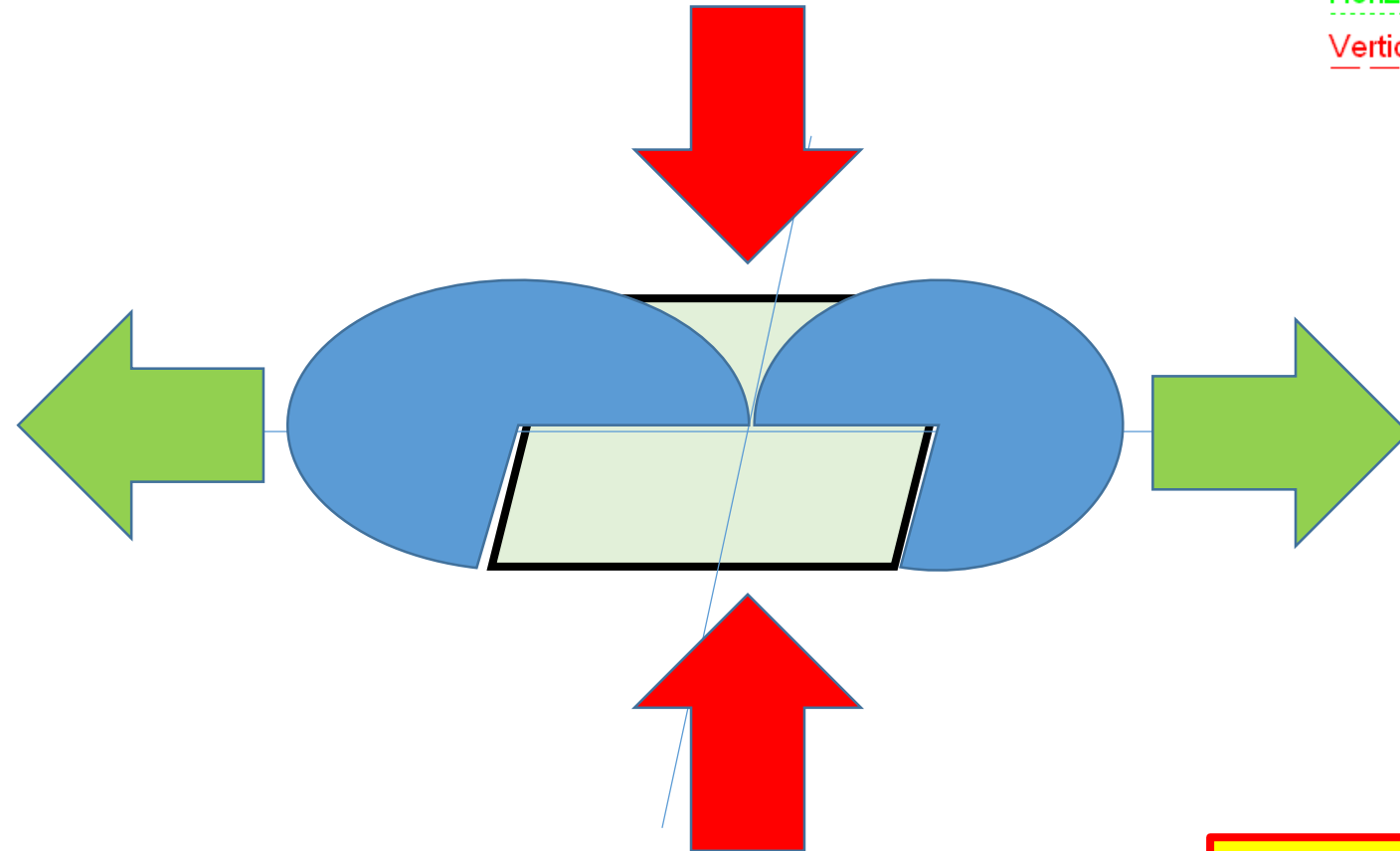

TAKE OFF ANGLE DOES NOT CHANGE
WITH HEIGHT ABOVE GROUND

RDF DOES NOT CHANGE WITH SIZE

RDF DOES NOT CHANGE WITH FREQUENCY

NOT RESONANT

NO INTERACTION WITH OTHER ANTENNAS

VERTICAL ISOLATION 27 dB

HWF Gain change with height above ground

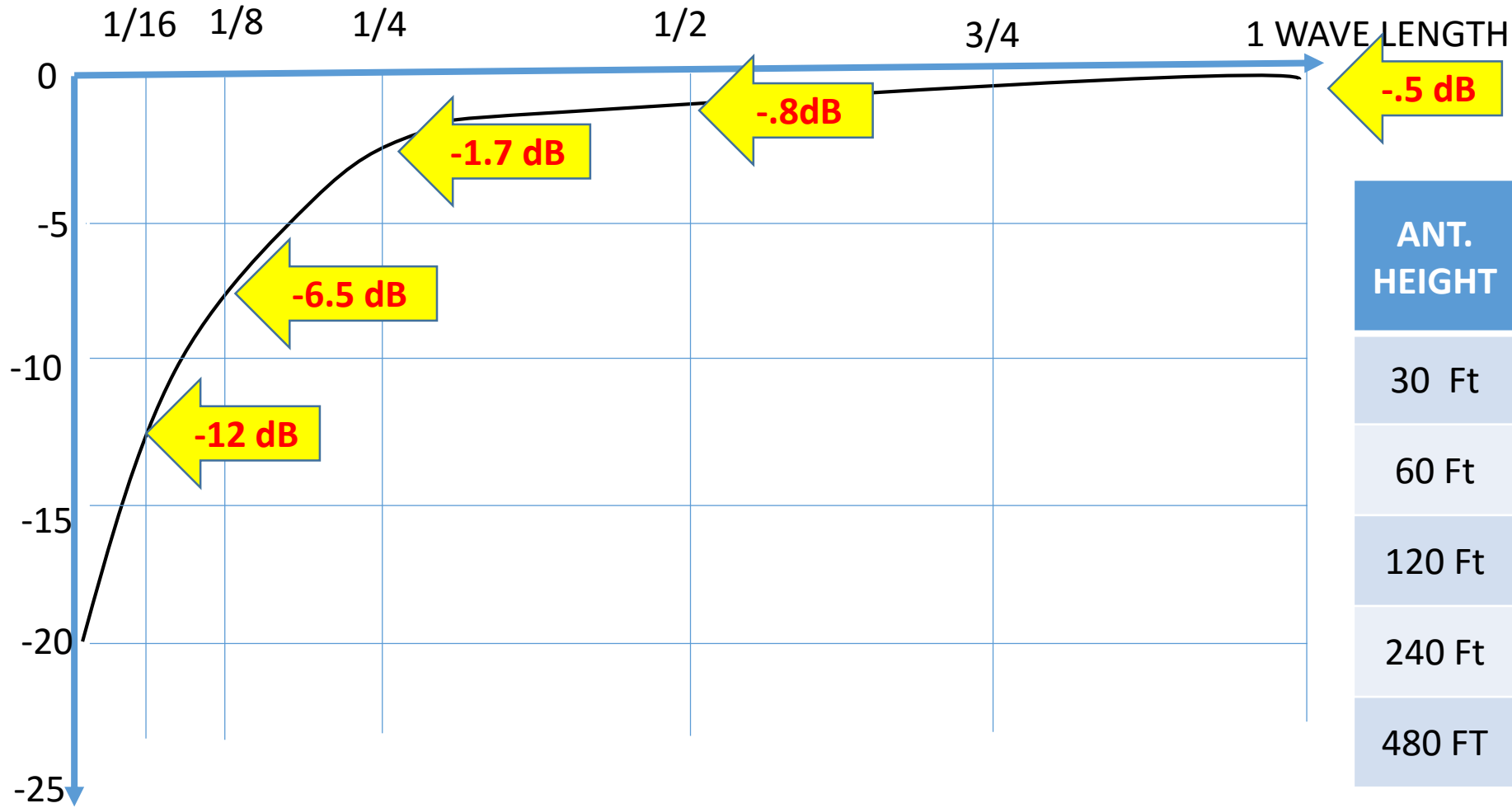

ANT. HEIGHT	7 MHz	3.5 MHz	1.8 MHz
30 Ft	1/4	1/8	1/16
60 Ft	1/2	1/4	1/8
120 Ft	1	1/2	1/4
240 Ft	2	1	1/2
480 FT	4	2	1

Horizontal signal intensity changes with height above ground

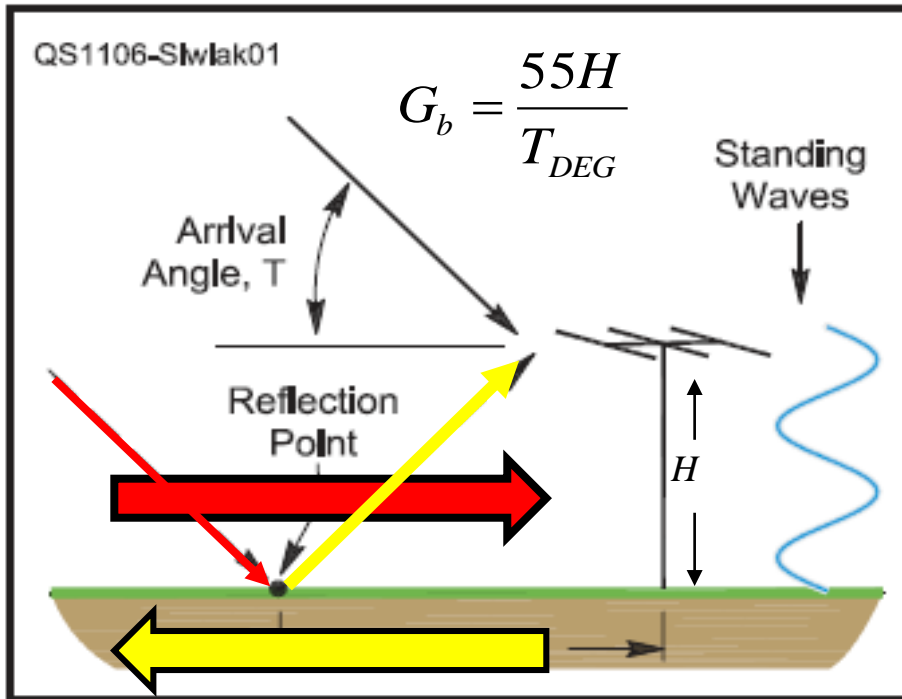

Figure 1 — Waves arrive directly and via an earth reflection forming a local vertical standing wave pattern.

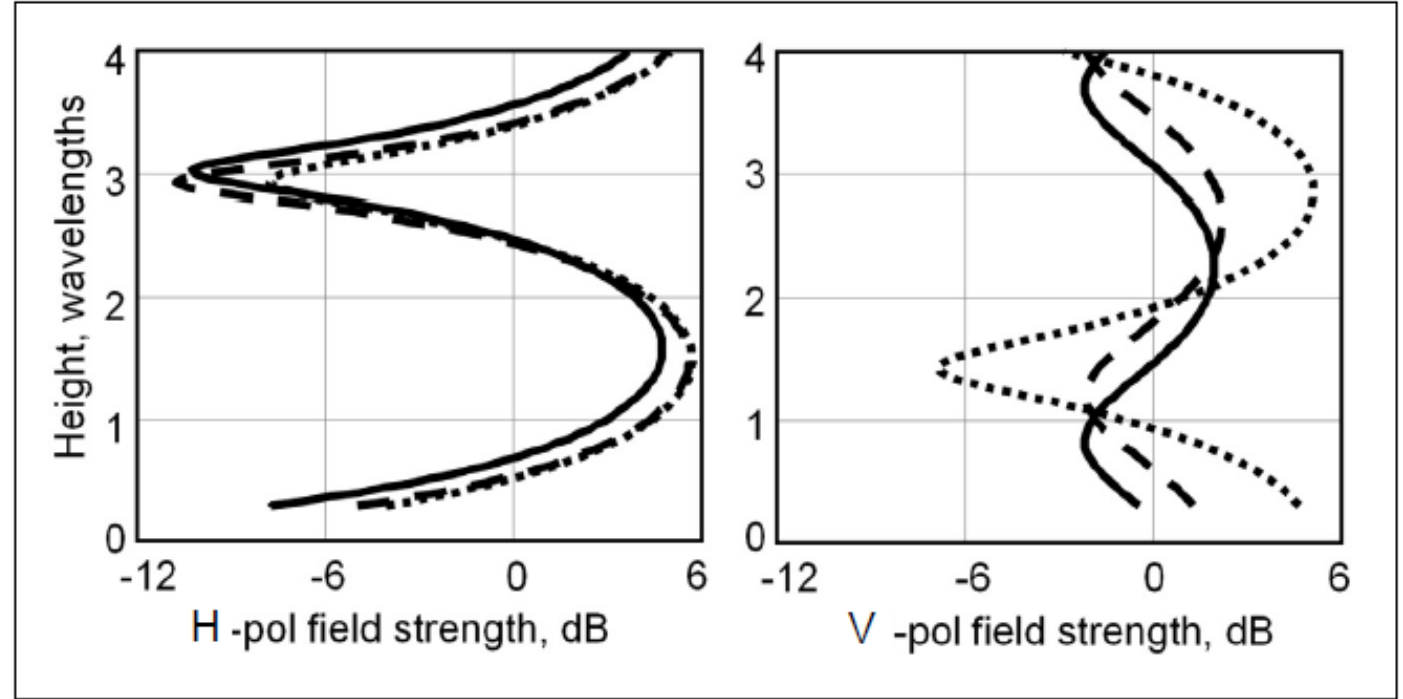
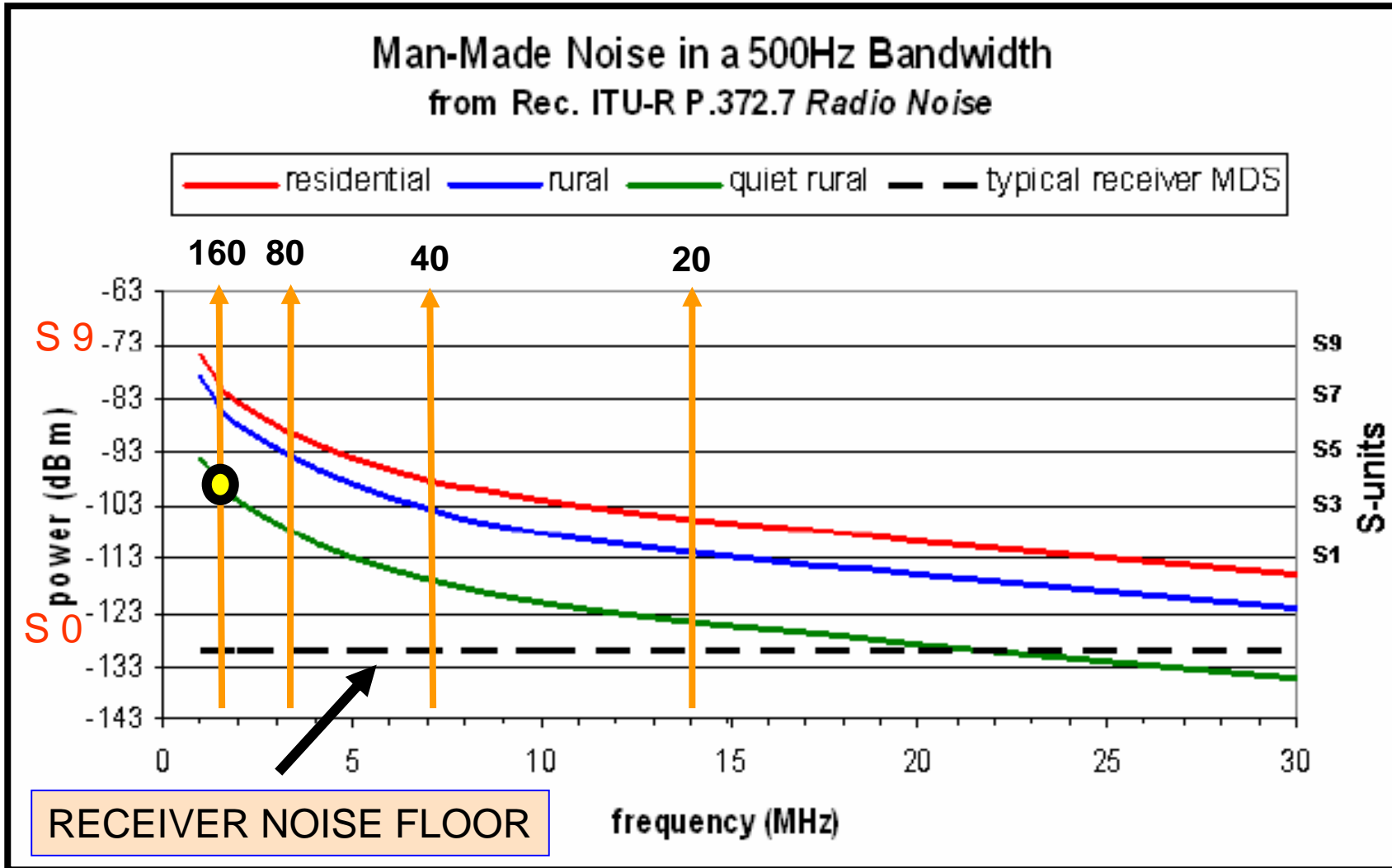

Figure 2—The vertically polarized (V-pol) and horizontally polarized (H-pol) field strengths vary differently and depend on whether the reflection is from medium earth ground (solid), fresh water (dashed) or sea water (dotted).

Fig.1— K. Siwiak, KE4PT, “Is There an Optimum Height for an HF Antenna?” Jun 2011, QST, pp 33– 35.

Fig.2— K. Siwiak, “Ionospherica – The Last Bounce”, QRP Quarterly, Fall 2013, pp 32-33.

Man-Made Noise in a 500Hz Bandwidth



**Man-Made noise
vertical polarized
ground wave**

dBm above receiver noise floor
in a 500Hz Bandwidth

160 m	47 dBm	42	30
80 m	35 dBm	30	22
40 m	20 dBm	15	10

Power line noise at home

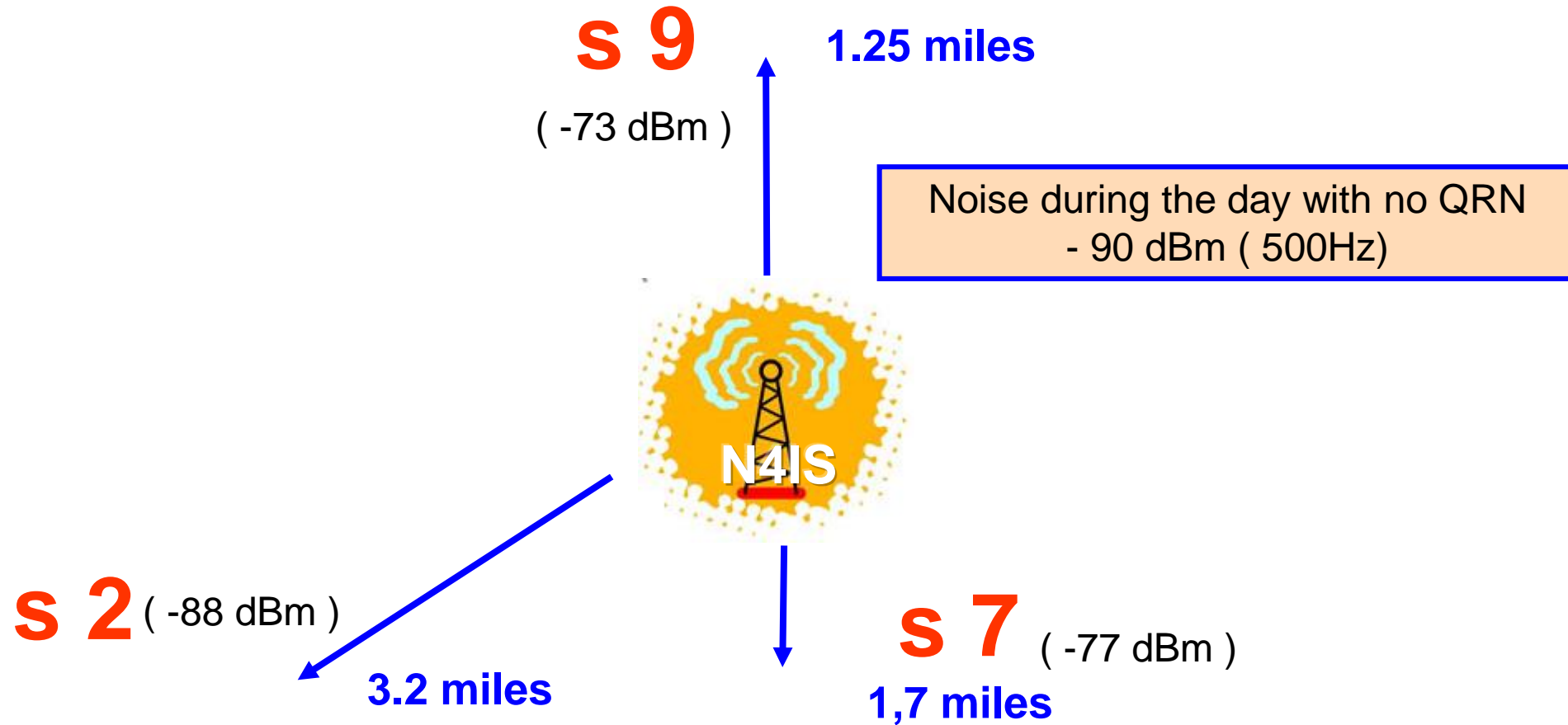

Antenna noise temperature in Kelvin

Noise temperatures at medium and high frequencies Fig 11-44 pg. 414 Edward C. Jordan and Keith G. Balmain -RECOMMENDATION ITU-R P.372-7 - Radio noise*

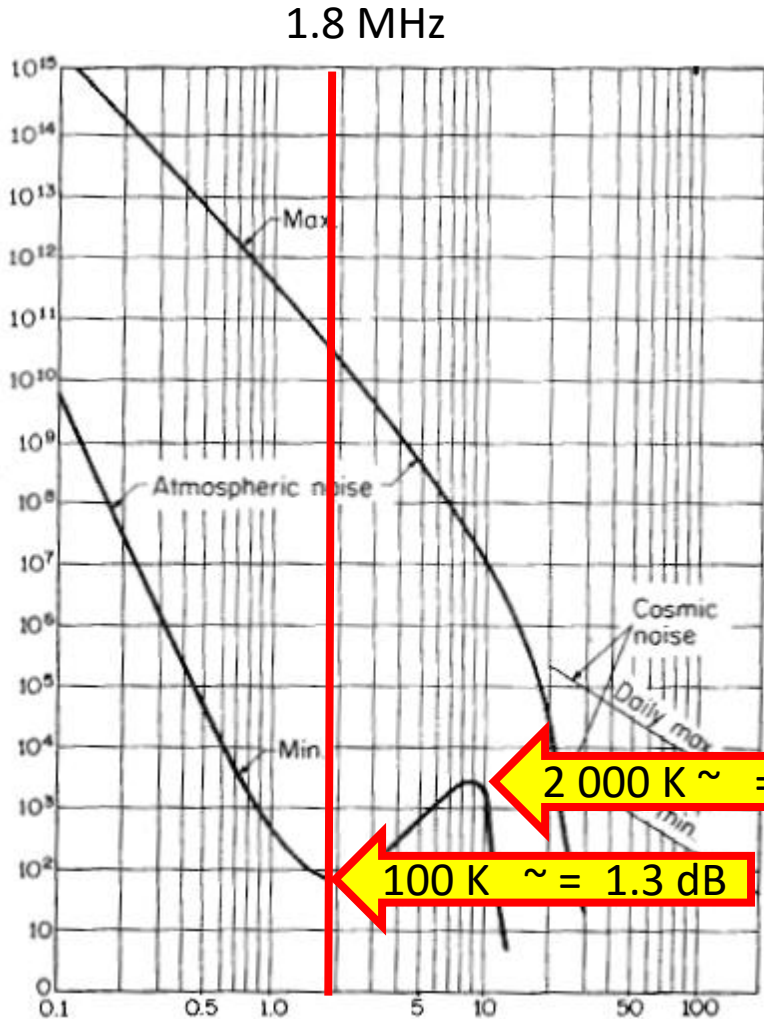

Sky wave propagation noise

- Minimum noise during a quiet winter morning can be as low as 1.3 dB
- System Noise Figure of 1.3 dB degrades the signal to noise ratio by 3 dB
- The insertion loss of all passive devices adds directly to Noise Figure
- N4IS RX system has 1.4 dB NF >>
 - IC7800 20 dB NF
 - N4IS .5 dB preamplifier (40 dB gain)
 - Input Filter .2 dB

WF system operates near the receiver noise floor

Shielding, grounding, isolation and common mode noise reduction is critical

Noise layers and low band DX signals

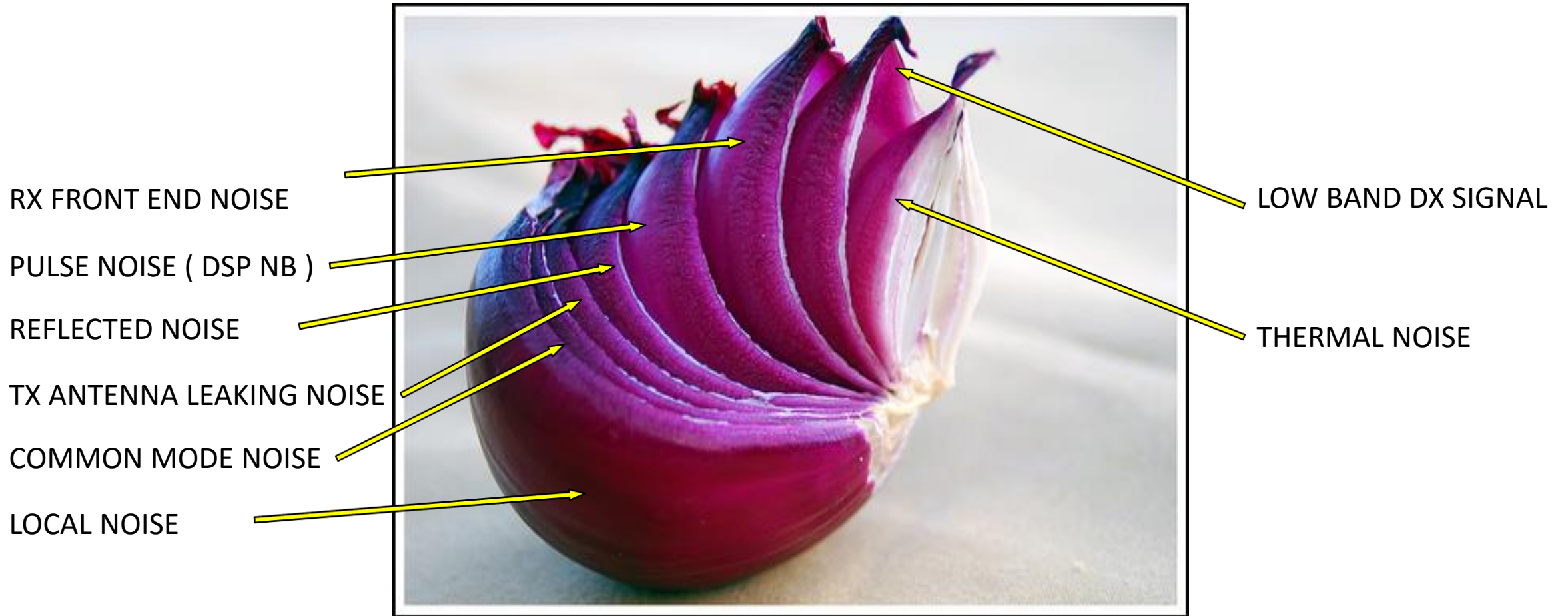

DETUNING TX antenna is a “MUST DO” !

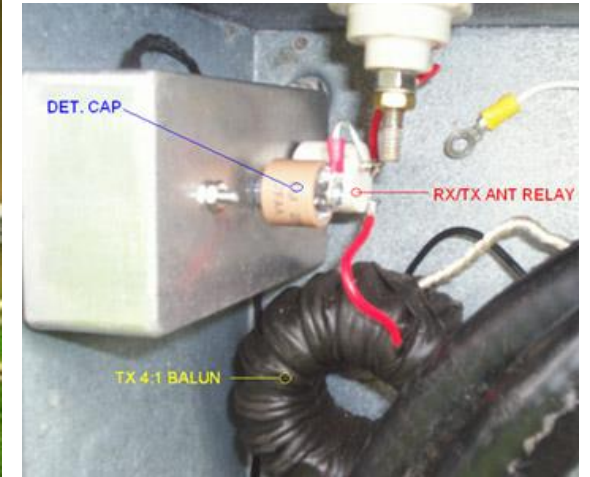
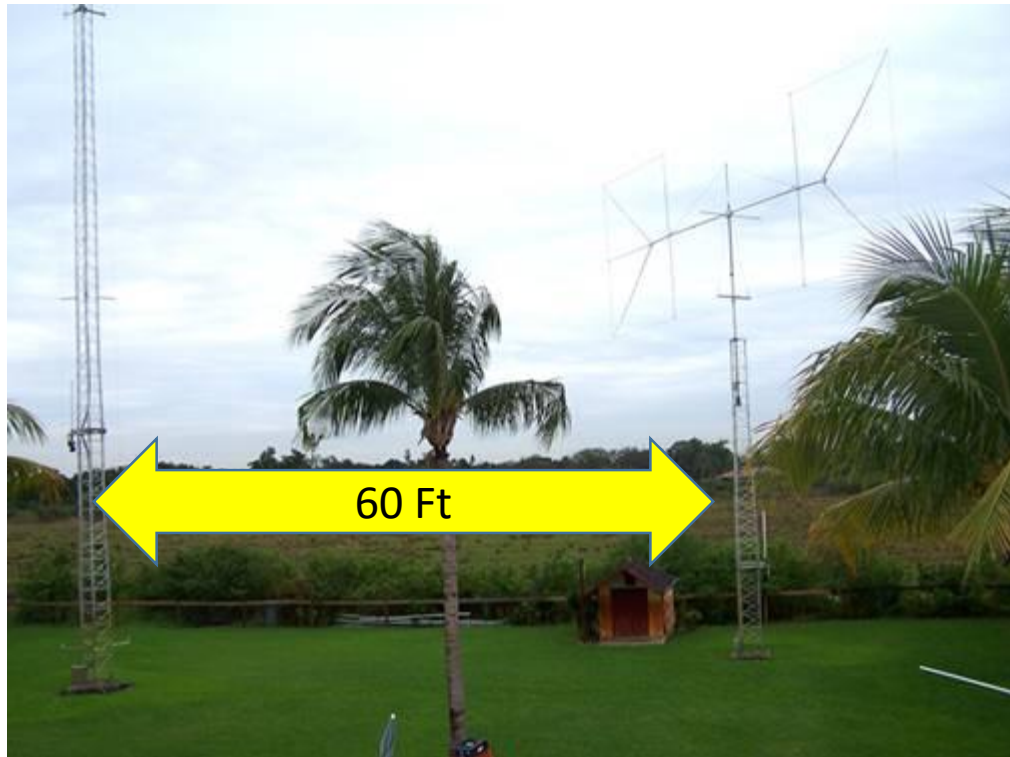

Detuning a resonant structure is a critical factor to success. Removing the detuning effect of the skirt by a short circuit to ground has a drastic impact on the plot diagram.

DETUNING TX antenna is a “MUST DO” !

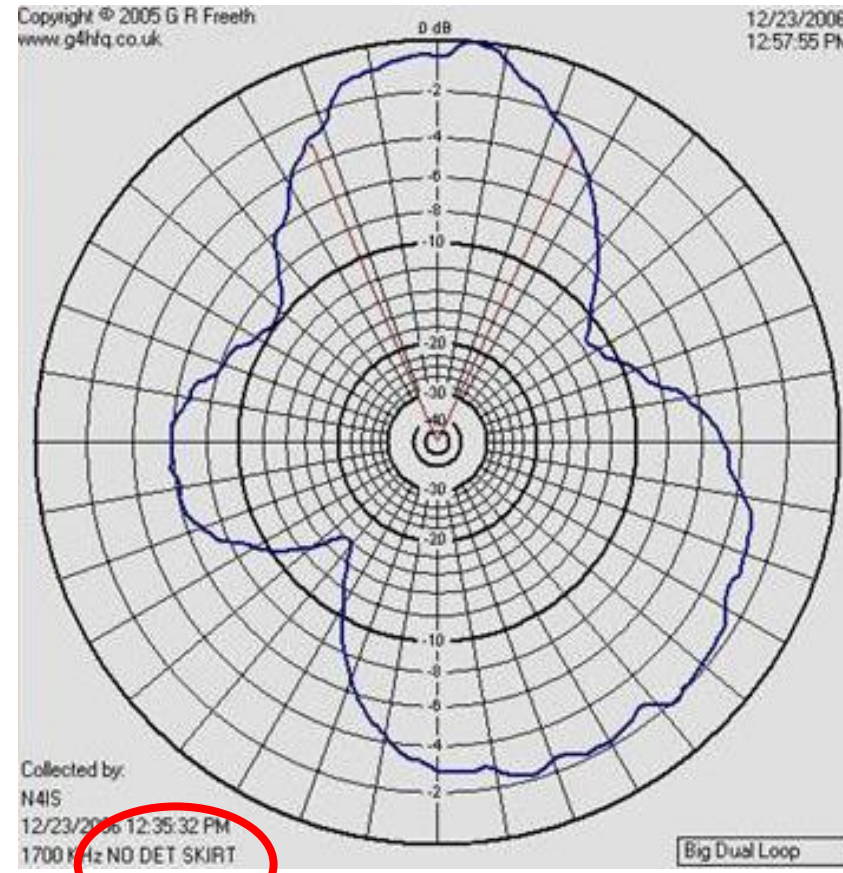
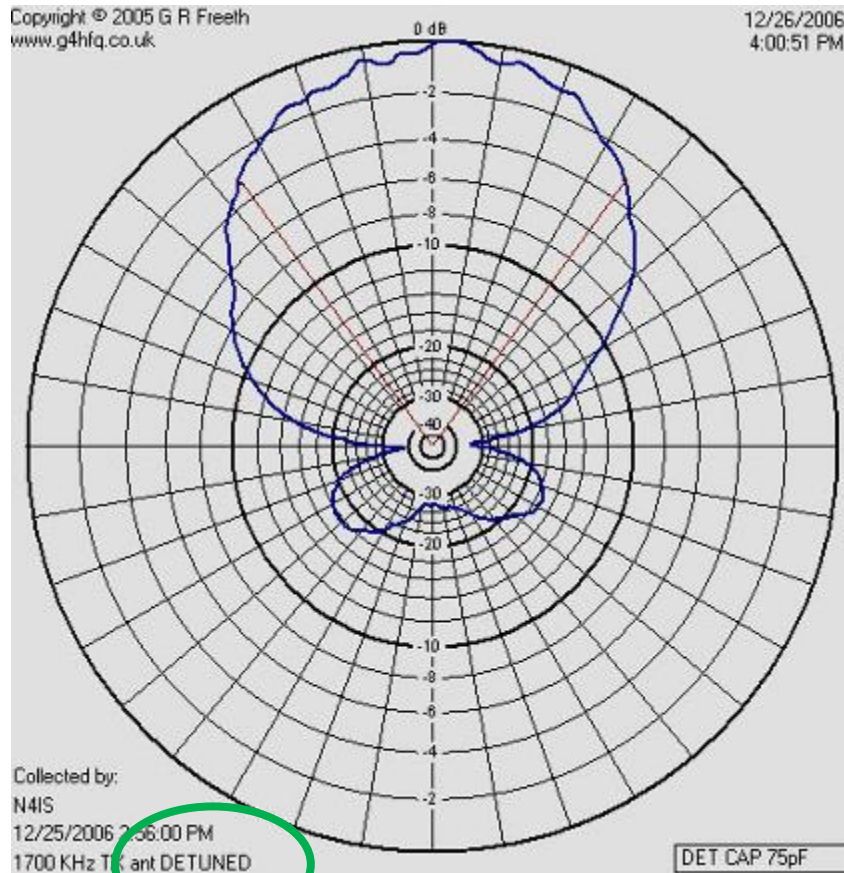

Detune TX antennas, nearby structures, elevated radials and low dipoles, that degrade radiation pattern.

INTERACTION BETWEEN ELEMENTS

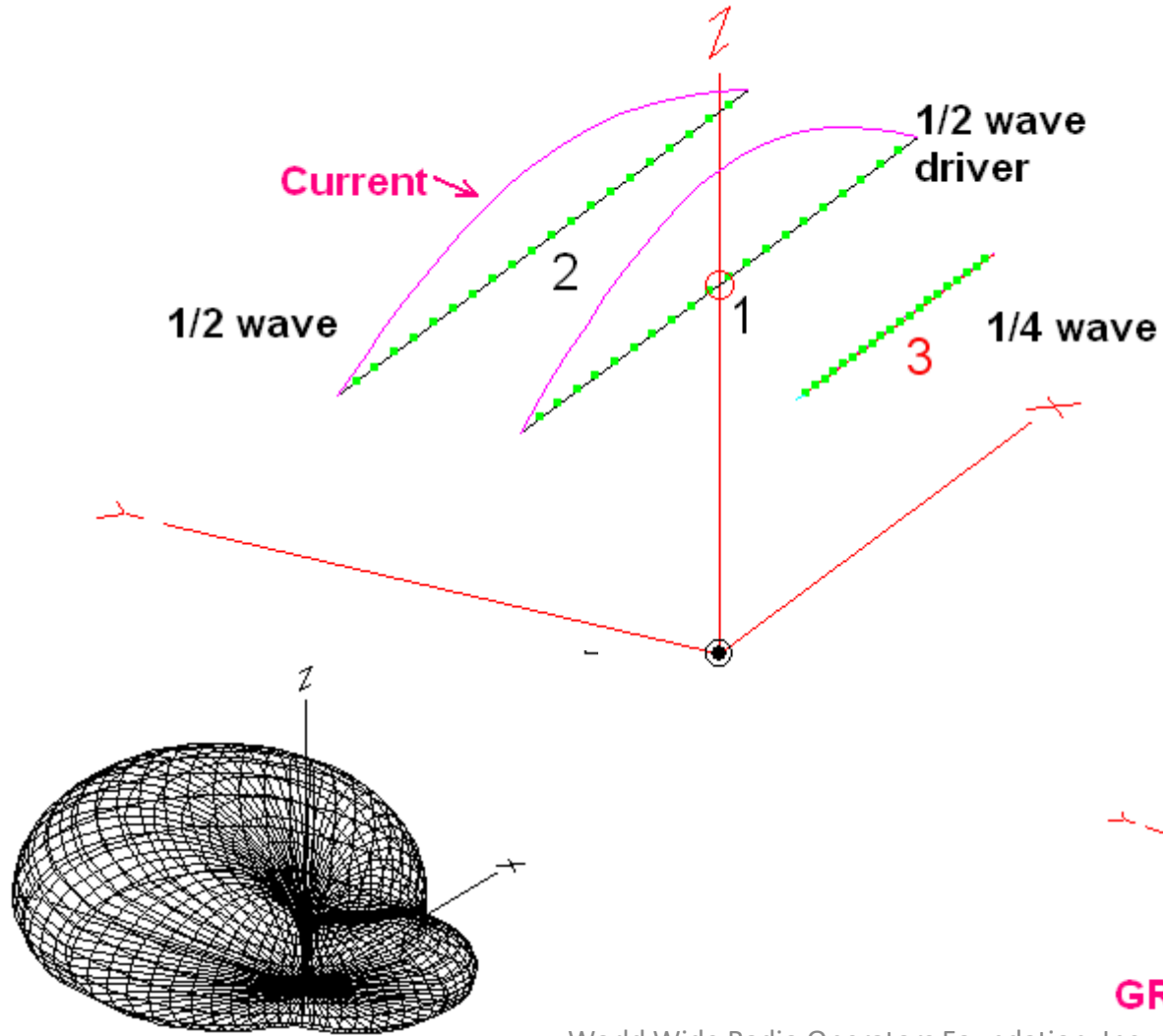

- Maximum interaction $\frac{1}{2}$ wave
- Minimum interaction $\frac{1}{4}$ wave

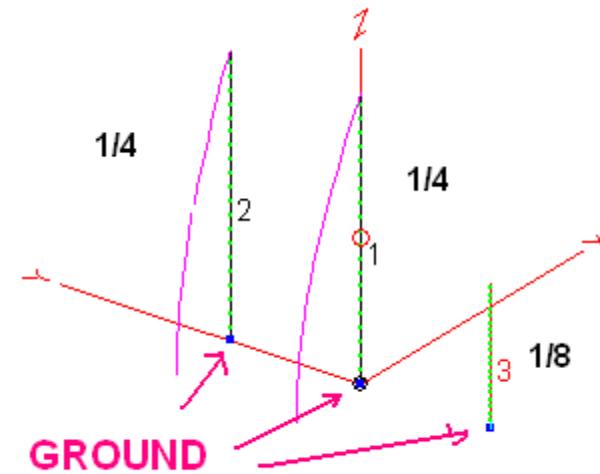

TX antenna is not the only resonant element in your station

ALL CABLES, FEED LINES, ROTOR CABLE AND METAL STRUCTURES MUST BE DETUNED TO PREVENT DEGRADED RADIATION PATTERN

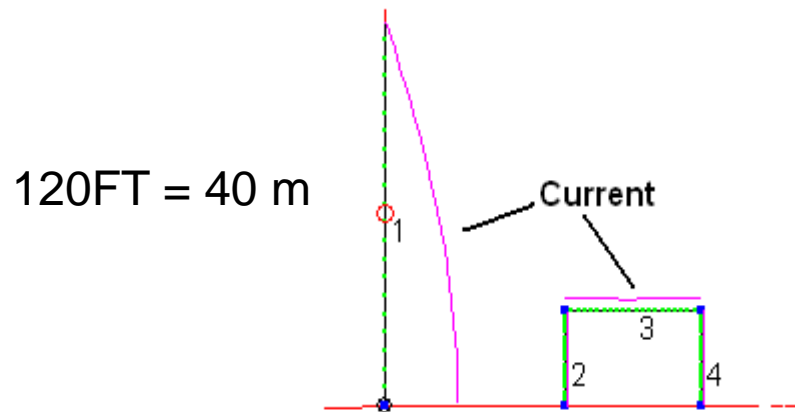

Changing the impedance Z_{in} or Z_{out} does not detune the feedline cable

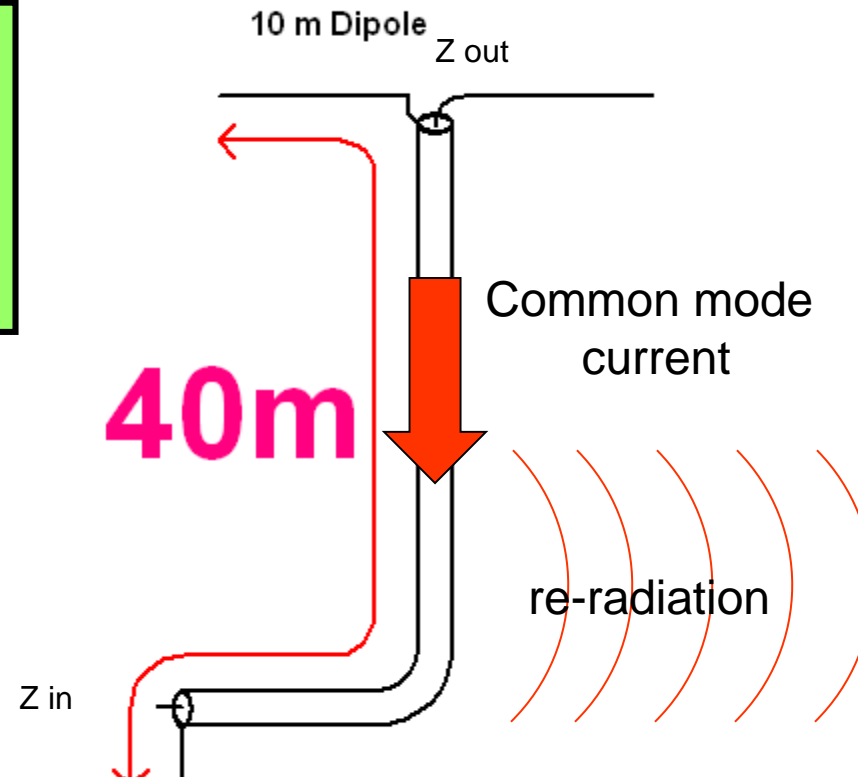

Easy way to kill all your RX antennas is; Low dipole and $\frac{1}{4}$ wave elevated radials

DEGRADED RADIATION PATTERN

ALL SIGNAL MIXING AT PREAMPLIFIER INPUT

OPEN FRAME RELAY – PLASTIC BOX -OPEN SHIELD CONNECTOR

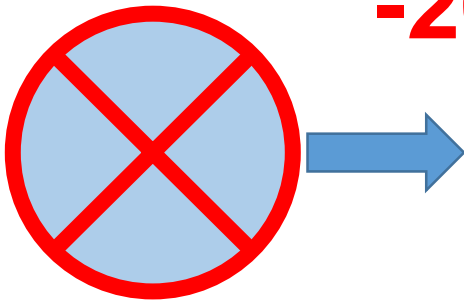
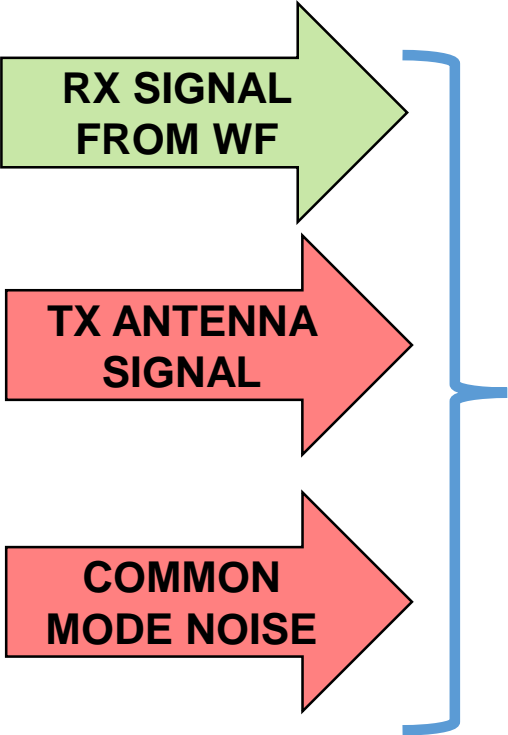

0 dB
-10 dB
-20 dB

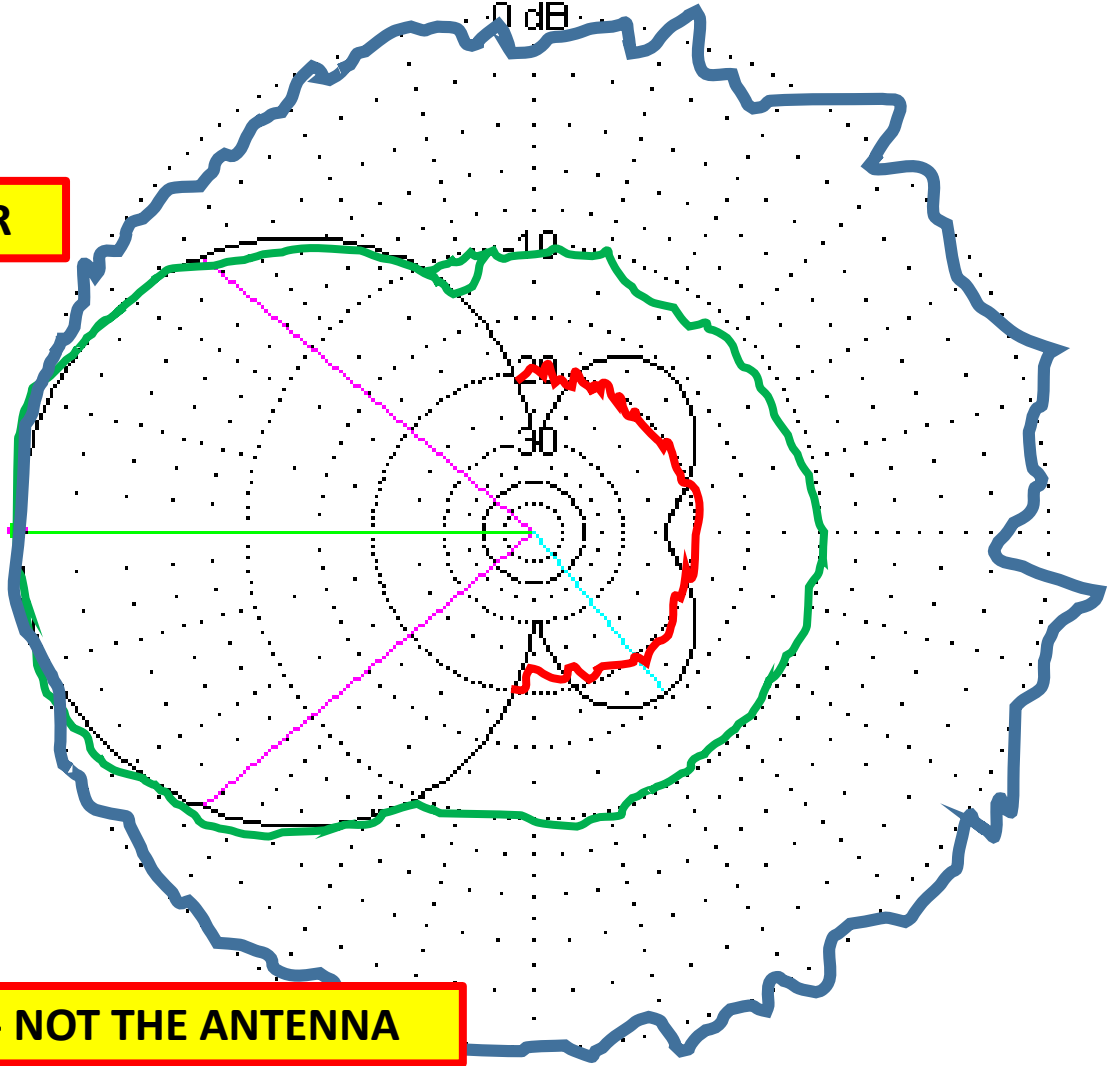

PREAMPLIFIER IS PART OF THE RADIO - NOT THE ANTENNA

NX4D >> When the WF is beaming 90° or less toward the tower, I get 1.5 to 2.0 S-units of noise reduction. Removing the center coax cable conductor from the tower helps some, but neutralizing the tower is a big noise reduction.

PY2XB >> Antenna Detuning - Relay Boxes: In order to not jeopardize the RX Flag antenna's pattern, it is necessary to avoid interaction with nearby antennas or structures. The relays are operated in such way that, on receiving, the 80m folded dipole and the 160m sloper are not "seen" by the RX Flag antenna.

- <https://www.flickr.com/photos/133647736@N07/sets/72157653478604348/>

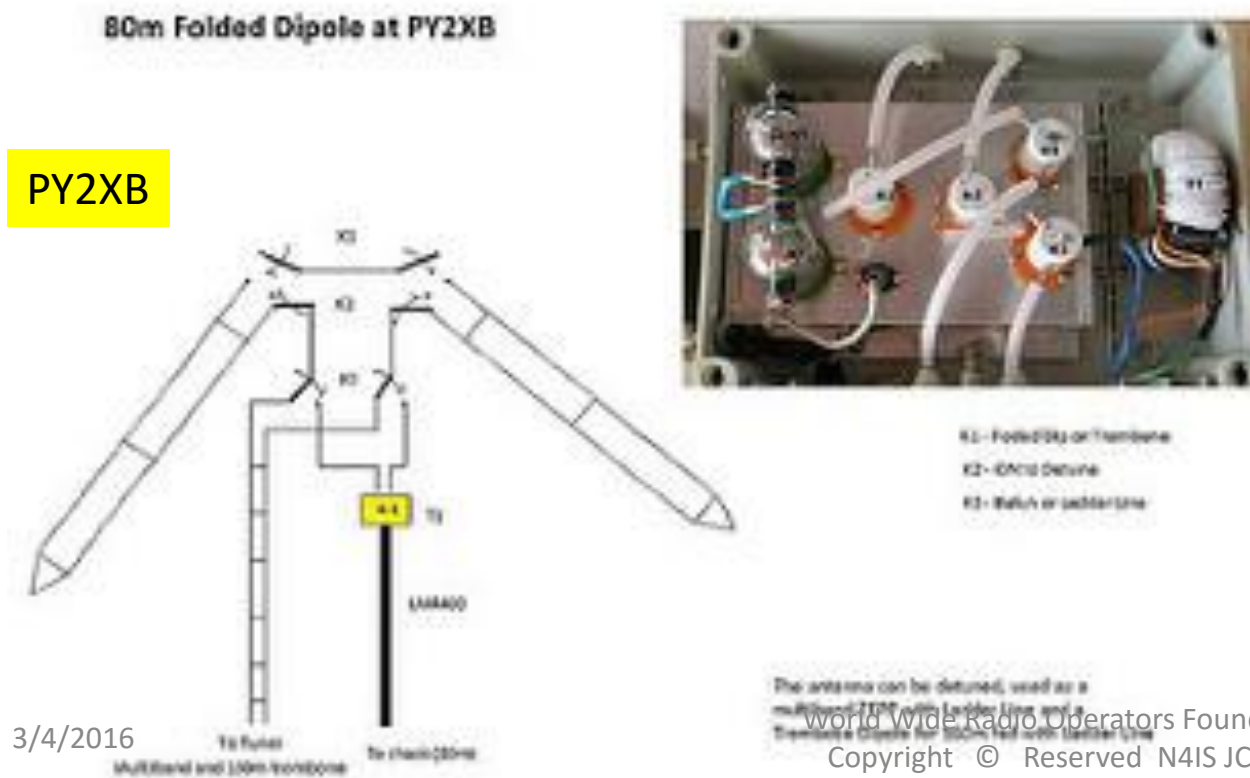

Protecting RX feed lines from common mode noise

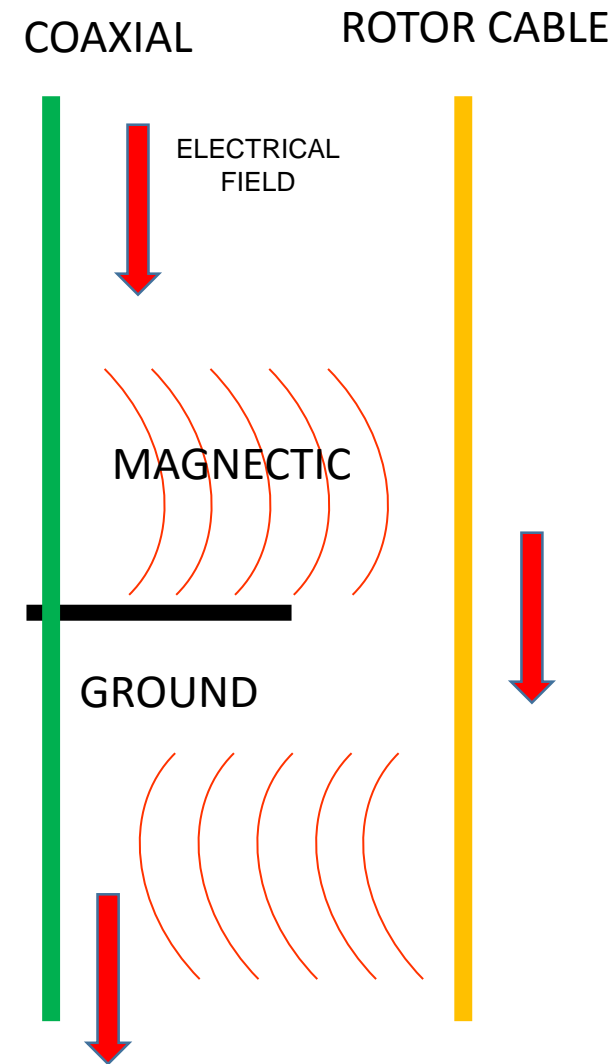
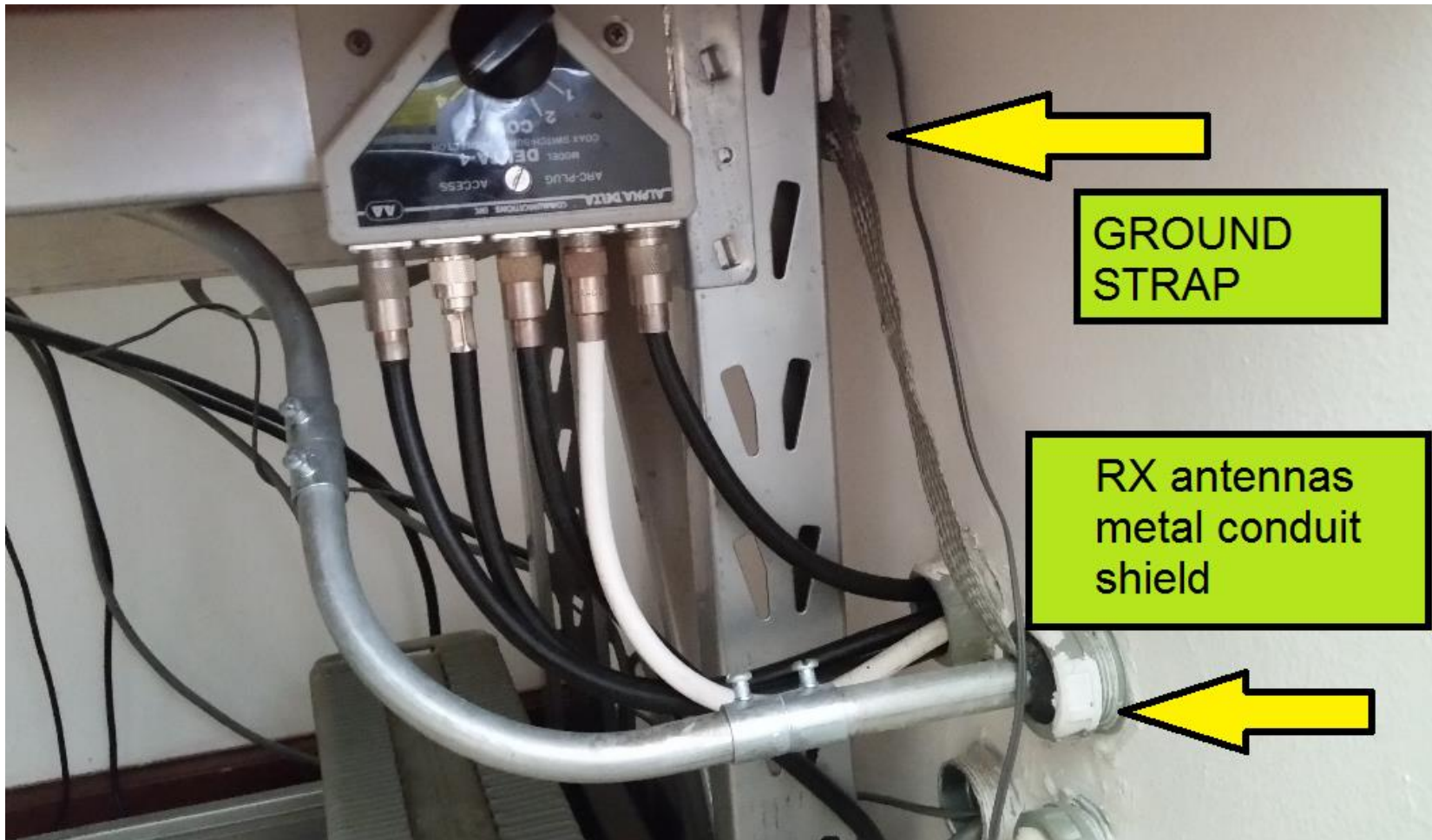

Protecting RX feed lines from common mode noise

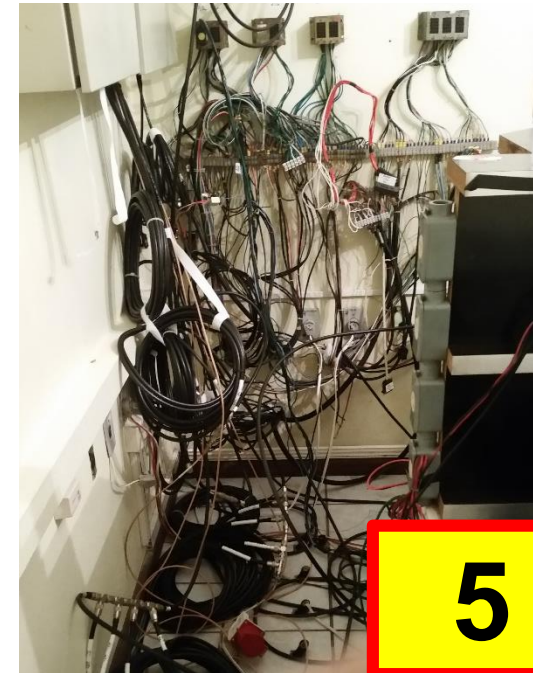
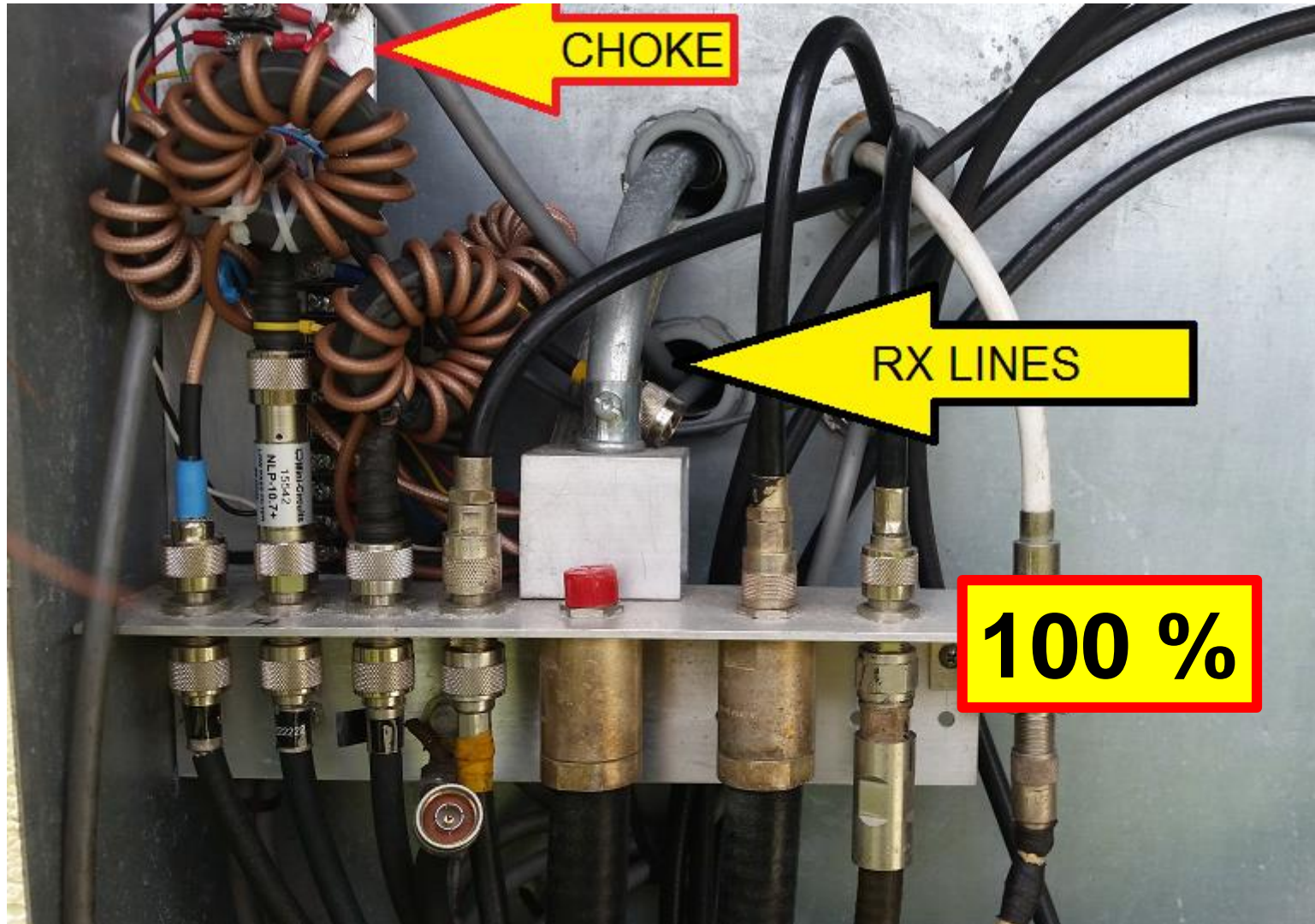

Protecting RX feed lines from common mode noise

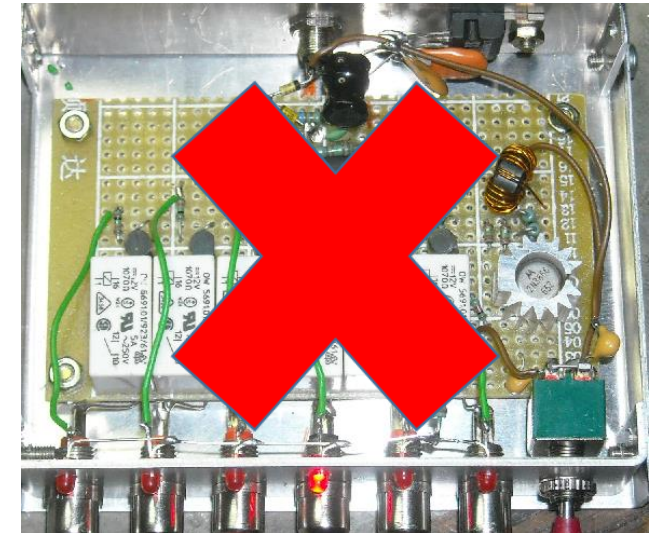

N4IS PREAMPLIFIERS

Preamp Filter Interlock Unit

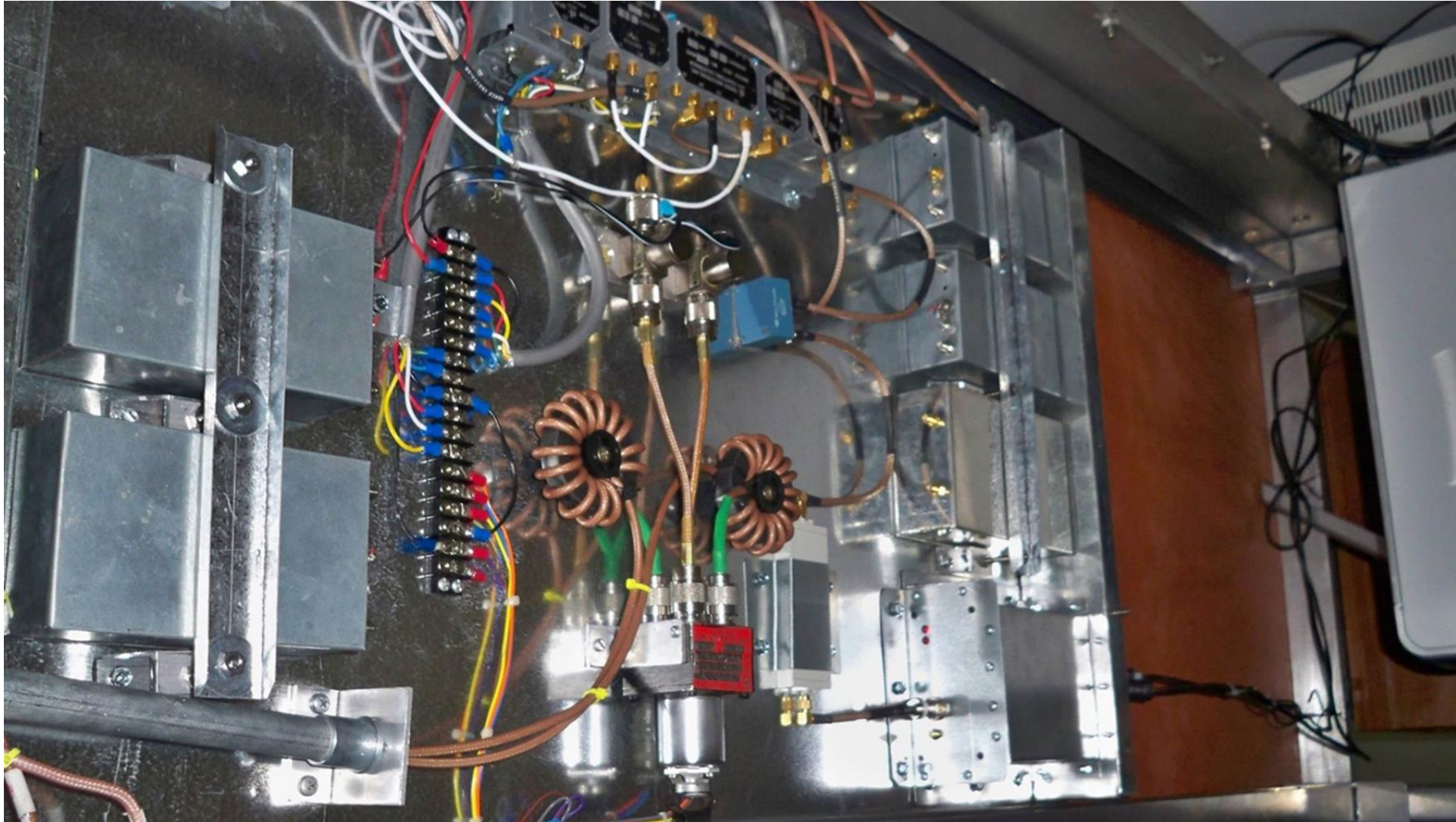

N4IS PREAMPLIFIERS

Preamp Filter Interlock Unit

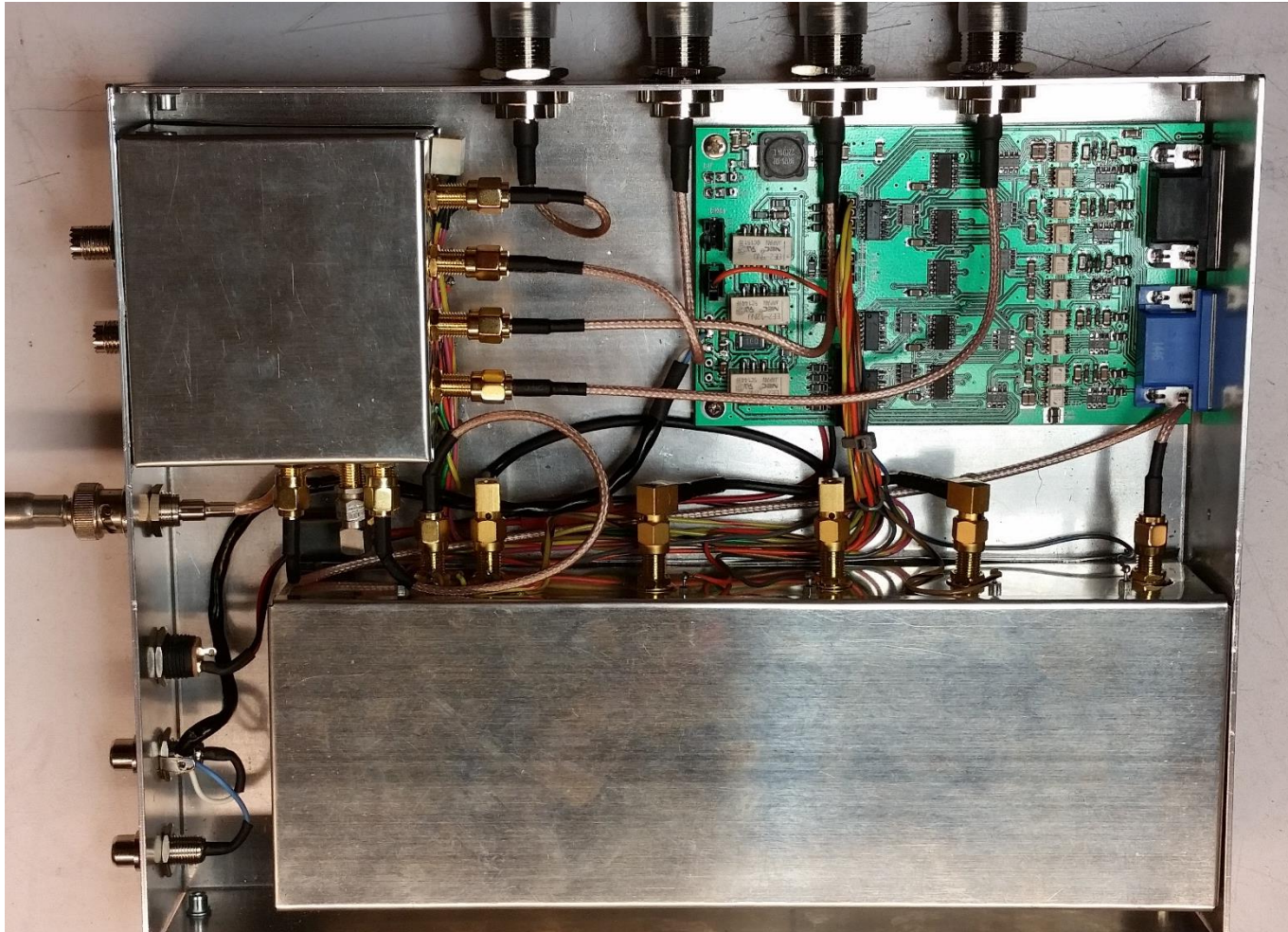

WF system is a one year long project

Low system Noise Figure < 2 dB

CHOKER is your best friend

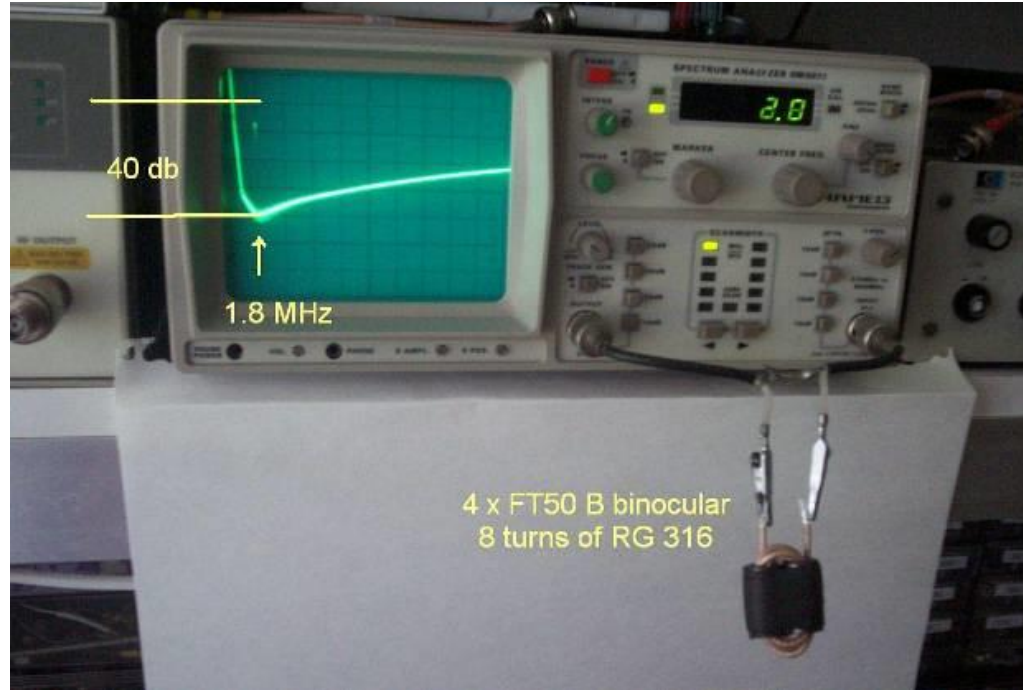

Steve Dove W3EEE *Reducing EMI Noise on Receive Antennas*

<http://www.hifidelity.com/w3eee/Noiz%20.html>

**Common mode current runs outside the shield , if you open the shield the noise get's inside !
CHOKE IS YOUR BEST FRIEND**

A Ham's Guide to RFI, Ferrites, Baluns, and Audio Interfacing by Jim Brown K9YC

<http://audiosystemsgroup.com/RFI-Ham.pdf>

Common-Mode Chokes 1 by Chuck Counselman, W1HIS

<http://www.yccc.org/Articles/W1HIS/CommonModeChokesW1HIS2006Apr06.pdf>

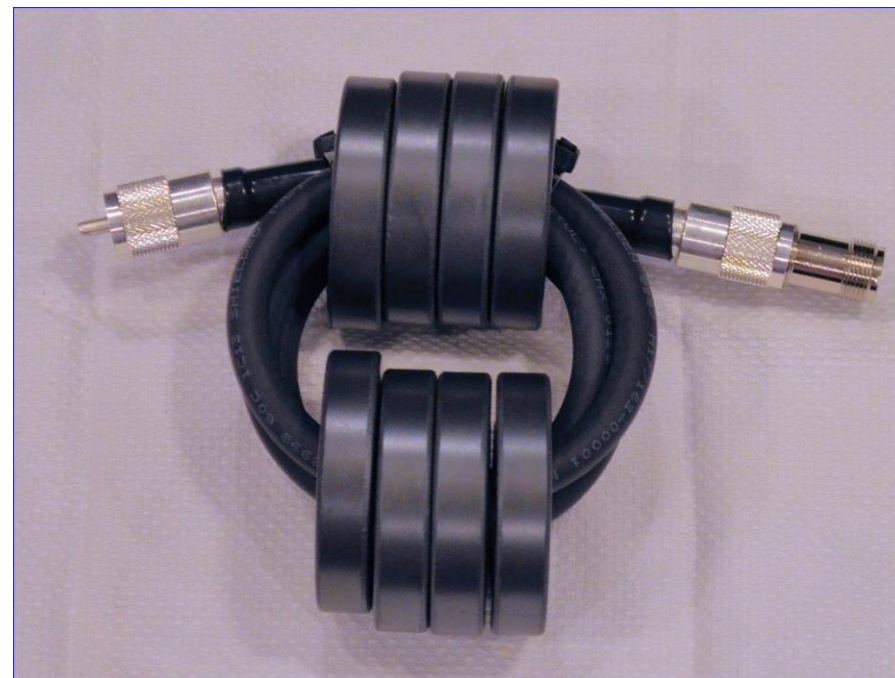

N4IS 220 V ac Filter



Crimp On PL-259 Connectors PLEASE !!!!!

http://www.bcdxc.org/pl259_crimp_on_connectors.htm

<http://www.eham.net/articles/19257>



I am using "N" and SMA connectors only

One BAD connector increase noise 2-4 S units

PY1RO single HWF

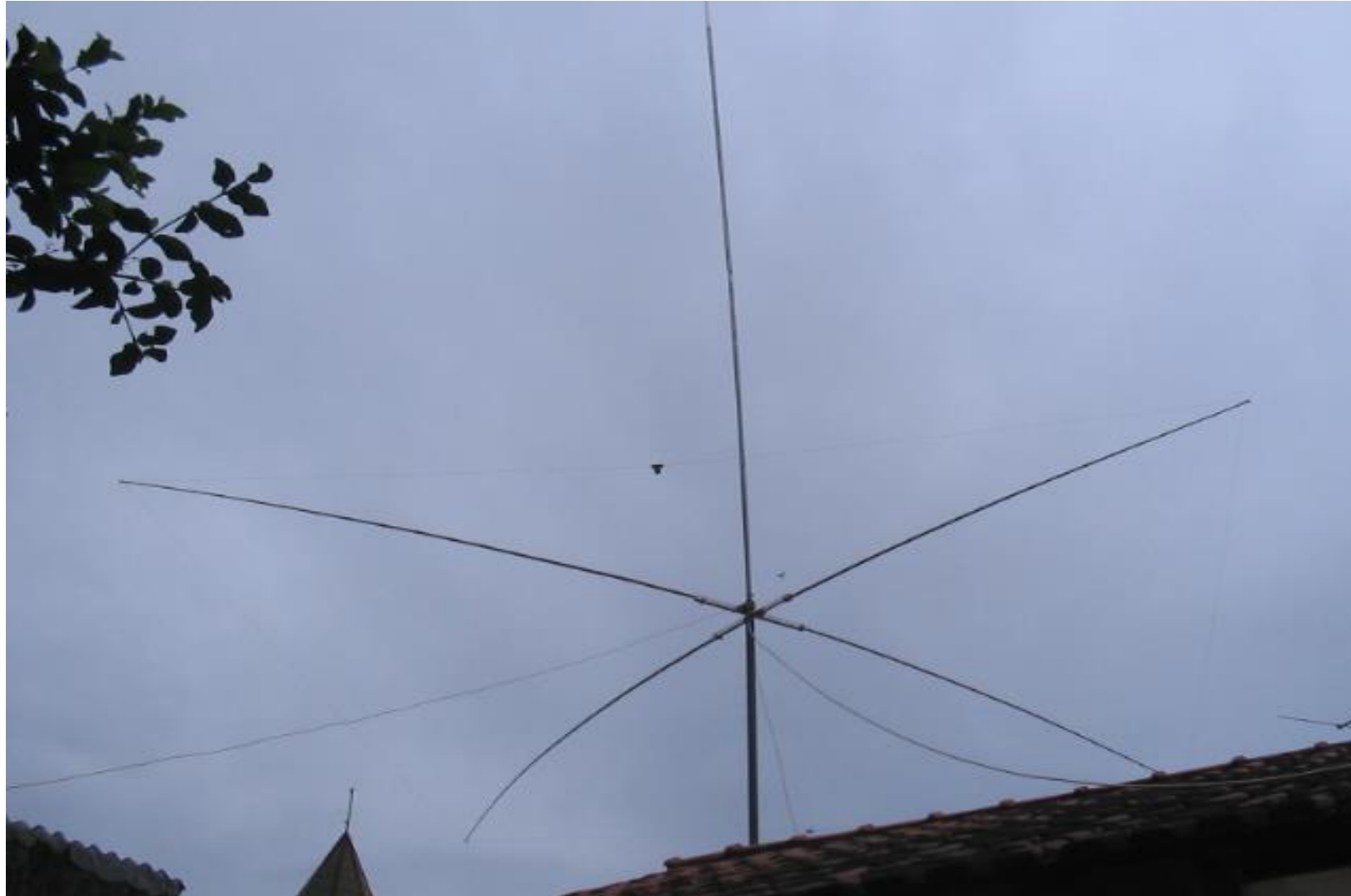

PY1RO single HWF

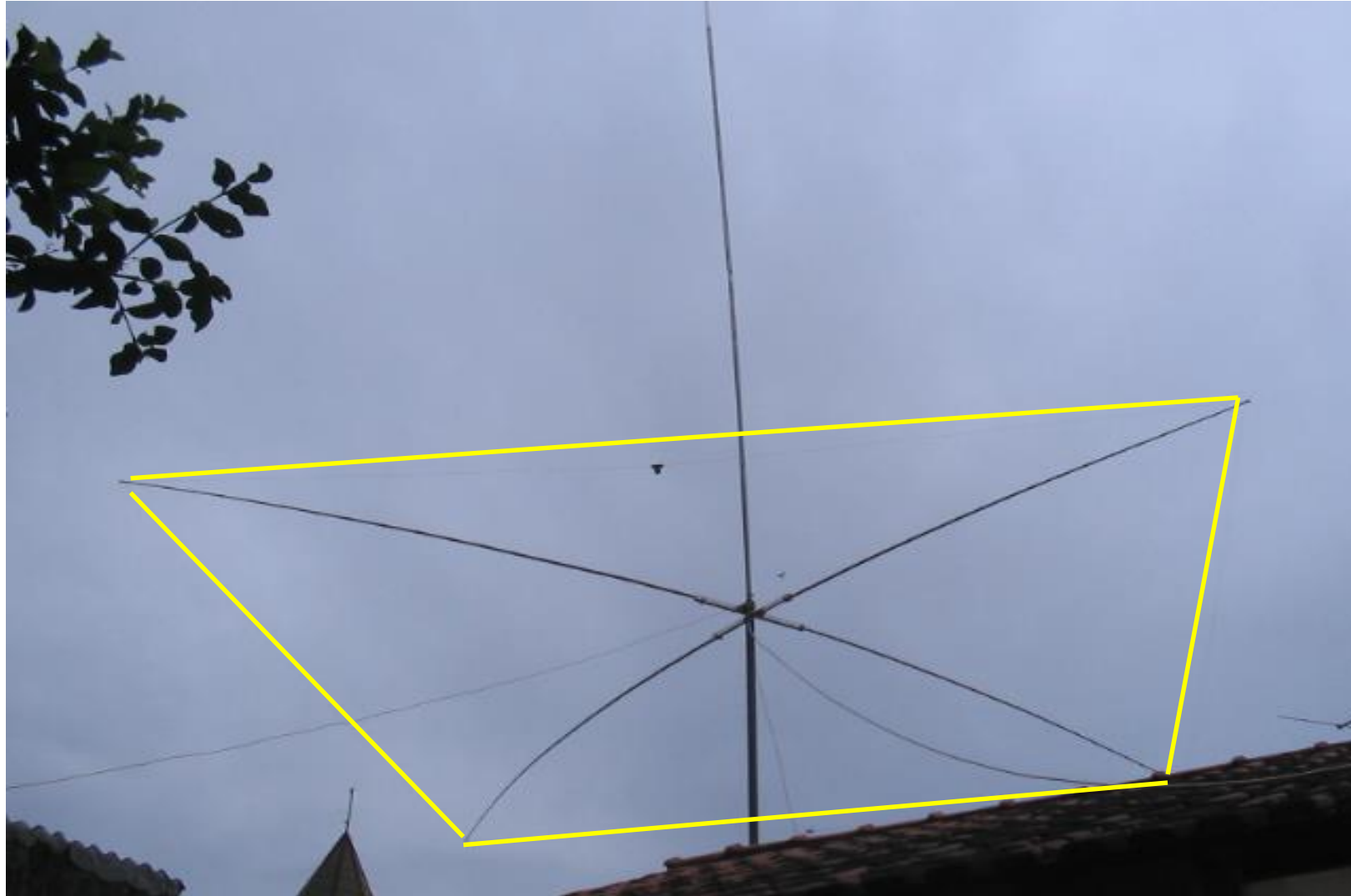

THAT IS IT!

OR IS THERE MORE TO COME?

FIFTH STEP >> N8PR UNIQUE Polarization Tilt HWF



SIXTH STEP SDR BEAM FORMING WITH 4 LOOPS (70 FT)

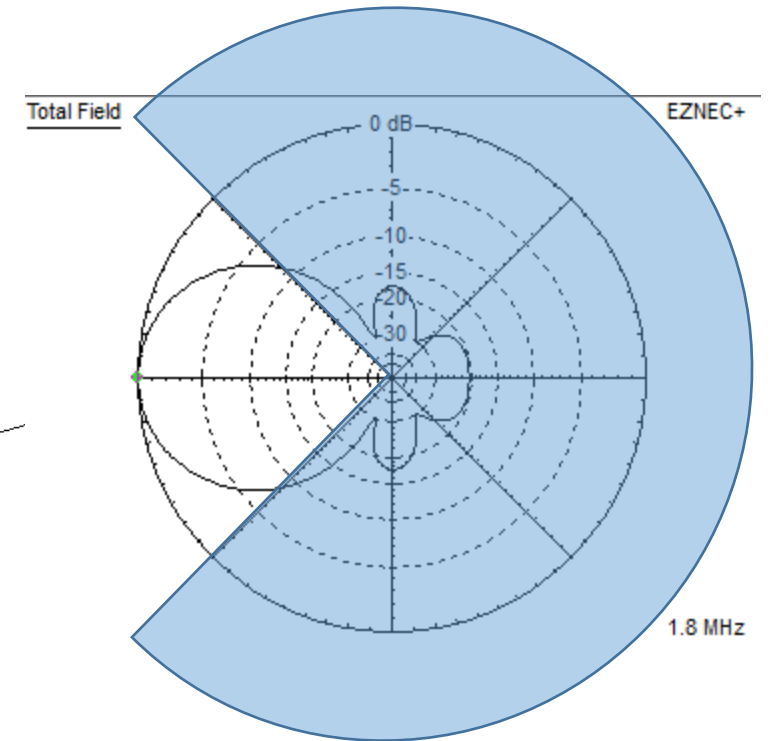
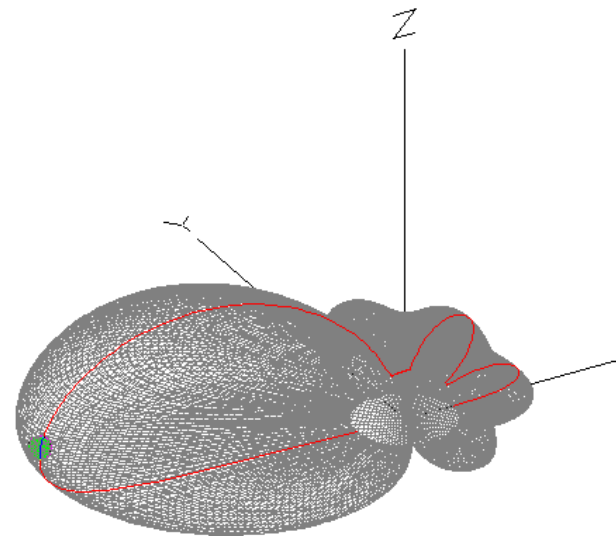

14.3 dB RDF 53 degree front lobe

Conclusions

- Noise is up!
- More noise coming: LED lights, VFD-s, Electric Car-Chargers!
- Not everybody has room for Beverages in city lots
- Vertical Waller Flag: Excellent but noisy
- Horizontal Waller Flag: Low noise, practical size
- The RX antenna for the urban Top-bander

Dual loaded loop receiving antenna

Historical Evolution

1919 March 5, 1919, Roy A. Weagant, Chief Engineer of the Marconi Wireless Telegraph Co. of America, delivered a paper describing in detail his apparatus for the elimination of the great bug-bear of transoceanic wireless communication -- static interference. >>

<http://infoage.org/html/wa-1919-04-p11.html>

1938 Harold Beverage invented wide band receiver antenna, loaded loop. The present invention relates to short wave antennas and, more particularly, to antennas for receiving horizontally polarized waves over a wide band of frequencies. An object of the present invention is to enable the reception of horizontally polarized signals over a wide band of frequencies such-as is at present used in television.

<https://docs.google.com/viewer?url=patentimages.storage.googleapis.com/pdfs/US2247743.pdf>

1940. Nearly all the newly re-invented compact receive antennas derive from the terminated loop, the earliest reference **was in an appallingly mimeographed prewar training manual of W3EEE Dad's**

1973 **COMMUNICATIONS 74 CONFERENCE BRIGHTON** Wednesday, June 5 1974 — Session 5 Equipment Design
Paper 5.3: Loop Antennas for HF Reception Contributed by: B.S.Collins, C & S Antennas Ltd.,

- 1995 JF1DMQ wrote an [earlier article](#) about the Flag antenna in November 1995 in a Japanese magazine. His was only 3.3 feet by 16.4 feet long (1 by 5 m).K6SE's 160m optimized versions are 14 by 29 feet (4.3 by 8.8m).
- 1995 "Is This EWE for You?" (QST February, 1995, p.31) and "More EWES for You", QST January, 1996, p. 32) both by **WA2WVL**.
- 1996 The Pennant was originated by **EA3VY** and optimized for 160 meters by **K6SE**, who first wrote about them on the [Top Band Reflector](#) in 1998
- 1997 The **K9AY** Terminated Loop—A Compact, Directional Receiving Antenna By Gary Breed, **K9AY**
- 1998 **W7IUV** rotatable Flag and preamplifier >> <http://w7iuv.com/>
- 2000 QST Magazine, July 2000, page 34 for **K6SE**'s classic article: "Flags, Pennants, and Other Ground-Independent Low-Band Receiving Antennas" ...
- 2003 **NX4D** developed the first dual flag vertical array
- 2006 **N4IS** developed the BIG flag vertical array >> www.n4is.com
- 2008 **N4IS** developed the Horizontal flag array
- 2009 **Dr Dallas Lankford**, wrote the Flag Theory and design the Quad Flag Array >> Dallas Files
The Dallas Files are now found here: <http://groups.yahoo.com/group/thedallasfiles2>
- 2009 AA7JV George Wallner developed the DHDL (TX3A) >> http://tx3a.com/docs/TX3A_DOUBLE_HALF_DELTA_LOOP.ZIP
- 2009 DOUBLING the Double Half-Delta Loop Receiving Antenna
by Pierluigi "Luis" Mansutti IV3PRK >> http://www.iv3prk.it/user/image/..-rxant.prk_tx3a.pdf

Pre War terminated loop

1940 Pre War terminated loop

THE RADIATION PATTERN OF LOOP ANTENNAS

The current which flows in a loop antenna **may be** represented by a Fourier series of cosine and sine terms. The zero order term represents a constant current flowing around the loop and gives rise to the familiar figure-of-eight radiation pattern typical of a small loop.

The odd order (sine) terms represent the currents which flow in the same direction in both sides of the loop and therefore do not give rise to any output voltage across a balanced terminating impedance. The azimuth radiation pattern associated with this current mode in a small loop is circular. When the loop is fed with an unbalanced feed both even and odd modes can exist. The total radiation pattern of the loop will be the sum of those due to the separate modes. The zero order mode predominates in a simple loop; in order to obtain a cardioid radiation pattern the amplitude of the zero order mode current must be reduced relative to the first order mode current, and the relative phase of the currents must be adjusted so that the cancellation obtained in the rearwards direction is complete. This result can be achieved by inserting a suitable impedance in series with the loop at a point diametrically opposite the feed point.

The terminated loop exhibits a near cardioid azimuth radiation pattern for vertically polarized incident energy and an input impedance which may easily be matched to 50 ohms.

Flag EWE K9AY Delta Pennant = LOADED LOOP

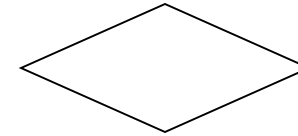
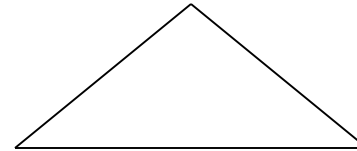

+ Resistor and Transformer

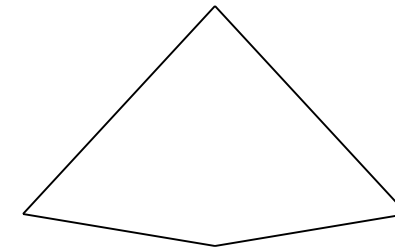
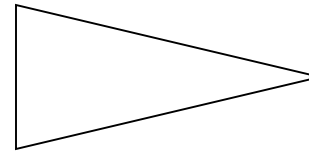

TWO VERTICALS IN PHASE

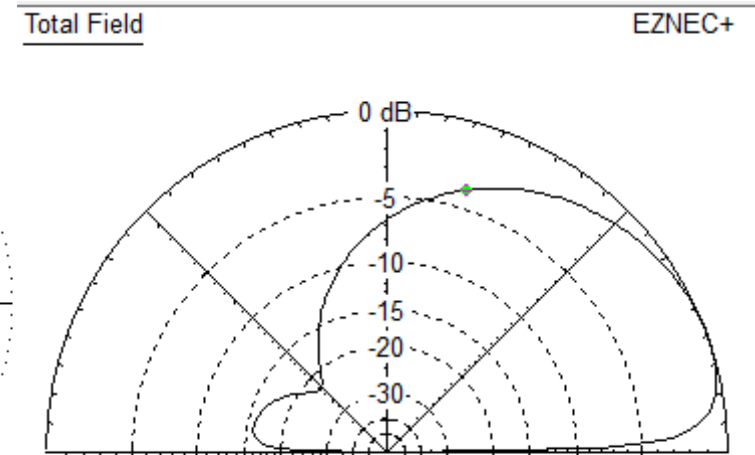
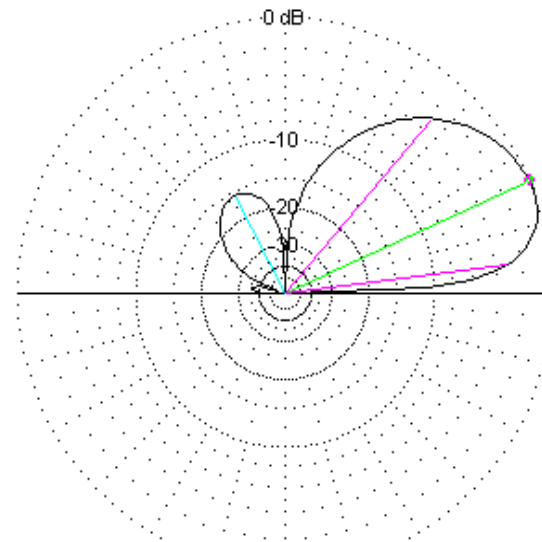
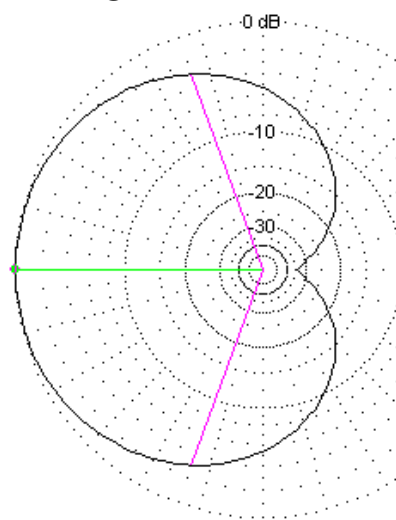
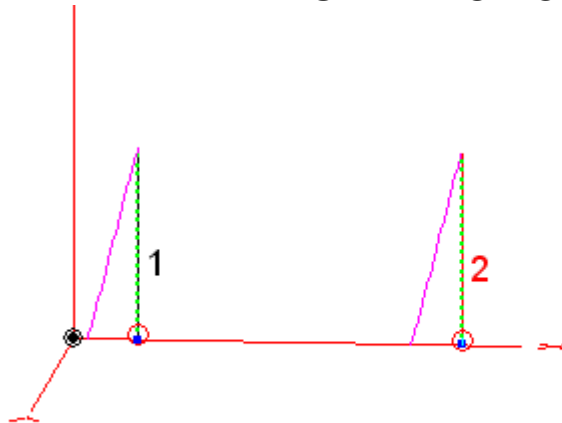

Dual Half Dual Loop AA7JV

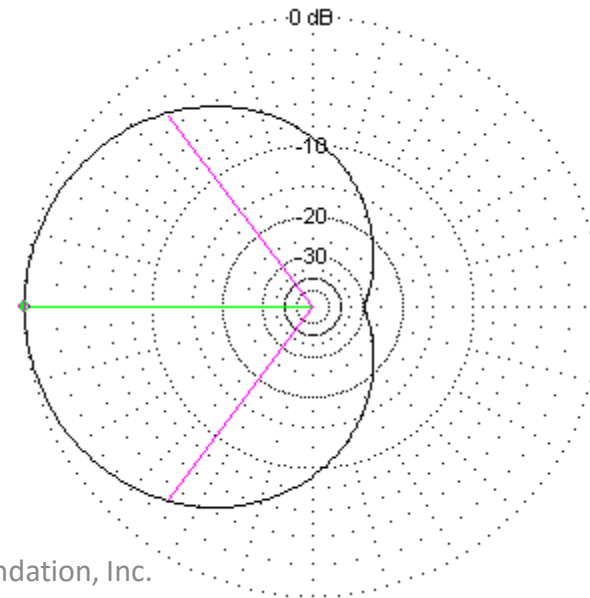
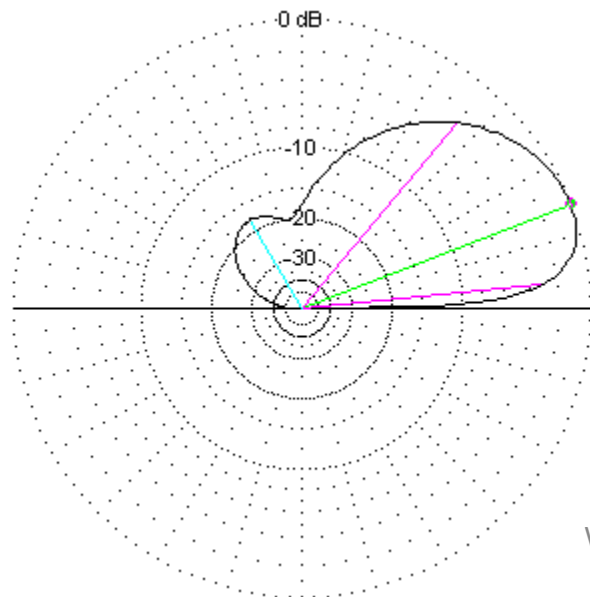
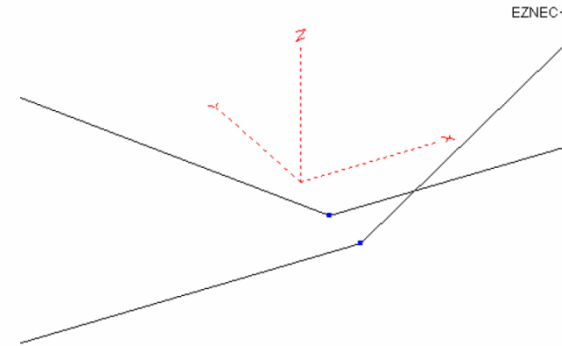
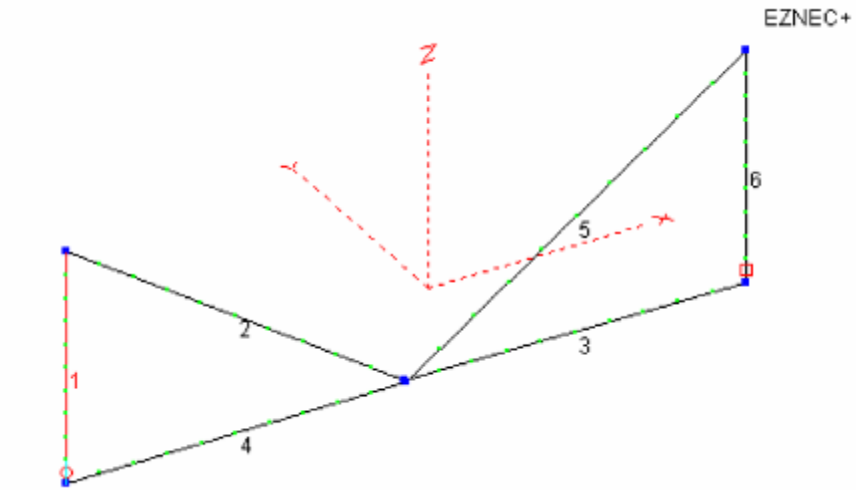

Vertical Waller Flag

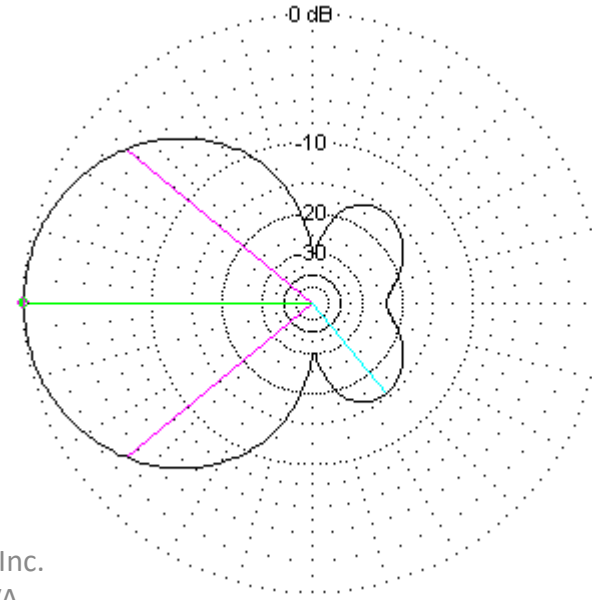
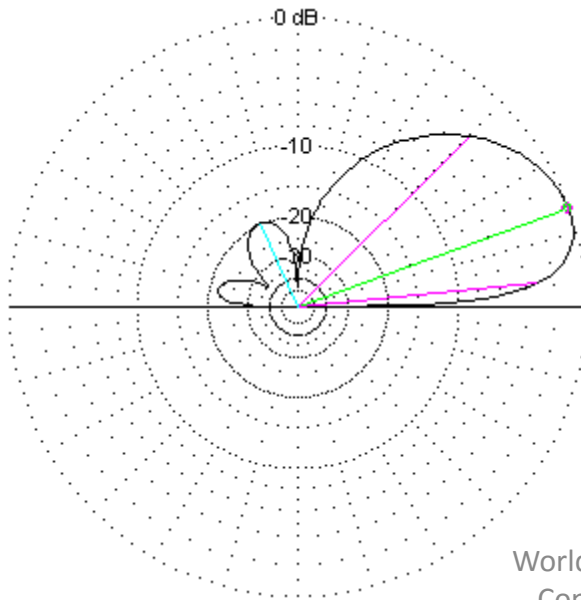
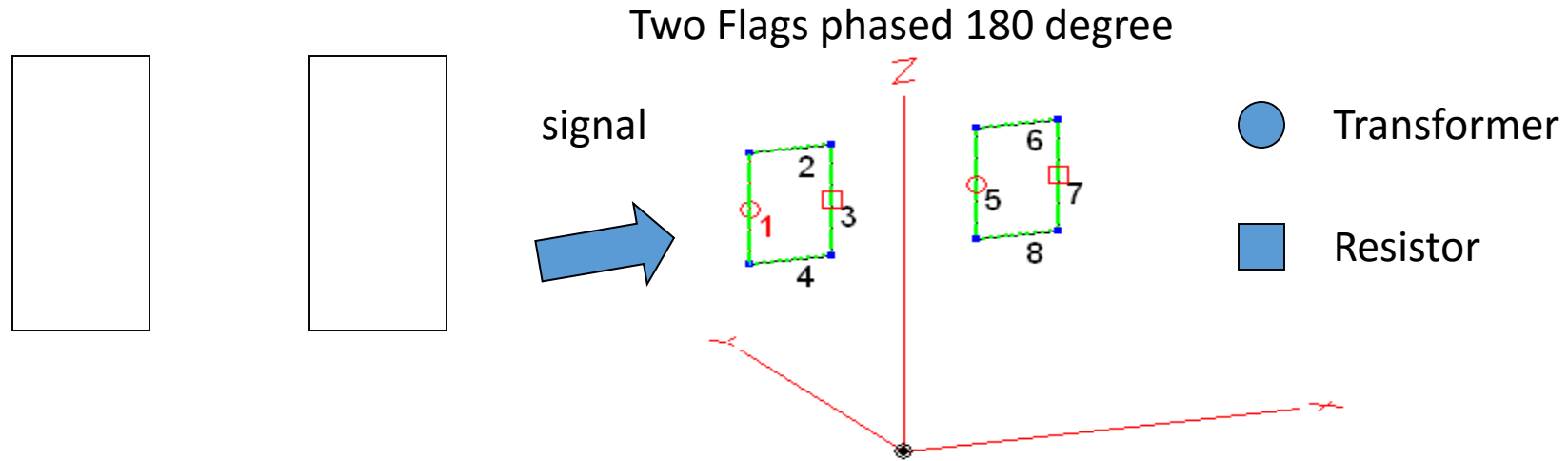

Phased Delta Flag Arrays

Dallas Lankford, 2/21/09, rev. 4/23/10

The delta antenna is a variant of the flag antenna. The earliest delta flag antenna I am aware of was designed by K6SE and constructed by ON4UN for use by FO0AAA some time before June 2000. While it was designed for the 160 meter ham band, it probably worked well in the MW band. I became interested in phased delta flag arrays because I wanted to experiment with quad phased flag arrays for splatter reduction in the MW band; see my article “Phased Flag Arrays” in The Dallas Files . My flag array experiments were inspired by the phased rotatable dual flag arrays of NX4D and N4IS, but inexpensive masts are not good for flag construction because of sag problems.

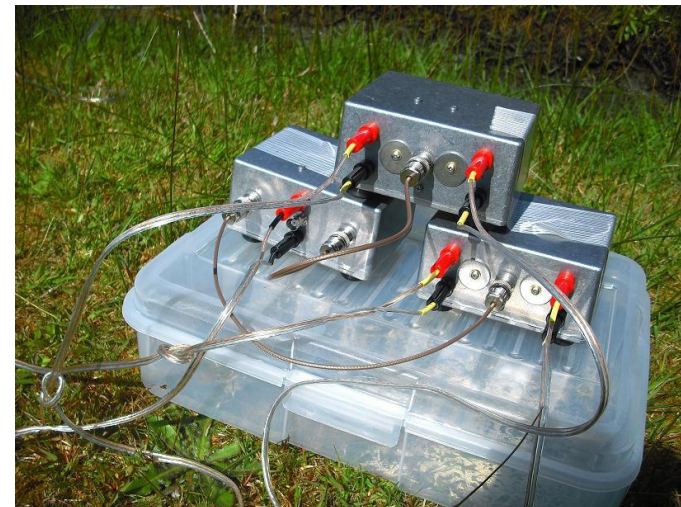

Phased Delta Quad Flag Arrays

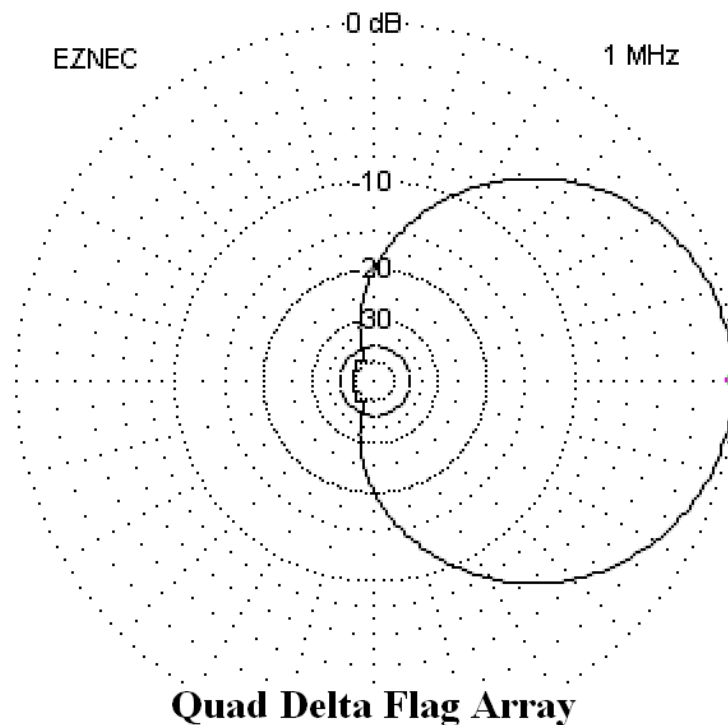

> 50 db F/B F/S 180 degree

The Dallas Files are now found here:
<http://groups.yahoo.com/group/thedallasfiles2>

Phased Delta Flag Arrays

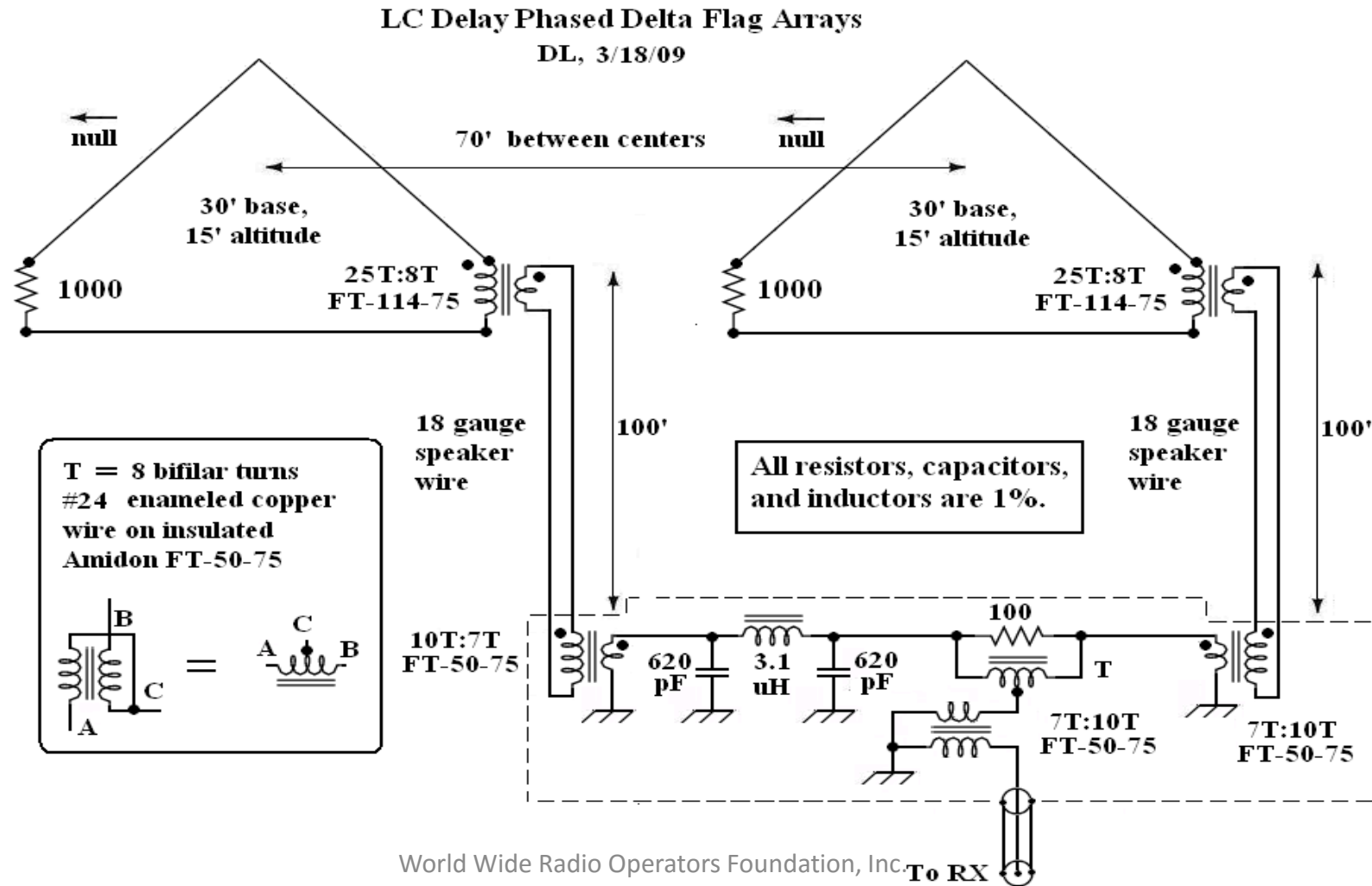

Phasing and Feeding

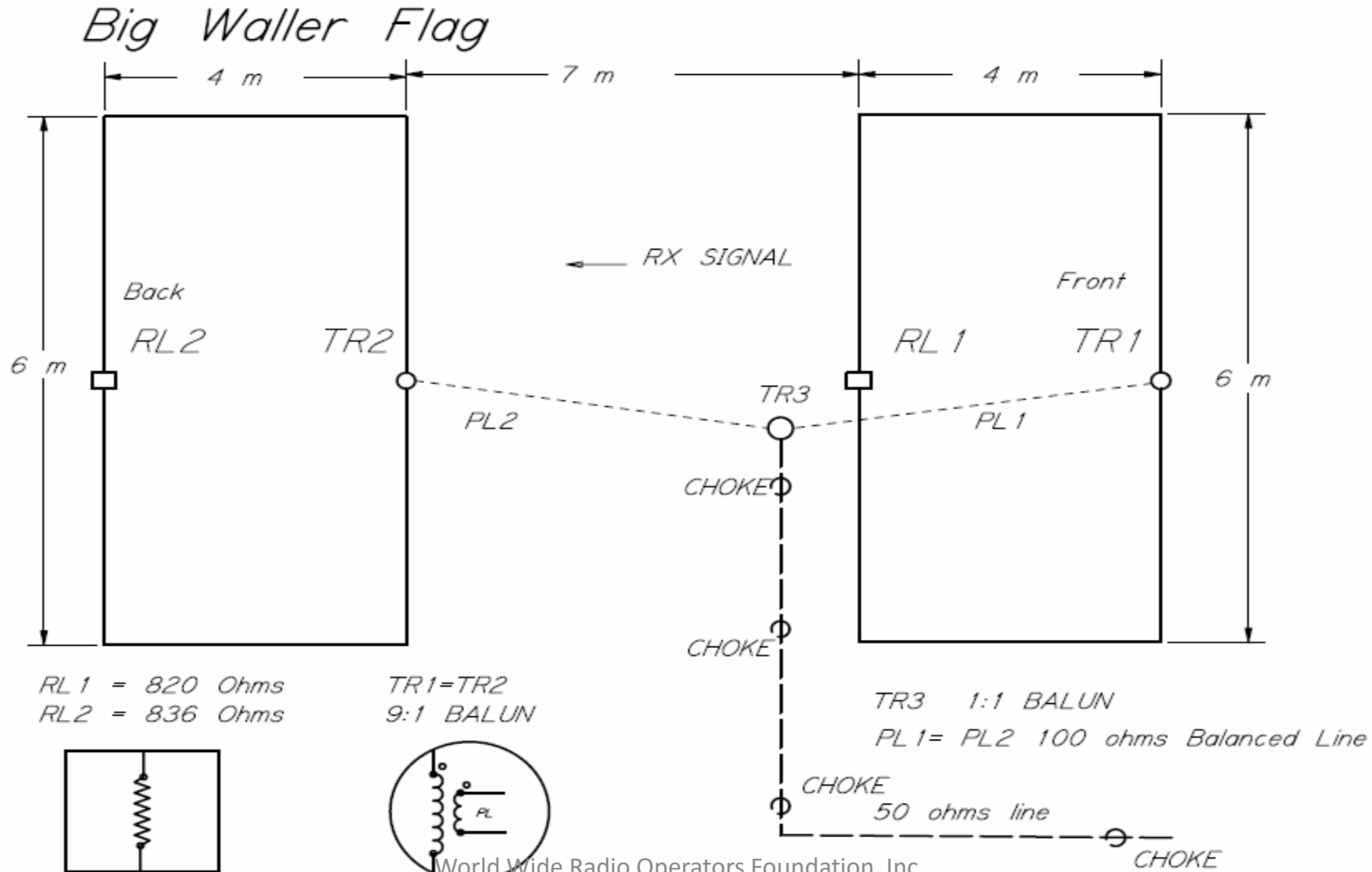

Phasing details of Waller Flag

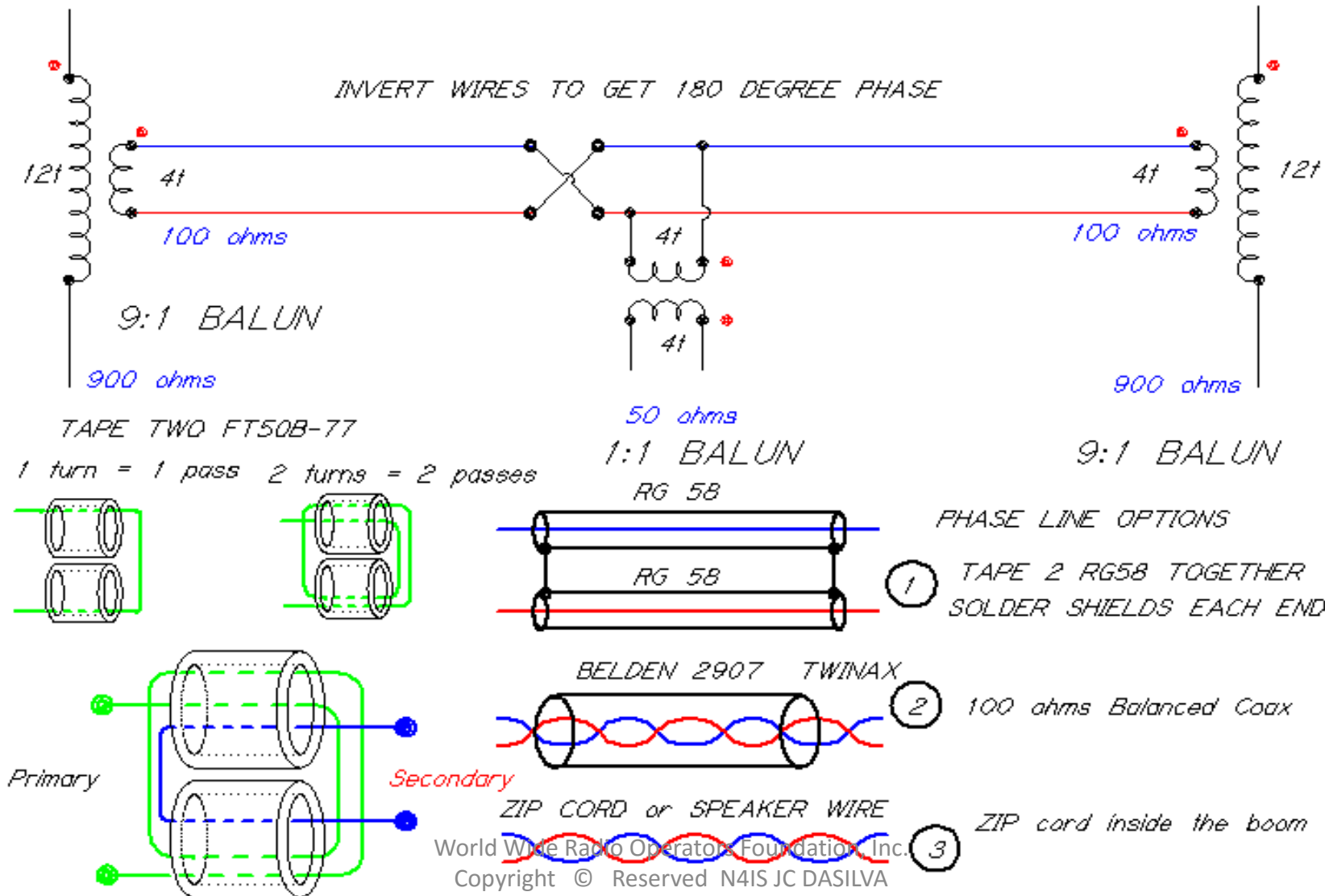

HWF Horizontal Waller Flag pictures PT9ZE N4IS PP5JR



HWF Horizontal Waller Flag pictures K4FL N4BRF

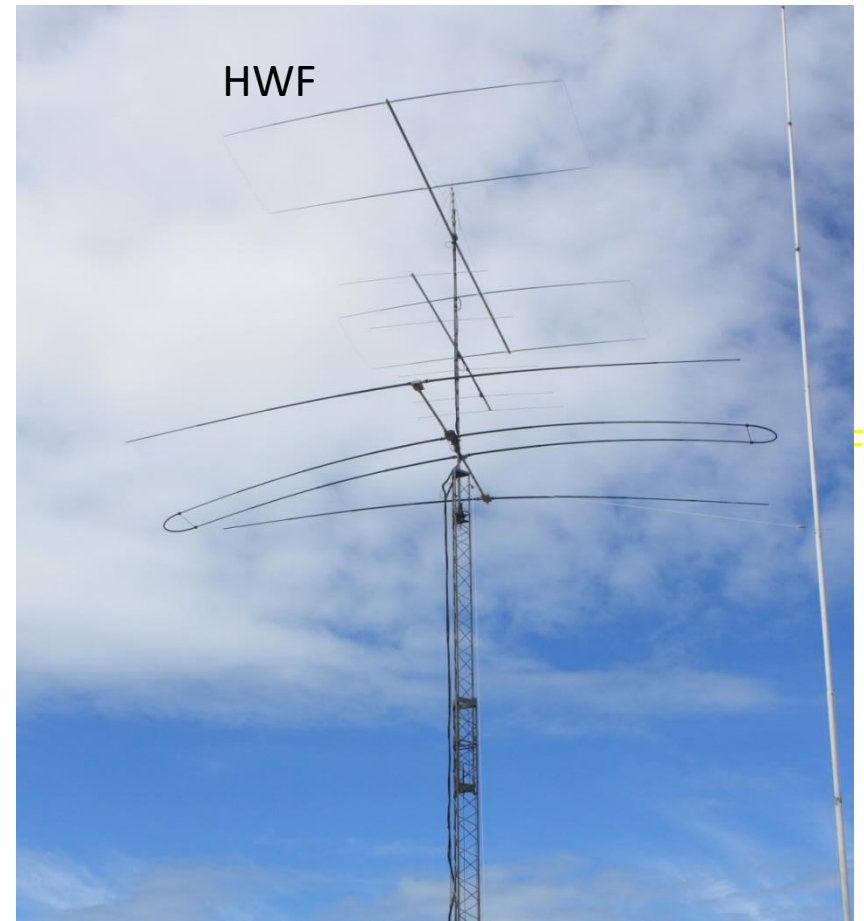

HWF Horizontal Waller Flag pictures

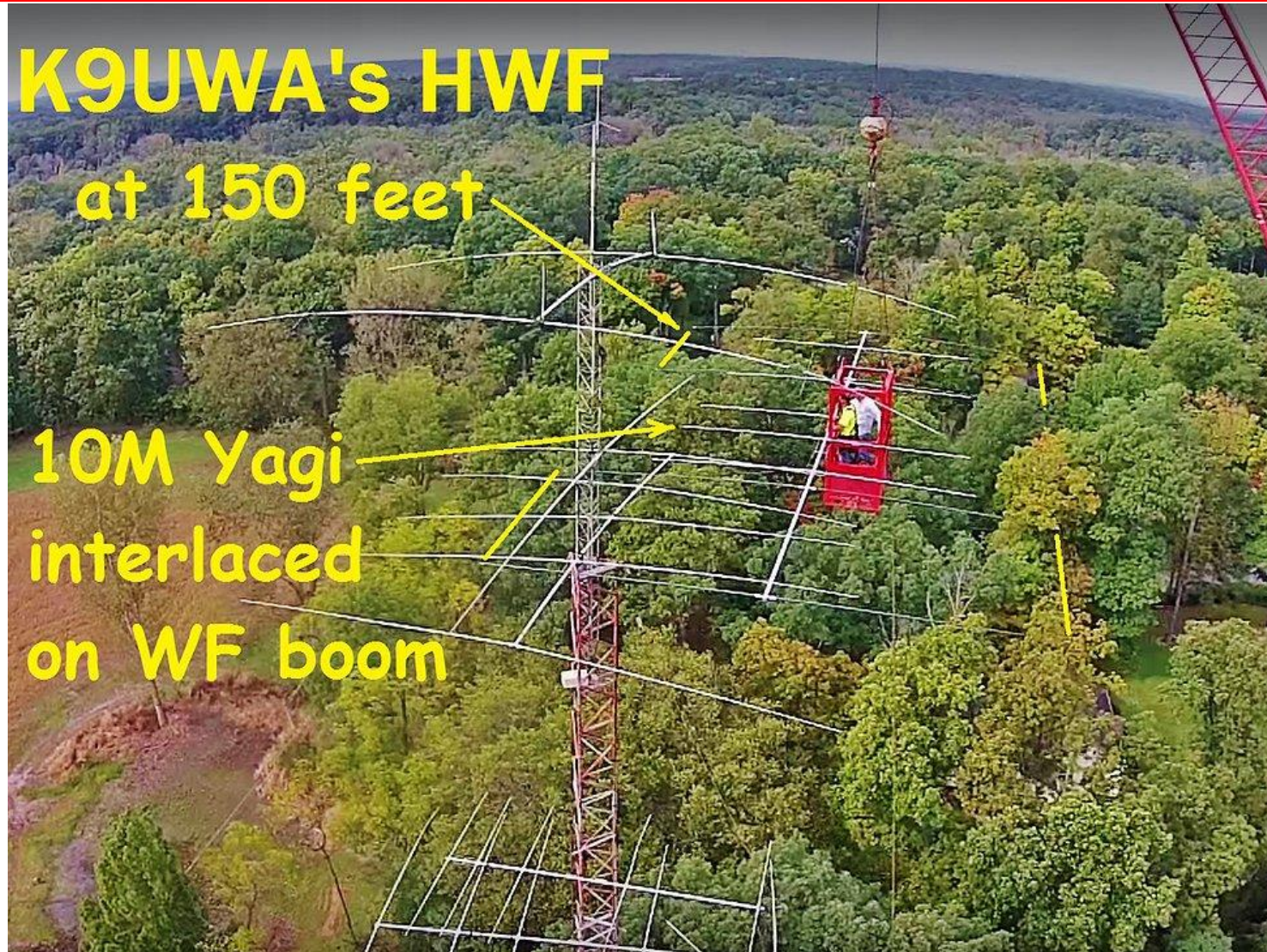

HWF Horizontal Waller Flag pictures

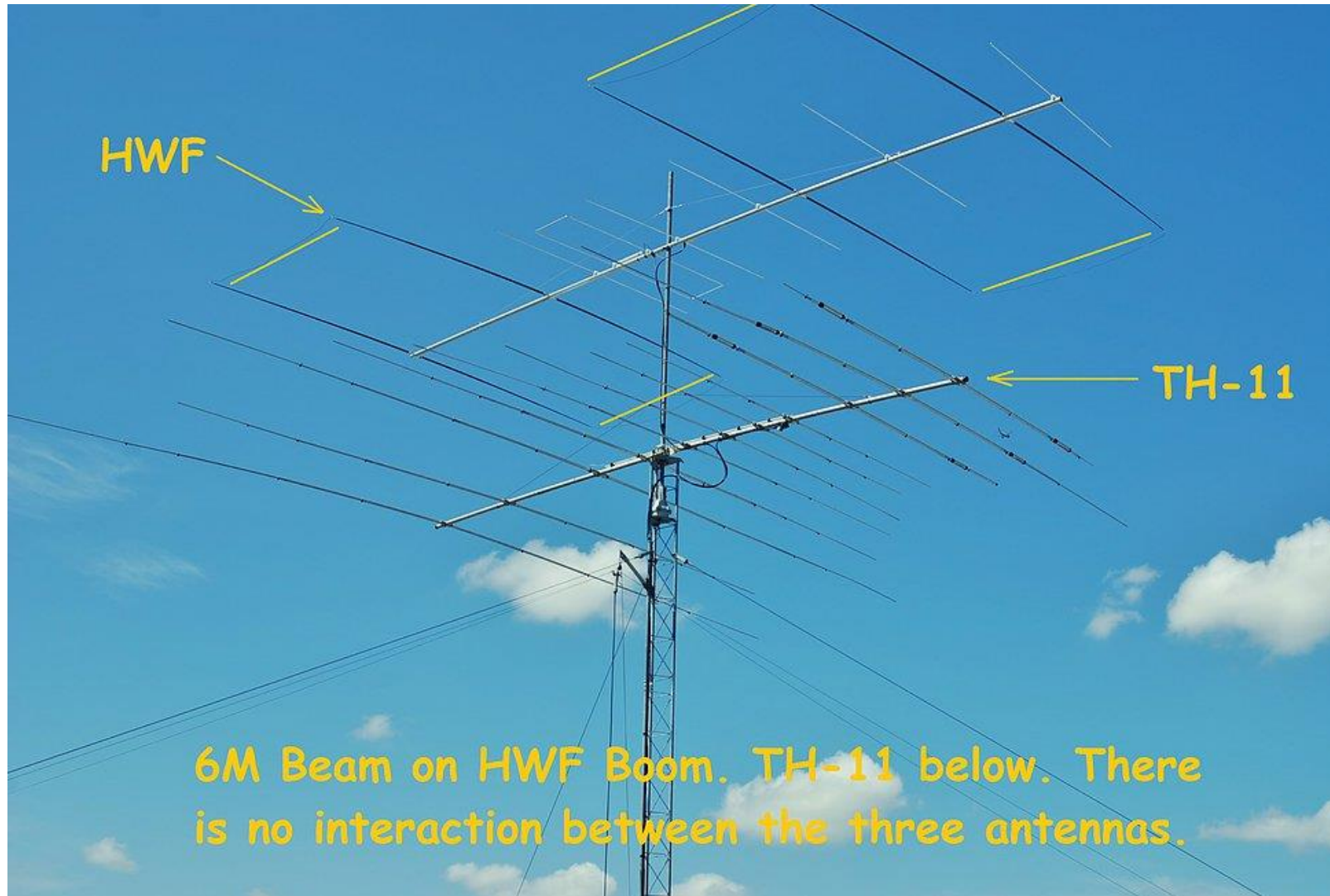

HWF Horizontal Waller Flag pictures PY2XB



More HWF photos >>>>>>>>

<http://nx4d10.wix.com/waller-flag#!page3/cee5>