



Handbook on Digital Terrestrial Television Broadcasting Networks and Systems Implementation

Edition of 2016



Handbook on Digital Terrestrial Television Broadcasting Networks and Systems Implementation

Edition of 2016

ITU-R



Editors' Foreword

In 2002, ITU published its first Handbook on digital terrestrial television under the title *Digital terrestrial television broadcasting in the VHF/UHF bands*¹ as guidance to engineers responsible for the implementation of digital terrestrial television broadcasting (DTTB). In this Handbook, new digital broadcasting technologies were explained in detail, for example a splendid description of the Discrete Cosine Transform (DCT) coding that is the basis of all past and present TV compression systems, as well as a very instructive chapter on signal power summation.

Most of that content are not repeated in this new Handbook on Digital Terrestrial Television Broadcasting Networks and Systems Implementation. Therefore, the version 1.01, which was published by ITU in the year 2002, has not lost value and should still be consulted.

Since 2002, DTTB has tremendously evolved, not only in technical but also in regulatory aspects. For example, at the turn of the century, MPEG had just started to develop the compression scheme MPEG-4, and HEVC was not known at all. In two sessions, in 2004 and 2006, the important ITU Regional Radiocommunication Conference RRC-06 was held in Geneva and agreed a new frequency plan for digital broadcasting in Region 1 (except Mongolia) and in Iran. For all UHF stations, the Conference decided that the transition period from analogue to digital broadcasting would take place by 15 June 2015. Today, majority of developed countries have already introduced digital TV broadcasting and have closed their analogue TV services. However, many developing countries have just started

Successive WRCs have identified new spectrum for the mobile service in the traditional UHF broadcasting bands. Consequently, spectrum for terrestrial TV broadcasting as well as for services ancillary to programme making or broadcasting (SAP/SAB) became scarcer within the existing UHF broadcasting bands. More spectrum efficient transmission and compression schemes can only partly compensate for that loss as new requirements for improved resolution, such as HDTV and UHD TV, demand significantly higher data rates. Also, new formats for multi-channel sound can need substantial amounts of transmitted data. So do the ever-increasing amount of metadata and access services.

Today, with the advent of broadband IP networks (wired and wireless), interactivity has become commonplace. Most modern TV sets are equipped with an interface for DSL or Wi-Fi in addition to the traditional antenna input for digital terrestrial, satellite and/or cable TV.

This new ITU Handbook, entitled *Digital Terrestrial Television Broadcasting Networks and Systems Implementation*, concentrates on these new developments during the last 15 years. In this context, it complements ITU-D Guidelines for the transition from analogue to digital broadcasting² which made use of technical, operational and procedural information from the ITU Radiocommunication Sector and directed itself primarily to the analogue-to-digital switchover in developing countries.

Numerous experts of ITU-R Working Party 6A (Terrestrial broadcasting delivery) and of the parent ITU-R Study Group 6 (Broadcasting service) have been involved in the development of this new Handbook. The names of these contributors are listed in the Acknowledgements section.

¹ **ITU-R** *DTTB Handbook – Digital terrestrial television broadcasting in the VHF/UHF bands V 1.01*, ref. <https://www.itu.int/pub/R-HDB-39>

² **ITU-D** *Guidelines for the transition from analogue to digital broadcasting*, ref. <https://www.itu.int/en/ITU-D/Regional-Presence/AsiaPacific/Documents/AtoDguidelinesV3.pdf>

However, one person must be mentioned here because of his outstanding dedication: most thanks go to the principal author, Professor Oleg Gofaizen (Ukraine), who led the process of writing this Handbook and who tirelessly acted towards its completion.

The Study Group 6 approved this new Handbook at its meeting on 28 October 2016.

The Core Editing Team Christoph Dosch, David Hemingway and Walid Sami
Geneva, October 2016

Acknowledgements

For the compilation of this Handbook, Working Party 6A established a special Rapporteur Group, which was chaired by Professor Oleg Gofaizen (Ukraine), who diligently worked over the years assembling numerous contributions into a draft Handbook. This draft was considered by WP6A in its meeting in January-February 2016. A Correspondence Group was formed with the task of finalizing the Handbook in time for the WP6A meeting in October 2016. The Correspondence Group was co-chaired by Christoph Dosch (former Chairman of Study Group 6 and currently Vice-Chairman of Study Group 6) and David Hemingway (BBC, Vice-Chairman of Working Party 6A), assisted by Walid Sami (EBU, Vice Chairman of Study Group 6 and Working Party 6A). Additional contributors joined this work.

A list of the experts who contributed to this Handbook is given below, to whom special thanks are due.

Name	Organization / Administration
Dr. Abdullah Saleh ALARAIMI	Oman
Dr. Pablo ANGUEIRA BUCETA	Spain
Dr. Vladimir BALYAR	Ukraine
Mr. Vittorio BARONCINI	Italy
Mr. Istvan BOZSOKI	ITU-D
Mr. Roger BUNCH	Australia
Mr. José Ramón CAMBLOR	Ministerio de Industria, Energía y Turismo, Spain
Mr. Perez DE LEMA	Spain
Mr. Christoph DOSCH	IRT
Dr. Charles EINOLF	CBS
Dr. Joseph FLAHERTY	USA
Prof. Oleg GOFAIZEN	Ukraine
Dr. David GUERRA PEREDA	University of the Basque Country
Mr. Jean-Jacques GUITOT	France
Mr. Pham HAI	ITU-R
Mr. David HEMINGWAY	BBC
Dr. Shuji HIRAKAWA	Japan
Mr. Klaus HUBER	LS Telcom
Mr. Mark JORDAN	Arqiva
Dr. Alina KARWOWSKA-LAMPARSKA	Poland
Dr. Alexandre KHOLOD	Switzerland
Ms. Kyung-Mee KIM	Korea
Ms. Lucia Luisa LA FRANCESCHINA	Rai Way SpA
Mr. Stephane MEBALEY EKOME	France
Dr. Alberto MORELLO	RAI
Mr. Amir Hassan NAFEZ	Iran
Mr. Akira NEGISHI	NHK
Mr. Yukihiro NISHIDA	Japan
Mr. Kyoungseok OH	Korea (TTA)
Mr. Larry OLSON	USA
Prof. PAN Changyong	Tsinghua University, China
Mr. Rolly PURNOMO	Indonesia

Name	Organization / Administration
Mr. Ari REFIK	TDF
Dr. Walid SAMI	EBU
Mr. Eli SOFER	Israel
Mr. Supatrasit SUANSOOK	NBTC, Thailand
Ms. Sato TELEMI	IRT
Ms. Anne-Lise THIEBLEMONT	Qualcomm
Mr. Kengo TSUDA	NHK
Mr. Aljo VAN DIJKEN	Netherlands
Dr. Manuel María VELEZ ELORD	Spain
Mr. Tobias VIERACKER	IRT
Dr. David WOOD	EBU
Ms. Norafidah YOSUF	Malaysia
Mr. Juan ZAPATA	Colombia

Additionally, great thanks are due to all the other members of Study Group 6, past and present, who have contributed – directly and indirectly – to this Handbook.

Special thanks must go to Prof. Marc Krivocheev (Russian Federation), Honorary Chairman of SG6, for his continued guidance throughout the drafting process.

Disclaimer

The opinions expressed in this publication are those of the editors and authors and do not necessarily represent the views of the ITU. This publication is only intended for informational purposes only. Whilst every effort had been undertaken to provide clear and correct information, neither ITU nor the contributors to this Handbook can be made responsible for any decision taken or any investment made based on this Handbook.

PREFACE – WHAT THE HANDBOOK IS ALL ABOUT

The aim of the Handbook is to provide assistance in technical and service issues such as networks and systems, audiovisual quality and quality of transmission as well as on other issues of interest for the introduction of digital terrestrial TV broadcasting (from multimedia systems to UHDTV) in different countries. The Handbook takes into account progress and convergence of technologies, different environments for production, primary and secondary distribution of broadcast programs as well as experiences in providing quality of service for DTTB.

In more detail, the Handbook considers:

- 1) Technical aspects on the introduction of digital terrestrial and multimedia broadcasting.
- 2) Information on standardized broadcasting systems in digital terrestrial and multimedia broadcasting networks, and some guidance on their implementation.
- 3) References to normative documents (standards, technical specifications, reports, recommendations and other documents) that are important with respect to baseband (audio, video data) and transmission quality, as well as to DTTB services including interactive TV and access services.
- 4) The use of DTTB systems in electronic news gathering and contribution of audio-visual content.

The content of the Handbook is structured as follows:

PART 1 – NETWORKING ASPECTS OF DIGITAL TV BROADCASTING

Chapter 1 “General Aspects of digital TV broadcasting” highlights general aspects, concepts and trends for technologies of digital TV broadcasting. The Chapter is useful for definition of general strategies of development and implementation of digital terrestrial television and multimedia systems and technologies.

Chapter 2 “Strategies for DTTB introduction” provides concrete strategies for the introduction of digital terrestrial television, including information on related distribution schemes such as cable TV or satellite broadcasting, on the cost for the implementation of terrestrial broadcasting networks, on spectrum sharing with other radio services, etc.

Chapter 3 “Requirements for the implementation of digital terrestrial television broadcasting networks” describes user, service and spectrum requirements to terrestrial broadcasting networks (user functionality, parameters related to user requirements, set of services, elements of quality of experience, frequency usage, etc.).

Chapter 4 “Broadcast network planning” defines broadcast network architectures and basic aspects of terrestrial broadcast networks (network model, influence of parameter selection of digital terrestrial television broadcasting system on network architecture, network structure for different frequency usage modes and others).

Chapter 5 “Sharing and protection” specifically deals with interference from other services and systems to DTTB as well as the interference DTTB may cause to other services in band or in adjacent bands.

Chapter 6 “Cross-border coordination” provides information on frequency assignments and frequency allotments used for frequency planning of broadcast network as well as on coordination procedures in terrestrial networks and describes basic parameters, procedures and approaches that are used for the planning of terrestrial broadcasting networks.

Chapter 7 “Quality of service for broadcast television” contains guidelines on the end-to-end quality considerations at the radio and intermediate frequency level. For baseband quality considerations see Chapter 12, for requirements on audiovisual data-rates see Chapter 3.

Chapter 8 “Satellite assistance” indicates how satellites can be used to feed and support terrestrial networks for providing television and broadcast multimedia services.

PART 2 – SYSTEM ASPECTS OF DIGITAL TV BROADCASTING

*Chapter 9 “**Systems for digital terrestrial television broadcasting**”* contains structured information on architectural models, key technologies, physical and link layers, system performance and link budget for digital terrestrial television broadcasting systems (ATSC, ISDB-T, DTMB, DVB-T, DVB-T2) as well as on so-called multimedia broadcasting systems such as T-DMB, ISDB-T, DVB-H, ATSC-M/H or DVB-T2 Lite. Furthermore, the system layer elements of digital broadcasting systems are presented (service multiplex methods, service information, protocol stack, data transmission techniques and services over digital terrestrial and multimedia systems, transport interfaces, etc.).

*Chapter 10 “**Interactivity and collaboration between DTTB and non-broadcasting systems**”* covers interactive television technologies via terrestrial environment by providing information on interactivity aspects, system models, IBB systems (HbbTV, Hybridcast and others) and terrestrial interaction channel implementations and depicts general trends and approaches to the interlinking of broadcast and non-broadcast (particularly broadband) technologies with respect to the application, network, and service layers.

*Chapter 11 “**Conditional access and content protection in digital television broadcasting**”* contains general definitions and approaches for the implementation of conditional access and the content protection in digital television broadcasting.

*Chapter 12 “**Quality of the baseband signal**”* defines quality of service for broadcast television applications and provides, in particular, information on quality definitions, quality requirements, quality estimation/assessment during signal compression and transmission for various examples of television systems.

*Chapter 13 “**Digital TV receivers**”* deals with the requirements for consumer-type DTTB receivers including considerations on middleware and Hybrid Broadcast-Broadband functionality.

*Chapter 14 “**Accessibility aspects**”* describes access systems in DTTB that are intended for people with disabilities and other groups with special needs.

PART 3 – CONTRIBUTION AND ENG ASPECTS FOR DIGITAL PROGRAMME PRODUCTION

*Chapter 15 “**Contribution and news-gathering systems**”* deals with issues on classification, concepts, frequency and user requirements for the outside production and news-gathering of SDTV, HDTV, or UHD TV and describes some transmission standards for their contribution links.

TABLE OF CONTENTS

	<i>Page</i>
PART 1 – NETWORK ASPECTS	1
CHAPTER 1 – General aspects of digital TV broadcasting.....	3
1.1 Recognizing trends in DTTB	3
1.2 Broadcasting relies on interoperability.....	3
1.3 DTTB in the media environment.....	4
1.4 The continuous development of DTTB.....	4
1.5 The ITU DTTB model.....	5
CHAPTER 2 – Strategies for DTTB introduction.....	7
2.1 Factors for consideration when introducing DTTB.....	7
2.2 Network costs and configuration.....	10
2.3 DTTB introduction combining different network configurations	11
2.4 Sharing of spectrum by broadcast and non-broadcast services	11
2.5 Conclusion.....	11
CHAPTER 3 – Requirements for the implementation of digital terrestrial television broadcasting networks	13
3.1 Introduction	13
3.2 User and service requirements.....	13
3.3 Spectrum requirements.....	19
3.4 Receiver related requirements	20
CHAPTER 4 – Broadcast network planning.....	23
4.1 Digital terrestrial television networks	23
4.2 Basic terms and definitions	23
4.3 DTTB network considerations: physical layer and parameters	28
4.4 Broadcast network planning	29
4.5 Broadcast network coverage	31
4.6 Network planning in MFN	41
4.7 Network planning in SFN.....	45
Annex 1 to Chapter 4 – Reference Planning Configurations and Reference Networks in the GE06 Agreement	52
Annex 2 to Chapter 4 – Example Implementation Scenarios.....	60

CHAPTER 5 – Sharing and Protection	77
5.1 Introduction	77
5.2 Categories of Interference	77
5.3 Sources for general technical characteristics and criteria for sharing	78
5.4 Reference sources related to compatibility between DTTB and the Mobile service	79
5.5 Reference sources related to other compatibility issues involving DTTB	80
5.6 Indications about actual sharing between DTTB and SAB/SAP	80
CHAPTER 6 – Cross-border coordination.....	81
6.1 Coordination procedures	81
6.2 Coordination examples.....	83
CHAPTER 7 – Quality of service for broadcast television.....	91
7.1 Overview: The DTTB chain.....	91
7.2 Examples of Specifications to enable Quality of Service.....	92
7.3 Measurements for monitoring QoS	93
7.4 Examples for transmission quality in digital television.....	94
7.5 Redundancy as a means of maintaining QoS	94
CHAPTER 8 – Satellite assistance.....	97
8.1 Introduction	97
8.2 Satellites as feeder-links for terrestrial television broadcasting networks.....	97
8.3 Using satellites as IP return channels for interactive television	98
8.4 Joint usage of the terrestrial and the satellite broadcasting	98
PART 2 – SYSTEM ASPECTS	101
CHAPTER 9 – Systems for digital terrestrial television broadcasting.....	103
9.1 Broadcast system technologies.....	103
9.2 Digital terrestrial television and multimedia transmission systems	130
9.3 ATSC.....	132
9.4 DVB-T and DVB-T2.....	143
9.5 ISDB-T	186
9.6 DTMB and DTMB-A.....	202
9.7 T-DMB	216
9.8 RAVIS	220
9.9 MediaFLO	226

CHAPTER 10 – Interactivity and collaboration between DTTB and non-broadcasting systems	235
10.1 General aspects and opportunities of collaboration.....	235
10.2 Collaboration at the service layer	235
10.3 Technical commonalities.....	236
10.4 Collaboration at the network level	237
10.5 Detailed discussion on interactive television	238
CHAPTER 11 – Conditional access and content protection in digital television broadcasting	243
11.1 General aspects.....	243
11.2 Approaches to CAS implementation	244
11.3 Content Protection and Copy Management.....	247
CHAPTER 12 – Quality of the baseband signal	249
12.1 Introduction	249
12.2 Objective quality estimation for compression systems in digital television.....	250
12.3 Subjective quality estimation for compression systems in digital television	252
CHAPTER 13 – Digital TV receivers	255
13.1 General aspects for DTTB receivers	255
13.2 Requirements for DTTB receivers	255
13.3 Middleware for DTV receivers	259
13.4 Integrated Broadcast-Broadband functionality.....	260
CHAPTER 14 – Accessibility aspects.....	263
14.1 ITU and the need for access services	263
14.2 Access services relevant to TV broadcasting	264
14.3 Receiver-processed versus broadcast-based access services.....	264
14.4 The use of subtitles/captions	265
14.5 The special importance of IBB (Integrated broadcast-broadband) systems.....	265
14.6 Production of access services – some aspects	268
14.7 Conclusions	268

	<i>Page</i>
PART 3 – Contribution and eng aspects for digital programme production	271
CHAPTER 15 – Contribution and news gathering systems	273
15.1 Introduction	273
15.2 Terrestrial News Gathering and Contribution	276
List of Abbreviations	295

PART 1

NETWORK ASPECTS

Introduction to Part 1

The most dynamic and technically complex environment of TV content distribution is digital terrestrial television broadcasting (DTTB). Traditionally, TV broadcasting served stationary receivers at home. Today's users require information, infotainment and entertainment anywhere, at any time and on any device, if possible interactively and at the highest possible service quality. Modern broadcasting concepts try to cope with these demands that can only be satisfied by digital technologies. Digital terrestrial broadcasting can be designed to work with roof-top antennas but also with small antennas built into portable devices and for mobile reception. In case of a disaster, devices that do not depend on larger antenna installations are more likely to continue serving the public than, for example, satellite TV which relies on parabolic dish antennas.

The service areas of terrestrial broadcasting plans are often interference-limited. The interference comes from neighbouring broadcasting transmitters in the same and in adjacent channels, and from transmitters in other services. Terrestrial broadcasting needs careful frequency planning in order to make optimum use of the available frequency spectrum.

The factors mentioned above need to be considered when designing and building terrestrial television broadcasting networks. The information given in Part 1 should enable administrations and broadcasters, when switching from analogue to digital terrestrial broadcasting, or that are in the process of introducing digital terrestrial television broadcasting, to choose the most effective way of implementation in accordance with their individual requirements, and to take as much advantage as possible from the digital technologies in terms of spectrum resources, signal quality and the cost of introduction. Part 1 of this Handbook explores these considerations.

CHAPTER 1

General aspects of digital TV broadcasting

Digital broadcasting is a broadcast technology based on the transmission of audiovisual media information by bit streams. A broadcast signal is composed of video, audio and also includes data services such as teletext, subtitles (closed captions) or an EPG. In addition, descriptive and technical metadata are transmitted for programme identification and receiver configuration (e.g. information on the broadcast station, the applied video and audio compression systems, on the sound channel arrangement or on control data for interactivity, aspect ratio and numerous others). Furthermore, access services such as audio-description or a sign-language video can be incorporated within the broadcasting multiplex signal. Modern broadcasting makes use of a series of technologies which, together, allow for the creation of the broadcasting signal and its delivery to the end-users.³

1.1 Recognizing trends in DTTB

Media technology continues to evolve in reaction to changing consumer needs and desires, and through research and development. We need to respect and correlate these two elements if we are to serve the public [1.1].

What the consumer finds attractive enough to buy depends on a range of factors. These begin with the kinds of content made available, continue with the absolute cost, the user's income, the user-friendliness of the equipment and of the services (make it simple for the end-users!), and include complements to TV broadcasting – other delivery means which can make use of the equipment and can support it.

1.2 Broadcasting relies on interoperability

One of the important concepts of broadcasting is interoperability. Different systems or system elements can interlink provided they are interoperable, i.e. they make use of agreed interfaces. Digital TV systems thus have two basic components:

- Generic elements: These are elements which apply whatever the delivery system is (terrestrial, cable, satellite, etc.). They can benefit from common hardware and software, and make the construction of multi-delivery system receivers easier and cheaper. Video and audio compression systems are a prime example of such generic technologies;
- Application-specific elements: These elements are necessarily different, for example modulators and demodulators for satellite and terrestrial television.

Another requirement for broadcasting is the capability to deliver, to the costumers, media information at different quality levels. An example is the transition phase from standard quality TV to HDTV. Such HDTV signals may use newer, more spectrum efficient but incompatible coding schemes. They could be simultaneously broadcasted with a conventional-quality version of the programme, to serve both conventional and HDTV receivers at the same time.

This is not the only scenario for future HDTV broadcasting, but it is a reasonable assumption, because of the continued evolution of coding techniques.

³ Traditionally, ITU-R distinguished in its Recommendations between television and multimedia broadcasting. This was driven by the fact that broadcasting to portable & mobile devices should be characterised by low data rates and consequently lower quality video and audio than TV intended for stationary reception. Today, the throughput of telecommunications networks has increased and all handsets are capable of displaying high-quality audio-visual content. Thus, the need to distinguish between television and multimedia broadcasting is fading.

1.3 DTTB in the media environment

DTTB services are introduced in parallel with other means of delivery such as satellite-TV, cable-TV or IPTV (online TV on managed broadband networks) and streaming services on the open Internet (often called OTT (Over-the-Top) TV or online TV). Satellite and cable TV typically provide more television channels than DTTB owing to the larger channel bandwidth (satellite case) and larger frequency spectrum for TV on cable. In theory, with IPTV or streaming over the open Internet, the number of TV programmes available is unlimited. Despite its lower capacity, DTTB is generally seen as most important for the future of TV broadcasting. The **Terrestrial Television Initiative Memorandum of Understanding (issued by FOBTv) [1.3] states:**

“Terrestrial broadcasting is uniquely important because it is wireless (supports receivers that can move), infinitely scalable (point-to-multipoint and one-to-many architecture), local (capable of delivering geographically local content), timely (provides real time and non-real time delivery of content) and flexible (supports free-to-air and subscription services). The attribute of wireless delivery of media content to a potentially unlimited number of receivers makes terrestrial broadcasting a vital technology all over the world. Broadcasting is, in fact, the most spectrum-efficient wireless delivery means for popular real-time and file-based media content”.

Where appropriate, e.g. with respect to interactive services, this Handbook will also make reference to IP connections.

1.4 The continuous development of DTTB

Regulators, spectrum managers and broadcasters are faced with the question of how to continue and extend the delivery of their existing broadcasting services and how to introduce new broadcasting services in a frequency-efficient and cost-effective way, taking account of, *inter alia*, the following issues:

- local market requirements;
- existing transmission networks and receivers;
- alternative means of content delivery, including IP broadband, via mobile, fixed and satellite networks;
- regional and international regulatory requirements regarding the use of the frequency spectrum and, in particular, the impact of decisions adopted at the WRC-07, WRC-12 and WRC-15 with respect to the co-allocation of the 800 MHz and 700 MHz bands to the Mobile Service and their identification for IMT;
- existing broadcasting transmission standards and future developments;
- demands on spectrum from services other than broadcasting (for example for PMSE).

Developments in terrestrial broadcasting have to take into account the production of higher quality content as well as the offer of new and additional information and interactive services, all resulting in higher transmission data-rates.

Digital broadcasting networks have to constantly cope with changing media environments and new requirements, due to:

- demand for more services of higher technical quality and with improved coverage;
- new technology leading to improved efficiency in the use of the spectrum;
- changing regulations on the use of the spectrum;
- a wider range of consumer devices, ranging from large screens and multi-channel audio equipment to handheld devices.

Furthermore, television broadcasting development is inspired by processes such as:

- a) In an increasing number of countries, all TV services will be offered in HD quality.
- b) New formats, such as UHD TV and 3DTV, Companion Screens, interactive television (e.g. Integrated Broadcast-Broadband platforms) and others are expected to be introduced in the terrestrial environment in the near future.

- c) Screen sizes for home viewing will increase (diameters of more than 50 inches are already common) and the use of 1080p/50 or 1080p/60 formats has already started to be implemented in various DTTB networks. On the other hand, there is also a clear trend to mobile and portable reception on smaller-size screens.
- d) UHDTV will be implemented in some countries, making use of advanced compression systems such as HEVC⁴.
- e) The new, twice as efficient compression system called HEVC became available in 2015. The system has about two times higher coding efficiency than MPEG-4/AVC. Initially it may be used with new UHDTV services but it is also likely that future HDTV services in DTTB will use this video compression system.
- f) Second generation transmission systems will be implemented in more and more countries to provide sufficient capacity in the DTTB networks in order to:
- deliver an attractive HDTV service package;
 - compensate for the reduction of the UHF TV band, due to the introduction of IMT in parts of the broadcasting spectrum.
- g) The Mobile Television (MTV) market prospective is variable. Many systems exist, either as dedicated MTV system, or as part of a DTTB transmission family of standards. In addition, multimedia services via mobile communication networks (3G and 4G) show very high growth figures.

1.5 The ITU DTTB model

In 1995, ITU-R Task Group 11/3 started the publication of a guide to Digital Terrestrial Television Broadcasting in the VHF/UHF Bands. An updated version was published as Document 11-3/3 in January 1996 [1.4]. This work established the initial design of the DTTB system model which is summarized in Figure 1.1.

FIGURE 1.1
DTV System Model⁵

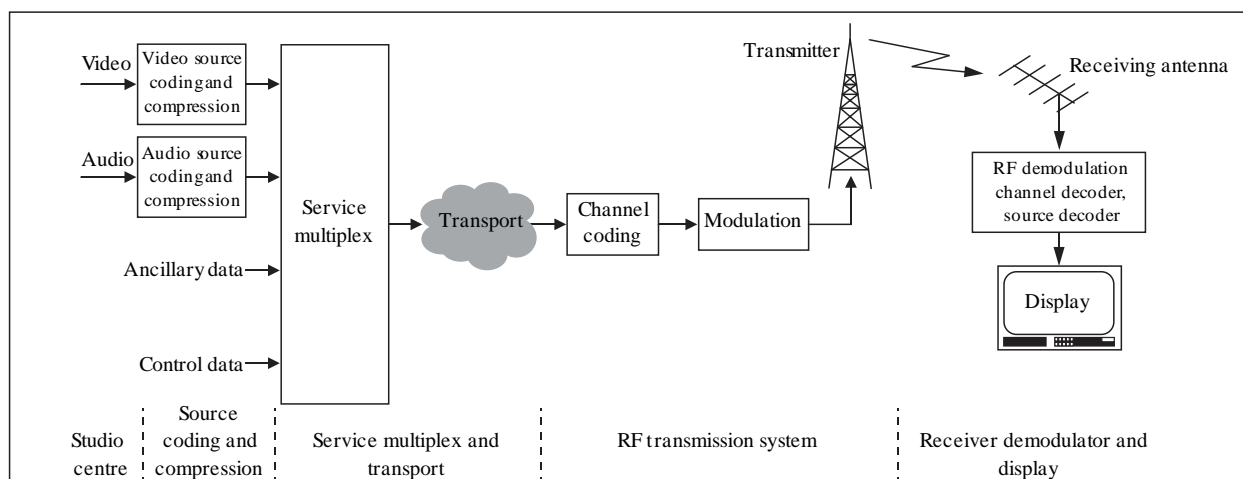

DTTB-01-01

⁴ In this Handbook, HEVC is used synonymously with MPEG-H and ITU-T H.265.

⁵ Note that with the advent of advanced 2nd generation transmission and modulations systems an additional block is to introduced between service multiplex and transport, the so-called Gateway (as explained in Chapter 7).

The model is divided into four subsystems as shown in the Figure:

- source coding and compression;
- service multiplex and transport;
- the physical layer, which comprises a) RF channel coding, modulation and propagation, and b) the receiving installation including demodulator, channel decoder and content decompression.

In parallel, planning factors (including both the transmission and receiver planning factors) and implementation strategies needs to be considered.

“Source coding” refers to bit-rate reduction methods also known as data compression and error protection techniques that are appropriate for application to the video, audio, and ancillary digital data streams. “Ancillary data” includes control data, including conditional access control, and data associated with the audio programme and video services such as closed captioning. Ancillary data can also refer to independent programme and data services.

The “service multiplex and transport” refers to the means of dividing the digital data stream into “packets” of information, the means of uniquely identifying each packet or packet type, and the appropriate means of multiplexing the video data stream packets, the audio data stream packets, and the ancillary data stream packets into a single data stream. Interoperability or harmonization between digital media such as terrestrial broadcasting, cable distribution, satellite distribution, recording media, and computer interfaces must be a prime consideration in developing an appropriate transport mechanism.

The “physical layer” refers to the means of using the digital data stream information to modulate the transmitted signal and encompasses the so-called channel coding, i.e. the forward error-protection to protect the broadcast signal against incorrectly decoded bits.

“Planning factors and implementation strategies” include discussions of strategies appropriate for the introduction and implementation of digital terrestrial television broadcast service. The plans for any such strategies must recognize the interference characteristics of the over-the-air media and the practical limitations imposed at the receiver.

Chapter 4 refers in detail to the physical layer and planning factors as well as to the strategic planning aspects and the service multiplex and transport.

Bibliography to Chapter 1

- [1.1] **Wood D**, *European strategies, approaches, and projects for new media* / David Wood // SP: IC (20), October-November 2005. No. 9-10. P. 789-800
- [1.2] **ITU-D**, *Trends in broadcasting: An overview of developments*, February 2013, ref. <https://www.itu.int/en/ITU-D/Technology/Documents/Broadcasting/TrendsinBroadcasting.pdf>
- [1.3] **FOBTV**, Future of Broadcast Terrestrial Television Initiative Memorandum of Understanding: ref: www.fobtv.org
- [1.4] **ITU-R** Doc. 11-3/3 – *A Guide to Digital Terrestrial Television Broadcasting in the VHF/UHF Bands*, January 1996. <http://happy.emu.id.au/lab/tut/dttb/dttbtuti.htm> A later document (April 1996), 11/4-1, is available at <http://www.itu.int/itudoc/itu-r/archives/rsg/1996-97/rsg11/33390.html> for TIES users only.

CHAPTER 2

Strategies for DTTB introduction

Provision of television services and therefore, the introduction of digital terrestrial television broadcasting (DTTB), is a highly political issue, and also likely to be highly regulated. Comprehensive preparation, including the necessary regulatory measures to satisfy stakeholders and the public interest, along with their respective impact assessments, is an essential prerequisite for the introduction of DTTB.

This section provides a brief overview of the political and regulatory options associated with the introduction of DTTB services. More detailed information can be found in parts 2 and 3 of the ITU-D Handbook [2.1].

2.1 Factors for consideration when introducing DTTB

2.1.1 Impact of the current market share of analogue terrestrial television

If terrestrial (analogue) television is the dominant TV platform in a market, it can be reasonably envisaged that DTTB, in an attempt to replicate that service, will be introduced based on roof-top reception. In order for the user to re-use existing receiving antennas, it may therefore be advantageous to re-use the existing transmitter sites as far as possible.

This leads however to a non-optimized DTTB plan since the technical requirements of DTTB are different from those of analogue TV. In general, there is a need to find the right balance between optimized and efficient networks, and incurring additional costs. The majority of networks in countries which have introduced DTTB have relied to a large extent on re-using the existing infrastructure already used for analogue TV.

2.1.2 Reasons for choosing DTTB

In general the introduction of DTTB is politically driven, even if it is in part in response to commercial pressures. Commercial pressures include provision of a larger number of TV programmes (including from new programme providers) and releasing spectrum for other uses (e.g. mobile broadband services).

The strategic motivations for choosing DTTB may include of the following:

- DTTB is nationally safe as a distribution means, under national control, compared to “extra-nationally controlled” satellite distribution, ensuring that national media regulation can be imposed and not by-passed.
- DTTB is easy to use, simple to install and to use, in particular with TV sets having built-in tuners and using small indoor or outdoor antennas.
- DTTB is cost effective for citizens as it can offer free-to-air (as well as pay) access to content at very low installation cost, hence ensuring competition between distribution platforms. The cost of the receiver, in a set top box or inside a TV set, is low.
- DTTB allows broadcasters to provide content to large audiences nationally or sub-nationally at a constant cost. The cost of distribution rights with a DTTB limited coverage might also be reduced compared to large satellite coverage. Terrestrial broadcasting is a very efficient means to provide all the population with information in normal and emergency situations, along with education and entertainment.
- DTTB is a business enabler, offering the opportunity for local and national advertising, more targeted on a terrestrial network than on a satellite network. It can also enable potential job creation that can be triggered by the development of local and national content production.

- DTTB is innovative and is, in general, very spectrum efficient thanks to the use of advanced video compression and modulation techniques, and the potential for SFNs. HDTV and even UHD TV can be distributed terrestrially. Interactive broadcast-broadband systems (such as HbbTV or Hybridcast, etc.) offer new user experiences. In-home distribution of DTTB through Wi-Fi is possible with existing and cost-efficient technologies.
- DTTB is successful: in 2015, 118 million households were receiving and watching DTTB in Europe, providing more than 2000 TV channels.

2.1.3 Infrastructure sharing

In some countries, sharing of transmitter sites has been found to be advantageous. In this model, several operators may choose to pool their existing sites and build transmitter networks based on some or all of those sites, which may reduce the high investment cost for each operator of acquiring and building new transmitter sites. This approach has been adopted in Germany, for example. The number of multiplex layers which can share infrastructure has a dramatic impact on the overall deployment costs.

In addition, infrastructure sharing will reduce the complexity of network planning, especially when all the networks are sharing the same antenna system.

In some countries, infrastructure sharing was not applied for the analogue television system. The analogue television transmitters of each broadcaster were located at different location within the same service area. In such case, some viewers were required to install more than one receiving antenna pointing into the different directions to be able to receive all programmes. Therefore, infrastructure sharing for DTTB is also like to be beneficial for the viewers.

Any decisions on infrastructure sharing must, in the end, be made on a national basis.

2.1.4 DTTB as a competition enabler

If cable and satellite platforms already serve viewers in a market, DTTB will have to compete against those. Regulation may play a key role here, in order to enable and establish competition between the different platforms.

If the terrestrial network plays a minority role in the market, regulators have to be aware that the other platforms may put pressure on the program service providers who are considering a potential service launch on DTTB. In this case, it may be difficult to establish a new DTTB platform on a pure market basis. Some regulation may be a prerequisite to allow the successful deployment of DTTB.

For both viewers and broadcast service providers, there is in many countries a situation of near monopoly for program distribution. This carries a risk of market distortion issues such as artificially inflated prices.

It should be noted that for satellite distribution, it is in general not possible to limit the coverage footprint according to political borders. In most cases, the only solutions for rights issues which arise are to encrypt the signal – with all the implications that brings – or to negotiate program rights beyond the extent of the desired market. In the former case, the viewer has to buy a set-top box with integrated conditional access, and the associated smart card needs to be provided. These both imply additional cost for the viewer, the service provider or both. For example, in France a set-top box for satellite reception is five times more expensive than a set-top box for DTTB.

Cable distribution generally results in vertical proprietary markets which may be more or less user-friendly, since a proprietary set-top box has to be purchased in most cases, and the available channels are encrypted.

2.1.5 The benefits of industry cooperation for successful DTTB introduction

In general, for basic functionalities, there is no difficulty for a large majority of receivers to be compliant with broadcast DTTB signals. However, for specific features of a DTTB standard, which are implemented at the price of additional development costs, it is less clear that these feature will be implemented correctly in all equipment available on the market, especially if the introduction of set-top boxes is purely market driven. Interoperability can be encouraged by involving all stakeholders (broadcasters, infrastructure providers, consumer electronics manufacturers, regulators etc.) in a strong platform brand, with trademark licensing for

receiver equipment, as was done, for example, in the United Kingdom with the Freeview branding for DTTB. If the specification requirements are very demanding, it may be worthwhile transferring the responsibility for the specification and ensuring the interoperability to a coordination board of stakeholders and industry. The creation of a “task force” including all stakeholders such as regulators, media authority, industry, broadcast networks operators, antenna installers and program providers is highly recommended.

2.1.6 Licence aspects – multiplex awarding or program licence awarding

Another aspect which is material in determining the progress of the DTTB platform is the composition of the multiplexes. In some countries, multiplexes were allocated directly to program providers. This can simplify the regulatory regime and can also allow better statistical multiplexing since the operator can optimize the content and the data rate at the same time.

The drawback for such an approach is that only important established program providers may have easy access to multiplexes, which could in turn decrease the potential for new services and new operators to emerge. Conversely, with licences awarded by program, the regulatory difficulty is higher: the data rate, signalling and associated data all have to be allocated in a fair manner.

A third model is to license multiplexes to businesses established purely to operate those multiplexes. They act as a “middleman” between program providers and broadcast network operators. They contract with the network operators for the transmission infrastructure, and sell capacity to interested program providers. It may be necessary to regulate the way in which the multiplex operator allocates capacity and operates any statistical multiplexing to ensure all program providers are treated equitably.

Any analogue-to-digital switchover process can bring advantages to the broadcasting industry, but these will vary between countries depending on prevailing market conditions. As an example, in France the analogue switch-off could only be achieved, with the licensing of an additional program at the introduction of DTTB and another at the end of switch-over. In the United Kingdom, by contrast, the switchover process allowed the use of higher transmission powers and higher transmission modes, increasing capacity and allowing the multiplex operators to add more program services.

2.1.7 The switch-over process

The switchover from analogue to digital broadcasting is a crucial phase for the introduction of DTTB. In general, two trends can be observed for the switch-over:

- A longer simulcast may be chosen in order to allow a smooth transition for the citizen.
- A shorter simulcast may allow more efficient and timely use of spectrum resources.

In some cases, after the switch-on of digital terrestrial services in highly populated areas, there will be a quick upgrade of domestic installations and consequent high success of DTTB services. At the same time, due to shortage of spectrum resources it is likely that enhancing the network (in terms of number of programmes, but also in the area covered) would not be possible without the release of spectrum occupied by analogue television services. Therefore, there can be pressure to advance the analogue switch-off date.

One of the drawbacks of a longer simulcast is the additional costs associated with a double transmission and the fact that analogue television has to be protected from interference during the transition period. In general, the analogue reception can rely on many gap fillers which may have to be modified to free spectrum for DTTB. This is only obtained at the price of high re-engineering costs. In France, for example, the re-engineering of these gap fillers was funded by a tax on the new entrants.

Report ITU-R BT.2140 [2.2] contains extensive information about the switch-over process in many countries of the world, and includes guidance on the principal problems and possible solutions associated with the transition process.

Further information on the transition from analogue to digital broadcasting is given in the ITU-D Handbook [2.1].

2.1.8 Access services and ancillary services

One of the advantages DTTB has over analogue television broadcasting is the increased capability of providing access services. These include:

- Second (and further) language soundtracks;
- Improved subtitling, including in multiple languages;
- Audio description;
- Sign language interpretation.

Each of these can provide an important service to viewers who are normally excluded from television audiences, but each requires additional data capacity which needs to be planned for when establishing multiplex data budgets. The means of accessing these services needs to be considered (for example, through simple selection on a remote control), but this functionality needs to be considered when specifying set-top boxes.

In addition to these access services, broadcasters may also wish to provide other (ancillary) services which would also require additional data capacity, such as commentary-free soundtracks for sporting events, or data services.

More information on aspects of accessibility in DTTB systems can be found in Chapter 14 of this Handbook.

2.1.9 Other considerations

Successful introduction of DTTB requires a suitable regulatory environment that incentivizes commercial television deployment. If digital terrestrial television is primarily aimed at the secondary or tertiary TV sets, this may represent a difficulty. Commercial television is usually funded by advertisement, the level of which is directly linked to market share. However, in many countries the market share for audience is only measured for the primary TV set. This has to be taken into account when introducing digital terrestrial television into a market with dominant satellite and cable platforms, as, for example, in Germany.

In conclusion, it remains a political decision to encourage competition between distribution platforms or to foster the deployment of DTTB. But it should be noted that in almost all countries that have launched DTTB it was a politically dominated decision.

2.2 Network costs and configuration

One of the possible incentives for incumbents to switch over to DTTB is reduced network cost.

For analogue television, there was no possibility of synchronizing two transmitters on the same frequency. Each high power transmitter had to be complemented by low power transmitters (gap fillers) on other frequencies.

For DTTB operation, Single Frequency Networks (SFN) can be used. They can improve the coverage beyond that obtained by the transmitters operating individually without using additional transmitter and spectrum resources. For example in Germany, all the gap fillers were switched off when the switch-over was completed. However, where fixed rooftop reception is dominant, users of the gap-fillers might need to replace or repoint their existing antennas.

The extent of the area that can be covered by an SFN depends critically on the chosen variant of DTTB. As a general rule, the more robust the variant is, the less data can be transported, but the larger the SFN can be. The size of the guard interval is also an important factor. In Germany, a rather robust variant was chosen with a large guard interval (16-QAM 2/3 guard interval 1/4) in order to allow for extensive SFNs. In France, a variant of high capacity with a small guard interval (64-QAM 2/3 Guard Interval 1/32) was chosen. This decreases the possibility of large area SFNs.

The maximum desirable size of an SFN is also determined by the editorial areas which it is desired to cover. As all transmitters in an SFN must carry identical data streams, an SFN cannot extend beyond the smallest editorial area of the programs carried.

Nevertheless, an SFN may in theory be deployed over any arbitrarily large area provided that the network is dense enough, considering the chosen robustness and guard interval. However, where broadcast network operators are trying to reduce their network deployment costs, the cost implications of a denser network need to be carefully considered.

One additional factor that leads to considerable network costs is the number of layers to be provided, especially if they were not part of the original network plan (for example, those planned at RRC-06). Of course, some evolution of the plan is possible, but any desire to increase the number of layers will inevitably lead to more cellular networks (because of the need to protect services in adjacent areas) which come with an increased cost.

2.3 DTTB introduction combining different network configurations

In many countries, DTTB is the main Free to Air distribution path but the infrastructure is very expensive to deploy. While it may be an obligation for public broadcasters to cover an entire country, for commercial channels the market decides on the extent of deployment (with regulators maybe specifying a minimum required coverage).

From a purely commercial point of view, it may be too expensive to cover 100% of a country's area or population. Nationwide coverage may be motivated by regulatory incentives: e.g. awarding of licenses under the conditions that a minimum coverage is achieved, or services may be given some priority in cable distribution networks under the conditions that it is locally receivable by DTTB.

In France, for example, the 5% of population not served by DTTB rely on a satellite platform, which leads to much higher costs for the rural population, as the cost of satellite receiving equipment is at least five times higher than for DTTB.

2.4 Sharing of spectrum by broadcast and non-broadcast services

When planning DTTB deployment, some consideration must be given to the possible coexistence scenarios of non-broadcast services with broadcasting services. In Europe, as distinct from the USA, the digital dividend was only addressed after the introduction of DTTB with several disadvantageous consequences:

- Existing receivers face severe interferences if no adequate measures are taken (so called “mitigation techniques”). These mitigation techniques have their drawbacks which may outweigh the benefits of using a lower frequency band. Appropriate receiver specifications, such as the dynamic range and adjacent channel protection ratios have to be (re-)defined to cope with the presence of non-broadcast services in the designed frequency range of the receiver.
- Significant effort and cost are required to re-plan existing networks (including possible requirements for international coordination) and to re-engineer existing network infrastructure.
- Reduction in opportunity for other users of “interleaved” spectrum. The spectrum between DTTB transmissions are already used in many countries by services ancillary to broadcasting (e.g. radio microphones). Some administrations are also investigating the use of the interleaved spectrum for “white space” devices. Reduction in spectrum available for DTTB use will lead to a disproportionate reduction in spectrum for those services, and may reduce it to the point where no viable business can be made for either the programme-making or the white space industries.

There are thus clear advantages in making decisions on any proposed digital dividend before the introduction of DTTB.

2.5 Conclusion

In conclusion, the introduction of DTTB relies mainly on political decisions. It is necessary to clarify and to assess the impact of different scenarios for the introduction of DTTB, and to clarify the role that DTTB is intended to serve in a particular market.

The possible sharing of spectrum with other services or release of spectrum for other services should, where possible, be decided before the introduction of DTTB.

Bibliography to Chapter 2

- [2.1] **ITU-D**, *Guidelines for the transition from analogue to digital broadcasting*, January 2014, <https://www.itu.int/en/ITU-D/Regional-Presence/AsiaPacific/Documents/AtoDguidelinesV3.pdf>
- [2.2] **ITU-R**, Report ITU-R BT.2140, *Transition from analogue to digital terrestrial broadcasting*.

CHAPTER 3

Requirements for the implementation of digital terrestrial television broadcasting networks

3.1 Introduction

In general, the requirements that need to be specified for the implementation of digital terrestrial broadcast networks can be grouped in three parts:

The User and Service requirements. They include the required:

- Picture quality (SD, HD, UHD, etc.)
- Audio quality (Number of Audio channels...)
- Type and number of Additional services (EPG, Access services...)
- Reception mode (fixed, portable, mobile)
- Number of programmes (Video + Audio and associated data)
- Target area/population coverage (percentage of the national area or population, possible obligation in terms of public service mission or national security)
- Service availability (Target Reception Location and Time Probabilities)

The Spectrum requirements. They include the required:

- Spectrum usage mode (MFN or SFN)
- Target frequency bands (Band III, IV, V) and extent of spectrum needed to implement the DTTB networks that meet all the requirements above.

The Receiver related requirements. They include the required:

- Minimum technical specifications to be able to receive the DTTB programmes (sensitivity, selectivity, operational frequency range, etc.).
- Connectivity characteristics and possible power supply to the active antenna through the feeder.
- Middleware for adopted hybrid broadcast broadband system.
- Conditional Access capabilities.

3.2 User and service requirements

3.2.1 Picture and audio quality

The Television Picture Resolution used for DTTB ranges from SD (Standard Definition) to Ultra-High definition (UHD). Early implementations of DTTB offered mainly SD pictures which are comparable to good PAL and SECAM analogue pictures. Then High Definition Television (HDTV) started to spread when large size flat displays became widely available and their prices decreased considerably. With time, even larger size 4k flat screens (exceeding 55”) became widely available and their price is continuously decreasing.

In terms of Audio, the quality ranges from stereo (2 channel) to surround (5.1 channel) Audio.

The required bit rate for a single Audiovisual programme with given Picture and Audio quality level will depend on the compression techniques used.

The figures provided in Tables 3.1 to 3.4 below are based on detailed information shown in EBU TR036 [3.1] and EBU TR015 [3.2]. They are related to the compression technique of the baseband audio-visual content and therefore are independent of the DTTB transmission system.

For each programme, a bit rate of 800 kbit/s is assumed for audio and associated data and included in the figures below. The figures for Video only (Video Bit Rate) and those including the bit rate required for Audio and associated data are shown in separate rows in each Table below.

It is also assumed that statistical multiplexing gain for 4 (or more) programmes is typically 20% on average⁶. This is applied to derive statmux bit rates from the bit rate without statmux in the Tables below.

NOTE – The values shown in Tables 3.1 to 3.4 below are typical but indicative. There may be differences between these values and what is or will be used in real networks. The actual data-rates used by individual broadcasters will depend on a trade-off between the economics of the available capacity in a multiplex, including the number of programmes to be made available, and the desired picture quality. There will also be differences due to the performance of video codecs at the time of implementation. Furthermore, the additional bit rate for audio and associated data may vary depending on the desired audio quality and the associated data.

TABLE 3.1

Estimated bit rate per programme for SD format

All values are in Mbits/s	SD, H.264 without statmux	SD, H.264 with statmux (4 or more programmes/pool)	SD, HEVC without statmux	SD, HEVC statmux (4 or more programmes/pool)
Video Bit Rate	1.875 ¹	1.5 ²	N/A ³	N/A
Video Bit Rate +0.8 Mbits/s audio and data	2.675	2.3	N/A	N/A

NOTE 1 – EBU TR036 [3.1], section 2.1:

SD MPEG2 Video statmux: 3 Mbits/s

SD MPEG2 Video without statmux (cancellation of the 20% decrease): $3/(1-0.2) = 3.75$ Mbits/s

SD H.264 Video without statmux (50% relative to MPEG2): 1.875 Mbits/s

SD H.264 Programme without statmux (+0.8) = 2.675 Mbits/s

NOTE 2 – 20% gain on the previous figure with statmux.

NOTE 3 – It is not foreseen to have HEVC based SDTV services. See clause 5.14 of ETSI TS 101 154 V2.2.1 (06/2015) [3.6] for “Specifications Common to all HEVC IRDs and Bitstreams”.

⁶ The 20% gain is the average gain between 15% (for 4 programmes) and 25% (for 10 programmes) indicated in Table 3.5.

TABLE 3.2

Estimated bit rate per programme for HD 720p/50 or 1080i/25 format

All values are in Mbits/s	HD 720p/50 or 1080i/25, H.264 without statmux	HD 720p/50 or 1080i/25, H.264 with statmux (4 or more programmes/pool)	HD 720p/50 or 1080i/25, HEVC without statmux	HD 720p/50 or 1080i/25, HEVC with statmux (4 or more programmes/pool)
Video Bit Rate	6 ¹	4.8 ²	2.8-3.5 ³	2.3-2.8
Video Bit Rate +0.8 Mbits/s audio and data	6.8	5.6	3.6-4.3	2.9-3.5

NOTE 1 – EBU TR036 [3.1] Table 1 first cell. To be noted that EBU TR015 [3.2] dated 2012 indicates 7 Mbits/s as being expected few years later. This means that the performance of H.264/AVC encoding equipment has improved more than expected since 2012.

NOTE 2 – 20% gain on the previous figure with statmux.

NOTE 3 – In EBU TR036 [3.1], Table 1 second cell (approach 1) indicates 3.5 Mbits/s video bit rate for HD 720p/50 while the explanation under Table 3 (approach 2) indicates 2.8 Mbits/s video bit rate for HD 1080i/25 (which requires similar bitrate as 720p/50). This large range is explained by the different generations of encoders considered in each of the approaches. For comparison, Rec. ITU-R BT.2073-0 [3.3] indicates in its Table 1.1a maximum required constant bit rate for critical sequences of 10-15 Mbits/s.

TABLE 3.3

Estimated bit rate per programme for HD 1080p/50 format

All values are in Mbits/s	HD 1080p/50, H.264 without statmux	HD 1080p/50, H.264 with statmux (4 or more programmes/pool)	HD 1080p/50, HEVC without statmux	HD 1080p/50, HEVC with statmux (4 or more programmes/pool)
Video Bit Rate	6-8 ¹	4.8-6.4 ²	3.5-3.6 ³	2.8-3.0 ³
Video Bit Rate +0.8 Mbits/s audio and data	6.8-8.8	5.6-7.2	4.3-4.4 ⁴	3.6-3.8 ⁵

NOTE 1 – EBU TR015 [3.2] dated 2012 indicates 10 Mbits/s as being expected few years later. However, as shown in Table 3.2 above for the case of HD 720p/50, the performance of H.264/AVC encoding equipment has improved more than expected since 2012, therefore a range 6 to 8 Mbits/s is indicated.

NOTE 2 – 20% gain on the previous figure with statmux.

NOTE 3 – Figures from lower cell – 0.8 Mbits/s.

NOTE 4 – EBU TR036 [3.1] Table 5 second cell. For comparison, Rec. ITU-R BT.2073-0 [3.3] indicates in its Table 1.1a maximum required constant bit rate for critical sequences of 10-15 Mbits/s.

NOTE 5 – EBU TR036 [3.1] Table 5 second cell.

TABLE 3.4

Upper and lower bound of estimated total data rates per programme for UHD 2160p/50 format

All values are in Mbits/s ¹	UHD 2160p/50, HEVC without statmux	UHD 2160p/50, HEVC with statmux
Lower bound	10.4-14.8	9.25-12.0
Upper bound	22.5 ²	20.7 ³

NOTE 1 – All values are taken from EBU TR036 [3.1] Table 8.

NOTE 2 – For comparison, Rec. ITU-R BT.2073-0 [3.3] indicates in its Table 1.1a maximum required constant bit rate for critical sequences of 30-40 Mbits/s.

NOTE 3 – With a statmux gain of 8% for two programmes in the multiplex.

3.2.2 Associated audio and data

Audio: 0.2 to 0.5 Mbits/s (0.25 Mbits/s used in the tables above) – dependent on number of audio channels (stereo/surround sound/multilingual);

Service Information and EPG: (SI) 0.1 to 0.3 Mbits/s (0.15 Mbits/s used in the Tables above);

Interactivity/Teletext: 0.1 to 1.0 Mbits/s (0.2 Mbit/s used in the Tables above);

Access services (subtitles/audio description/spoken subtitles): 0.2 Mbits/s.

Integrated broadcast-broadband services:

Recommendation ITU-R BT.2075 [3.7] considers three Integrated broadcast-broadband (IBB) systems: HbbTV, Hybridcast and HTML5 based/Smart TV Platform.

Concerning the required bit rate for IBB services in a DTT multiplex, it depends on the allocation made by the broadcaster of IBB content to be transmitted by DTT and that to be transmitted by the broadband (Internet) connection.

In situations where internet connections are fast and reliable, it is likely that majority of IBB content is provided via the Internet. In this case the only thing needed is to get the IBB offerings connected to the right services (for example in HbbTV this correspond to having the right “red button” popping up at each TV programme). The required data rate on the DTT multiplex depends on the number of IBB apps in the offering. Taking HbbTV as example, 2 kbits/s would be required for only one application. As there are several TV services in a DTT multiplex and several applications are proposed in each service, it is likely that several tens of kbits/s would be required in a single DTT multiplex.

In situations where Internet connections are slow and where spare multiplex capacity is available, it is possible to transmit the IBB applications via the DTT broadcast channel itself. In the HbbTV example, this is done by using the DSM-CC data carousel; see HbbTV 2.0 Specification [3.8]. In this case, up to several Mbit/s may be needed for an attractive offering, including pictures for example, and loading in an acceptable time. Typical data rates for such usage would be in the range 500 kbits/s to 2 Mbits/s.

For further details on Integrated Broadcast Broadband systems, see Chapter 10.

3.2.3 Standalone sound radio programmes (Sound radio over DTTB)

DTTB systems can be used for transmission of standalone sound radio programmes as part of a multiplex of services. In addition to the data allocated to the audio component of such programmes, some data-rate may be required for (for example) a caption to be displayed on-screen while tuned to the audio service. This can be accomplished with as little as 5-10 kbit/s.

The data-rate needed for the audio component depends on the coding system used, as well as the audio format chosen. For example, a mono programme in AC3 coding might be carried with 64 kbit/s or less, while a multi-channel programme might require 300 kbits/s or more.

Older DTTB systems used MPEG Layer 2 coding, and required consequently higher data-rates for audio services: typically, 160 kbits/s might have been used for a stereo programme.

3.2.4 Reception mode

Four reception modes are possible with DTTB:

- Fixed rooftop antenna reception
- Portable indoor/outdoor reception⁷
- Hand held reception
- Mobile reception

The requirement for one or other of these reception modes depends on the actual situation in the country. In countries where fixed roof top reception is still widely used, DTTB implementation is usually made for this reception mode. In those countries with large satellite and cable penetration rates, it is often the portable and mobile reception modes which are usually selected.

Chapter 4 provides technical parameters for DTTB which are suitable for each of these reception modes.

3.2.5 Number of audio-visual programmes

The number of audio-visual programmes that can be accommodated in one 6, 7 or 8 MHz channel depends on the bit rate required for a single programme (shown in section 3.2.1) and the capacity of the channel which depends on the modulation system used and whether statistical multiplexing is used or not.

In Annex 2 to Chapter 4, several DTTB scenarios based on the different DTTB systems are described. Using those scenarios, the number of SD, HD and UHD programmes that may be accommodated in a multiplex can be calculated.

For the sake of clarity, the statistical multiplex gain figures reported in [3.1] are used; these are reproduced in Table 3.5. A particular value is given for each number of programmes per multiplex. These are more detailed than the representative values used in § 3.2.1. It should be kept in mind that these figures are average values obtained from experience and that they may differ slightly in individual cases.

TABLE 3.5
Statistical multiplexing gain as a function of the number of programmes per multiplex
(reproduced from [3.1])

Number of programmes per multiplex	Statistical multiplexing gain (%)
1	0
2	8
3	12
4	15
5	17.5
6	19

⁷ Note on “stationary indoor reception”: In countries that follow the planning principle “portable outdoor” (in the ITU GE06 Frequency Plan this is called RPC2) the TV signal can be received indoor within a relatively large area around the TV transmitter. Thus, stationary set-top boxes and TV sets may operate with small indoor antennas connected to the DTTB receive device. Germany is such an example where virtually all households in agglomerations use (or can use) such an indoor antenna for the reception of DTTB, connected permanently to their stationary set-top boxes or their (typically large screen) TV sets.

TABLE 3.5 (end)

Number of programmes per multiplex	Statistical multiplexing gain (%)
7	21
8	23
9	24
10	25

Table 3.6 shows the results for few examples of scenarios described in terms of data rate offered by the DTTB system in one 6, 7 or 8 MHz channel. Specific figures of data rates for different DTTB systems can be found in Annex 2 to Chapter 4.

Note that in this Table the numbers of programmes are given to the first decimal, although in practice only an integer number of programmes can be accommodated. Also statistical multiplexing gain is included based on Table 3.5.

Note that results for 720p/50 are assumed to be identical to those for 1080p/50.

TABLE 3.6

Number of programmes in one 6, 7 or 8 MHz channel depending on the data rate offered by examples of DTTB implementation scenarios

Scenario	1	2	3	4
	(Example DVB-T2, fixed rooftop reception using an 8 MHz channel and MFN planning – See A4.2.1.1 of Annex 2 to Chapter 4)	(Example ISDB-T, fixed rooftop reception using a part (layer) of a 6 MHz channel – See A4.2.2 of Annex 2 to Chapter 4)	(Example DTMB, fixed rooftop reception using an 8 MHz channel and MFN planning – See A4.2.3.1 of Annex 2 to chapter 4)	(Example ATSC, fixed rooftop reception using a 6 MHz channel – See A4.2.4 of Annex 2 to Chapter 4)
Data rate	40.2 Mbit/s	16.85 Mbit/s	32.486 Mbit/s	19.39 Mbit/s
SDTV H.264 statmux	18.2	7.4	14.7	8.6
HDTV 720p/50 or 1080i/25 H.264 statmux	7.3	2.7	5.6	3.2
HDTV 1080p/50 H.264 statmux	5.4-7.3	2.1-2.7	4.3-5.6	2.4-3.2
HDTV 720p/50 or 1080i/25 HEVC statmux	11.7-13.9	4.5-5.4	9.4-11.2	5.3-6.3
HDTV 1080p/50 HEVC statmux	11.5-11.7	4.4-4.5	9.2-9.4	5.1-5.3
UHDTV 2160p/50 HEVC statmux maximum	2.9-4.2	1.1-1.5	2.3-3.3	1.2-1.7

TABLE 3.6 (end)

Scenario	1	2	3	4
UHDTV 2160p/50 HEVC statmux minimum	1.7	0.7	1.4	0.8

NOTE – The Table above aims only at showing how to derive the number of programmes that can be offered by examples of data-rates. The transmission data-rates selected refer to different bandwidths and more importantly, to different levels of robustness (such as different error protection schemes). Therefore, the table should not be used to compare the performance of DTTB systems in terms of offered data-rates. For more details see Annex 2 to Chapter 4.

3.2.6 Target coverage

As mentioned in Chapter 2, the target coverage is a regulatory and economic issue for the country which is implementing DTTB networks. In some countries, the public service obligations impose universal (approaching 100%) coverage over the territory or the population. In other countries or for commercial broadcasting, lower targets may be defined. The defined target coverage corresponds to the service area for the intended broadcast service. The protection of this service area is dealt with in Chapter 4.

3.2.7 Reception availability

The required reception availability in locations and in time has an impact on the planning signal levels. The higher the target availability, the more demanding the network is in terms of transmission power and spectrum requirements (in order to reduce the short term interference levels between distant broadcasting transmitters). Typical values for reception availability are 95% for fixed roof top, portable indoor/outdoor and hand-held reception and 99% for mobile reception. Broadcasters or regulators may choose other values for their own reasons.

For further details, refer to section 4.5.7 in Chapter 4.

3.3 Spectrum requirements

The spectrum requirements for a DTTB network are expressed in terms of range of spectrum needed to implement the network, even if not all the spectrum is used in every point of the territory. This is due to the need for a buffer area around a given transmitter where the same frequency of that transmitter cannot be reused in MFN (Multi-Frequency Network) spectrum usage mode. Even though the SFN (Single Frequency Network) mode is attractive for the improved spectrum efficiency that it offers, there are many cases where the MFN mode is the best or the only practical choice. This is for example the case where the content cannot be identical over large areas (either due to local content change or simply between two sides of a border). It is also the case where the cost of implementing SFNs is considered too high in terms of effective implementation (additional special equipment and very careful planning are needed), or in terms of reduction of capacity due to the need for a larger guard interval to implement large SFNs.

In an increasing number of countries, the choice of a mixed MFN and SFN implementation is made. This consists in implementing an MFN of SFN “islands”. This allows a useful trade-off between the constraint of reduced capacity due to the use of large guard interval and the constraint of reduced spectrum efficiency due to the use of usual MFN implementation.

Chapter 4 provides a comprehensive explanation of MFN and SFN modes.

The required range of spectrum can include the VHF range (47-68 MHz and 174-216 MHz in the USA for example, 174-230 MHz in Region 1) and all or part of the UHF range (470-862 MHz). The main differences between these two ranges are the propagation characteristics (more far-reaching in VHF than in UHF) and the required antenna sizes (larger in VHF than in UHF).

While this Handbook focuses on frequency bands below 1 GHz, for which DTTB systems have been designed and DTTB networks planned, it should be noted that there are other bands also allocated to broadcasting, for example the L-Band, 1 452-1 492 MHz, planned in Europe for T-DAB (Terrestrial Digital Audio Broadcasting).

The spectrum range(s) required for DTTB implementation need to be harmonized as this creates the required conditions for mass market production of transmission and receiving equipment, reducing consequently their prices while allowing for improved performances.

The ITU-R has carried out two surveys on spectrum requirements for broadcasting:

- 1) Between May 2012 and March 2014 for Region 1 and the Islamic Republic of Iran. Report ITU-R BT.2302 [3.4] provides the results of this survey. Based on this Report, it is concluded that at least the 28 channels of 8 MHz bandwidth (224 MHz) in the range 470-694/698 MHz are required to satisfy the spectrum requirements for the broadcasting service for the majority of administrations who responded. This has been confirmed by the re-planning exercise done in the African Broadcasting Area prior to WRC-15 (see Chapter 6).
- 2) Between December 2014 and July 2015 for all ITU Member States and Sector Members. Report ITU-R BT.2387 [3.5] provides the results of this survey. From the responses to the survey, the following points are noted:
 - a) there is a migration towards UHF from VHF Bands I, II and III for the implementation of DTTB and a significant number of countries will reduce the spectrum occupied by DTTB in the UHF Bands. As a consequence the band primarily used by DTTB after ASO (Analogue Switch-Off) and channel restacking will be within 470-694/698 MHz;
 - b) nearly all countries operating or planning the introduction of DTTB have indicated a desire for new and enhanced broadcast services. The most frequently referenced new service is HDTV with most countries operating or planning its implementation. UHDTV is also popular with a number of countries trialing systems and studying the requirements. Interest has also been expressed in 3DTV and a number of audio and video enhancements;
 - c) the majority of countries share their television broadcast bands with other primary or secondary services, although the number of countries where the other primary service is allocated spectrum within DTTBs minimum and maximum operational frequency is significantly less, especially after restacking is taken into consideration;
 - d) despite the number of countries that have just implemented or have still to implement ASO, it is interesting to note that several are already considering the future options for the further development of DTTB e.g. HDTV, UHDTV;
 - e) provision of local DTTB is extensive in some countries.

3.4 Receiver related requirements

The operational and technical characteristics of the DTTB receiver (including Set-top boxes, TV sets and receiving antennas) are essential for adequate reception of the services.

The technical specifications should be based on the selected DTTB implementation scenario, in terms of sensitivity of the DTTB receiver.

The selectivity and the operational frequency range of the DTTB receiver should be based on the national spectrum allocations to DTTB and to other services in adjacent bands.

The use of active antennas, in countries where portable and mobile reception is planned, requires supplying the external antenna with power through the antenna cable directly from the receiver.

The availability of hybrid broadcast broadband services on the DTTB platform would require specifying a suitable capability and connectivity of the DTTB receiver to the broadband platform in addition to its capability and connectivity to the broadcast platform.

Also the capability of the receiver to run the software associated with the hybrid broadcast broadband system needs to be specified in the receiver requirements.

Chapter 13 “Digital TV receivers” provides a detailed overview of the DTTB receiver requirements.

The use of conditional access to provide pay TV on the DTT platform requires additional technical and operational characteristics of the DTTB receiver. Conditional access aspects are dealt with further in detail in Chapter 11 “Conditional access and content protection in digital television broadcasting”.

References

- [3.1] **EBU** Tr036, TV programme accommodation in a DVB-T2 multiplex for (U)HDTV with HEVC video coding, Technical report, version 1.0, Geneva March 2016.
- [3.2] **EBU** Tr015, Defining Spectrum Requirements of Broadcasting in the UHF Band, July 2012.
- [3.3] Recommendation **ITU-R** BT.2073-0 – Use of the high efficiency video coding (HEVC) standard for UHD TV and HDTV broadcasting, February 2015.
- [3.4] Report **ITU-R** BT.2302-0 – Spectrum requirements for terrestrial television broadcasting in the UHF frequency band in Region 1 and the Islamic Republic of Iran, April 2014.
- [3.5] Report **ITU-R** BT.2387-0 – Spectrum/frequency requirements for bands allocated to broadcasting on a primary basis, July 2015.
- [3.6] **ETSI** Specification for the use of Video and Audio Coding in Broadcasting Applications based on the MPEG-2 Transport Stream, TS 101 154, V2.2.1, 06/2015.
- [3.7] Recommendation **ITU-R** BT.2075 – Integrated broadcast-broadband system.
- [3.8] **HbbTV Association** HbbTV 2.0 Specification, 01/05/2015.

CHAPTER 4

Broadcast network planning

4.1 Digital terrestrial television networks

Coded DTTB signals need to be distributed between studios and coding/multiplexing centres, and onwards to transmitter sites (“primary distribution” networks). Often these are distributed as MPEG-2 or MPEG-4 transport streams, although in future, these may evolve to ITU-T H.265 (HEVC) transport streams or IP connections. Such distribution circuits may be provided by the broadcaster, or by a telecoms operator offering long-distance connectivity. The decision on which of those to use will depend on economic and/or regulatory considerations.

Possible choices for the technology to be used in the distribution networks are optical fibre, coaxial cable, satellite, microwave and twisted pairs through PDH or SDH ATM, DVB or IP technologies; of course, a real network may use a combination of these techniques. The timing of the distribution must be controlled to ensure that it does not induce jitter in decoders, and to ensure stable synchronization of multiplexers and modulators. Standards for transporting MPEG-2 or MPEG-4 signals in primary distribution networks have been prepared by DVB. Further guidance is given in ETSI TR 101 200 [4.1].

Further considerations on the quality required of these primary distribution networks are given in Chapter 7.

The “secondary distribution” network carries the digital signal from the primary distribution networks to the TV sets. Such networks consist of combination of transmitters and repeaters (gap-fillers) operating at powers varying from many ten of kilowatts to only a few watts. In general, a national coverage based on the use of a terrestrial broadcasting infrastructure can achieve coverage of a high percentage of the population. The principles of such networks, and the planning considerations needed for them, form the remainder of this chapter.

4.2 Basic terms and definitions

4.2.1 Digital terrestrial television broadcasting (DTTB)

A variety of different digital terrestrial television systems have been standardised in the following ITU-R Recommendations:

- BT.1306 – Error correction, data framing, modulation and emission methods for digital terrestrial television broadcasting [4.2] contains details of four systems: ATSC, DVB-T, ISDB-T and DTMB.
- BT.1877 – Error-correction, data framing, modulation and emission methods for second generation of digital terrestrial television broadcasting systems [4.3] contains details of DVB-T2.
- BT.2016 – Error-correction, data framing, modulation and emission methods for terrestrial multimedia broadcasting for mobile reception using handheld receivers in VHF/UHF bands [4.4] contains details of 6 systems: T-DMB, AT-DMB, ISDB-T for mobile reception, DVB-SH, DVB-H, DVB-T2 Lite.

These systems are discussed in more detail in Chapter 9.

4.2.2 Frequency bands

In this Handbook, we consider the following three frequency bands that are allocated to the broadcasting service and used for broadcast television:

- **Band III:** Frequency range 174-230 MHz in Region 1, 174-216 MHz in Region 2, and 174-223 MHz in Region 3. In Region 3, there are co-primary allocations to the fixed and the mobile service. In Region 1, this band is also used for digital audio broadcasting.

- **Band IV:** Frequency range 470-582 MHz. WRC-15 [4.5] also allocated all or parts of this frequency range to the mobile service in a small number of countries in Regions 2 and 3.
- **Band V:** Frequency range 582-862 MHz (Region 1), 582-890 (Regions 2 and 3). For Region 1, WRC 2007 [4.6], 2012 [4.7] and 2015 [4.5] also allocated, in three steps, the upper part of Band V (694-862 MHz) to the mobile service on a primary basis. Region 2 has additional allocations to the mobile service from 698-890 MHz and, in Region 3, various possibilities for the mobile service exist within the whole UHF TV range up to 890 MHz. Refer to the Final Acts of WRC-15 [4.5] for other services allocated in Region 1.

For details of mobile and fixed allocations in all these bands, see Article 5 of the ITU Radio Regulations, Edition of 2015 [4.8].

Band III is part of the VHF, Very High Frequency, range and Bands IV and V are part of the UHF, Ultra-High Frequency, range.

4.2.3 Coverage area

The coverage area of a broadcasting station, or a group of broadcasting stations, is the area within which the wanted field strength is equal to or exceeds the usable field strength defined for specified reception conditions and for an envisaged percentage of covered receiving locations.

In defining the coverage area for each reception condition, a three-level approach is taken:

- **Level 1: Receiving location** – The smallest unit is a receiving location; optimal receiving conditions will be found by moving the antenna up to 0.5 m in any direction. A receiving location is regarded as being covered if the level of the wanted signal is high enough to overcome noise and interference for a given percentage of the time.
- **Level 2: Small area coverage** – The second level is a “small area” (typically 100 m by 100 m). In this small area the percentage of covered receiving locations is indicated.
- **Level 3: Coverage area** – The coverage area of a broadcasting station, or a group of broadcasting stations, is made up of the sum of the individual small areas in which a given percentage (typically between 70% and 99%) of coverage is achieved.

In section 4.5, methods to calculate the coverage area and information on its evaluation are described in detail.

4.2.4 Service area

The part of the coverage area within which the administration has the right to require that the agreed protection conditions be provided.

4.2.5 Reception modes

A terrestrial broadcasting network can be planned for different main reception modes: fixed rooftop antenna reception, portable reception for a static reception or for handheld portable pedestrian reception and mobile reception in a car.

4.2.5.1 Fixed rooftop antenna reception

Fixed reception is defined as reception where a directional receiving antenna mounted at roof level is used.

It is assumed that near-optimal reception conditions (within a relatively small volume on the roof) are found when the antenna is installed.

In calculating the field strength for fixed antenna reception, a receiving antenna height of 10 m above ground level is considered to be representative for the broadcasting service.

The receiving antenna gain and antenna discrimination are taken into account for network planning. Recommendation ITU-R BT.417 [4.9] provides the parameters to be used in such calculations.

NOTE – When installing narrow-band (and usually high-gain) receiving antennas, they should not be used for the reception of DTTB signals using frequencies outside of the band for which the antenna is specified.

4.2.5.2 Portable reception

Portable reception is defined as the reception at rest (stationary reception) or at very low speed (walking speed) where a portable receiver with an external (for example a telescopic antenna or a wired headset) or integrated antenna is used at no less than 1.5 m above ground level. Portable reception takes place under a great variety of conditions (outdoor, indoor, ground floor and upper floors):

- class A (outdoor), which means reception where a portable receiver with an attached or built-in antenna is used outdoors at no less than 1.5 m above ground level;
- class B (ground floor, indoor), which means reception where a portable receiver with an attached or built-in antenna is used indoors at no less than 1.5 m above floor level in rooms with the following characteristics:
 - a) on the ground floor; and
 - b) with a window in an external wall.

Portable indoor reception on the higher floors will be regarded as class B reception with signal level corrections applied.

In both classes A and B, it is assumed that:

- optimal receiving conditions will be found by moving the antenna (or receiver if it has a built-in antenna) up to 0.5 m in any direction;
- the portable receiver is not moved during reception and large objects near the receiver are also not moved;
- extreme cases, such as reception in shielded rooms, are disregarded.

4.2.5.3 Handheld reception

Handheld portable reception is defined as the reception at rest (stationary reception) or at very low speed (walking speed) where a receiver with an external (for example a telescopic antenna or a wired headset) or integrated antenna is used at no less than 1.5 m above ground level. Hand-held receivers may also suffer from body-absorption/reflection loss in certain circumstances, e.g. when the receiver is in a pocket. Handheld portable reception takes place under a great variety of conditions (outdoor, indoor, ground floor and upper floors). In addition, the handheld receiver will probably be moved (at walking speed) while being viewed. As a result, different planning parameters are used for handheld reception compared with the similar case of portable reception.

For the hand-held reception mode, it is often possible to improve reception by moving the receiver and/or antenna position and/or by having an antenna with higher efficiency. It is to be expected that there will be significant variation of reception conditions for indoor portable reception, which may also depend on the floor-level at which reception is required. There will also be considerable variation of building penetration loss from one building to another and considerable variation from one part of a room to another. It is to be expected that "portable coverage" will often only be achieved in urban and suburban areas.

4.2.5.4 Mobile reception

Mobile reception is defined as the reception of a signal by a receiver in motion with an antenna situated at no less than 1.5 m above ground level. This could for example be a car receiver or handheld equipment.

The term motion covers speeds from a walking person to a car driven on a motorway. High-speed trains, buses and other vehicles could be also considered.

The dominant factor with regard to local reception effects is fading in a Rayleigh channel. Fade margins are intended to offset these effects. Fade margins depend on the frequency and the velocity.

The principal constraint for mobile reception is the fact that the receiving antenna cannot be adjusted while moving. Consequentially the field strength requirement is accordingly higher than for portable and stationary reception (see also section A4.1.2).

4.2.6 Assignment planning

In assignment planning, a specific channel is assigned to an individual transmitter location with defined transmission characteristics (for example, radiated power, antenna height, etc.). More details are given in section 4.4.2.1.

4.2.7 Allotment planning

In allotment planning, a specific channel is “given” to an administration to provide coverage within its territory over a defined area, called the allotment area. Transmitter sites and their characteristics are unknown at the planning stage and are defined at the time of the conversion of the allotment into one or more assignments. More details are given in section 4.4.2.2.

4.2.8 Test points

A test point is a defined geographical location at which specified calculations are carried out.

4.2.9 Nuisance field strength

The nuisance field strength (E_n), expressed in dB ($\mu\text{V/m}$), is the field strength, for 50% of locations and for a given percentage of the time, of an unwanted signal from any potential interfering source, to which has been added the relevant protection ratio in decibels.

NOTE 1 – Where relevant, the appropriate value in decibels of receiving antenna directivity or polarization discrimination must be taken into account.

NOTE 2 – Where there are several unwanted signals, a method for combination of individual nuisance field strengths shall be applied, such as the power sum method or some other appropriate method for signal summation, in order to obtain the resultant total nuisance field strength.

4.2.10 Minimum usable field strength/minimum field strength to be protected

Minimum value of the field strength necessary to permit a desired reception quality, under specified receiving conditions, in the presence of natural and man-made noise, but in the absence of interference from other transmitters.

NOTE 1 – The term “minimum usable field strength” corresponds to the term “minimum field strength to be protected” which appears in many ITU texts and it also corresponds to the term “minimum median field strength”, which appears in this chapter as E_{med} used for coverage by a single transmitter only.

4.2.11 Usable field strength

Minimum value of the wanted field strength necessary to permit a desired reception quality, under specified receiving conditions, in the presence of natural and man-made noise and of interference, either in an existing situation or as determined by agreements or frequency plans.

NOTE 1 – The term “usable field strength” corresponds to the term “necessary field strength” which appears in many ITU texts.

NOTE 2 – The usable field strength is calculated by combining the individual nuisance field strengths (E_n) and the combined location correction factor. One of the individual nuisance field-strength contributions is the minimum median field strength (E_{med}), which represents the noise level.

4.2.12 Reference field strength

The agreed value of the field strength that can serve as a reference or basis for frequency planning.

NOTE 1 – Depending on the receiving conditions and the quality required, there may be several reference field-strength values for the same service (for different reception scenarios).

4.2.13 Minimum median field strength E_{med} (dB(μ V/m))

The appropriate value of minimum usable field strength to be used for coverage by a single transmitter only, being a value for 50% of locations and for 50% of the time at 10 m above ground level.

NOTE 1 – E_{med} depends on the median value of the minimum field strength (E_{min}) at the receiving place which is required for a given percentage of locations and percentage of the time to ensure that the minimum signal level necessary for the receiver to successfully decode the signal is achieved.

NOTE 2 – E_{med} is calculated from the minimum field strength (E_{min}) by adding, where relevant, appropriate correction factors such as height loss, building entry loss etc. which are described in Appendix 3.4 to Chapter 3 of Annex 2 of the GE06 Agreement [4.10].

NOTE 3 – In the case of wideband signals where the spectral power density may not be constant across the occupied bandwidth, the term “field strength” is often replaced by the term “equivalent field strength”. The equivalent field strength is the field strength of a single unmodulated RF carrier radiated with the same power as the total radiated power of the wideband signal.

4.2.14 Coordination trigger field strength

Field-strength level which, when exceeded, determines that coordination is required (also referred to as trigger field strength).

4.2.15 Network configurations: MFN, SFN or mixed MFN-SFN

There is also a choice of architectures for the transmission infrastructure: MFNs, SFNs or mixed MFN-SFN (see below).

The type of network implemented will depend on the availability of frequencies, the type of coverage required, and the number of multiplexes to be provided.

4.2.15.1 Multi Frequency Network (MFN)

In the GE06 Agreement [4.10], an MFN is defined as a network of transmitting stations using several RF channels.

In an MFN each transmitter uses a different channel, acting independently and having its own coverage area. Reuse of channels is possible, given sufficient geographical separation between the coverage areas.

4.2.15.2 Single-frequency network (SFN)

An SFN is defined in the GE06 Agreement [4.10] as a network of synchronized transmitting stations radiating identical signals in the same RF channel.

The use of SFNs is facilitated by the multi-carrier orthogonal frequency division multiplexing (OFDM) modulation technique which enables the reception and, under certain circumstances, constructive summation of more than one useful RF signal.

4.2.15.3 Mixed MFN-SFN

A mixed MFN-SFN environment can also be envisaged. This may be encountered in the following cases:

- within an MFN using high power main stations, if one such station does not provide complete coverage, lower power relay stations (gap-fillers or repeaters) may complete the coverage using the same frequency as the associated main station. This configuration is sometimes called a hybrid MFN-SFN;
- another case may consist, for example, of using an MFN structure for transmitting a national multiplex and a series of SFN structures for transmitting a regional multiplex;
- in other cases, this type of mixed network scenario could arise from different approaches in adjacent countries (e.g. an MFN approach in one country and an SFN approach in the other).

4.2.16 Reference planning configuration (RPC)

A representative combination of planning criteria and parameters to be used for frequency planning purposes.

4.2.17 Reference network (RN)

A generic network structure representing a real network, yet unknown, for the purposes of a compatibility analysis. The main purpose is to determine the potential for and susceptibility to interference of typical digital broadcasting networks.

4.2.18 Digital Plan entry

An assignment, or an allotment, or a combination of assignments that may or may not be linked to a single allotment and that, for the purposes of the implementation of a plan such as GE06 [4.10], is treated as a single entity.

4.3 DTTB network considerations: physical layer and parameters

It must be recognized that digital broadcasting frequency planning is a multidimensional subject requiring many technical inputs:

- criteria such as minimum signal levels, protection ratios and
- parameters such as inter-transmitter distance, transmitting antenna heights and type of receptions.

There is no single and universal solution. In a first approach of initial planning, it may be necessary to restrict the planning studies to a representative subset of criteria and parameters.

Furthermore, when designing a digital terrestrial network, account must be taken of the fact that digital television service coverage is characterized by a very rapid transition from near perfect reception to no reception at all and it thus becomes much more critical to be able to define which areas are going to be covered and which are not.

The network configurations and reception modes can evolve from one configuration to another due to the flexibility of the digital systems. Networks can provide flexibility in order to cope with future demands (for example, a conversion from fixed antenna reception to portable and mobile reception may require an evolution from a high-power, high-tower MFN to a more homogeneous SFN configuration). Various possible deployment scenarios are given in Annex 2 to Chapter 4.

DTTB standards specify a hierarchical mode and a non-hierarchical mode. The hierarchical modes when applicable split the channel in two with different (and adjustable) requirements in terms of C/N . This allows different reception conditions for the same or for different programme contents.

4.3.1 DTTB variants

The DTTB standards permit flexibility which allows broadcasting planners to tailor their networks by implementing the most appropriate variant among the different possible modes of operation.

DTTB should fit into existing 6, 7, 8 MHz TV channels and the choice of broadcasting system will depend on specific conditions such as spectrum availability, coverage requirements, structure of existing network, reception conditions.

Various DTTB systems that may be used in different frequency bands and a schematic description can be found in Report ITU-R BT.2295 [4.11].

The current systems available for the implementation of a DTTB network are shortly described below.

ATSC⁸. ATSC standards are a set of standards developed by the Advanced Television Systems Committee for digital television transmission over terrestrial, cable, and satellite networks. ATSC Mobile DTV is an enhancement of the ATSC system to provide multimedia services including video, audio, and interactive data service delivery to small (power efficient) receivers, for fixed, handheld and vehicular environments.

DTMB. DTMB (Digital Terrestrial Multimedia Broadcast) is a TV standard for mobile and fixed terminals. DTMB system is compatible with fixed reception (indoor and outdoor) and mobile digital terrestrial television. Mobile reception is compatible with standard definition digital TV broadcasting, digital audio broadcasting, multimedia broadcasting and data broadcasting service. Fixed reception in addition to the previous services also supports high definition digital TV broadcasting.

DVB-T. DVB-T is the standard for the broadcast transmission of digital terrestrial television. The system transmits compressed digital audio, digital video and other data in an MPEG-2 transport stream, using COFDM modulation.

DVB-H and **DVB-SH**. These systems are end-to-end broadcast systems for delivery of any types of digital content and services using IP-based mechanisms optimized for devices with limitations on computational resources and battery. They consist of a unidirectional broadcast path that may be combined with a bidirectional mobile cellular (2G/3G) interactivity path. The broadcast path of DVB-SH system uses combined or integrated satellite and terrestrial networks.

DVB-T2. DVB-T2 is a 2nd generation terrestrial broadcast transmission system. The main purpose was to increase capacity, ruggedness and flexibility to the DVB-T system. DVB-T2 Lite is the DVB-T2 profile designed to efficiently deliver TV and radio for and mobile devices such as phones and tablets.

ISDB-T. The ISDB-T family (ISDB-T, ISDB-TSB, ISDB-T multimedia systems) was designed based on the OFDM band-segmented transmission scheme. One OFDM segment corresponds to 1/13 of the bandwidth of a television channel. The number of segments can be chosen in accordance with the available bandwidth and application.

4.4 Broadcast network planning

4.4.1 Basic principles of frequency planning

In a general sense, planning and coordination of DTTB system in MFN or SFN mode follows the same lines and rules as are well known from the procedures of coordination for analogue broadcasting services. However, some of the new features of DTTB system have also an impact on the way the new digital services are to be coordinated.

The allotment approach is often felt as the more appropriate way to describe SFN service areas in coordination procedures, since for an SFN the coverage area is a unique and undividable object, which corresponds in the allotment approach with the envisaged service area.

4.4.2 Planning approaches

4.4.2.1 Assignment planning

In the past, terrestrial television planning (and most other broadcasting) in Europe has been implemented by way of assignment conferences. In assignment planning, a significant amount of individual station planning is needed to prepare for a planning conference.

⁸ Note on ATSC 3.0 – Currently, the Advanced Television Systems Committee is working on a next-generation ATSC system specification, entitled ATSC 3.0. This system will use COFDM for improved mobile reception; the multiplex will be IP based (like streaming services) rather than using the MPEG Transport Stream. At the time of writing of this handbook, the specification was not yet finalised and approved. Consequently, ATSC 3.0 is not yet included in an ITU Recommendation.

In assignment planning, a specific channel is assigned to an individual transmitter site location with defined transmission characteristics (for example, radiated power, antenna height, etc.). At the completion of the assignment plan, the locations and characteristics of all transmitters are known and the transmitters can be brought into service without further coordination.

Assignment planning, based on a lattice structure, for terrestrial digital television is appropriate where all the transmitter sites can be assumed to have the same characteristics. This is not to say that station characteristics are fixed for all times. For example, the ST-61 Agreement [4.12] allows for some flexibility and indeed there have subsequently been many modifications and additions to the Plan.

The assignment plan provides a frequency for each station and at the completion of the assignment planning process, the locations and characteristics of the transmitters in the planning area are known. The transmitters can be brought into service without further coordination.

For practical reasons a lower limit for the radiated power is normally defined for stations to be dealt with in the regional planning process (e.g. at the RRC in Geneva 2006). Stations with a radiated power below the limit are then included in the plan subsequently. For example in GE06 the lower limit was set to 50 W for VHF stations and to 250 W for UHF stations.

4.4.2.2 Allotment planning

The possibility of obtaining allotments at a terrestrial broadcasting conference has received attention in recent years, particularly because of the opportunities offered by SFN. Allotments may also be applicable for MFN planning where a country has no plans to use specific transmitter sites and wishes to retain some flexibility for the future.

In allotment planning, a specific channel is “given” to an administration to provide coverage over a defined area, called the allotment area. The parameters required for planning are the allotment area, the channel and the interference potential of the allotment. Transmitter sites and their characteristics are unknown during planning and should be defined at the time of the conversion of the allotment into one or more assignments.

Thus in order to carry out planning it is necessary to define some reasonably realistic reference transmission conditions, which represent the potential interference which could be caused, so that any necessary compatibility calculations can be made. These are called reference networks and Annex A1.3 provides more detailed consideration of them.

The resulting allotment plan shows the frequencies to be used in particular areas without specifying the stations to which the frequencies are assigned.

4.4.2.3 The link between allotment and assignment planning

An assignment plan contains the detailed transmitter data from the day it is established and therefore allows for implementation immediately when the plan comes into force. However, subsequent changes to the network are likely to require coordination with relevant neighbours.

The coverage area of an assignment can be mapped to an allotment by approximating its coverage area as appropriate. However, the assignment planning approach implicitly defines some form of coverage.

In order to implement an allotment, it is necessary to convert the allotment into individual transmitter assignments. The detailed technical characteristics of the transmitters are normally planned subsequent to a planning conference, but can also be established during a conference, if required. Each allotment may then contain several transmitters forming an SFN or, in the simplest case, a single transmitter. Due to the definition of an allotment the transmitters, or transmitter, may subsequently be modified without coordination providing that the outgoing interference does not exceed that which is permitted to the allotment by the plan.

It is important to stress that an allotment should not be seen to be inevitably associated with “national coverage” nor with SFN as the only possible network structure. Recent planning for T-DAB has demonstrated that allotments can be an appropriate method for planning small, or even very small, areas.

4.5 Broadcast network coverage

When calculating the coverage of broadcast network, various factors need to be considered. This section introduces the main ones, and discusses the impact they have on the network coverage.

The methods described in this section may be used to calculate the coverage area of DTTB services in the absence of interference, and the reduction in this coverage area due to interference. Calculating the protection margin instead of the wanted field strength takes into account the effect of interference.

The definitions of terms relating to propagation are available in Recommendation ITU-R P.310 [4.13].

Whereas in analogue systems there is a graceful degradation in performance as the edge of coverage area is approached, the “cliff-edge” failure characteristic of digital systems means that even a small mismatch between predictions and measurements can lead to large difference between predicted and actual coverage areas.

For a deepening on prediction methods and planning software, Report ITU-R BT.2137 “Coverage prediction methods and planning software for digital terrestrial television broadcasting (DTTB) networks” [4.14] also provides a brief outline of the results of the comparisons between predicted and measured signal levels as reported by some administrations.

4.5.1 Propagation models

For any assessment of DTTB coverage, a radio-wave propagation model is needed. The choice of model depends on the availability of terrain height data for not only the service area but also the propagation paths between interfering transmitters and the coverage area.

The currently recommended propagation prediction method for DTTB is in Recommendation ITU-R P.1546 [4.15]. The method provides terrestrial point-to-area field strength prediction values based on the statistical analysis of experimental data. Annex 6 of this Recommendation provides the detailed step-by-step procedure to be used in the application of this Recommendation, which is summarized here:

- Firstly, for 1 kW e.r.p. and temperate regions containing cold and warm seas⁹, a set of field strength values exceeded for 50%, 10% and 1% of time and at 50% of locations within any area of typically 500 m by 500 m are provided in graphical format and also in computer-based tabulations. These are given for certain nominal frequencies, for a set of transmitting antenna heights and certain receiving antenna heights, and for both land and sea path scenarios.
- Secondly, general procedures for interpolation, extrapolation and correction allow field strength prediction calculation along mixed land/sea paths and at other frequencies; for other antenna heights, percentage times, percentage locations and area sizes, and for other climatic regions. The input parameters and their limits for the validity of the method are listed in Annex 6, Table 4 of [4.15] so that predictions can be made for the following parameter ranges:
 - frequency range 30-3 000 MHz;
 - path distance 1-1 000 km;
 - percentage time 1-50%;
 - percentage location 1-99%
 - effective transmitting heights up to 3 000 m.

Location variability refers to the spatial statistics of local ground cover variations and not to entire path variations nor to multipath variations. The method can be used with or without a terrain height database. If such data are available, corrections for tropospheric scattering and for different types of local clutter surrounding the receiving location, including for short urban/suburban paths, can be calculated and increased prediction accuracy would be expected.

- Finally, Annex 5, section 17 of [4.15] gives a method for converting from the field strength calculated for 1 kW e.r.p. to the equivalent basic transmission loss.

⁹ Information on cold sea/warm sea divisions can be found in Recommendation ITU-R P.620 [4.16].

In order to improve prediction accuracy, in cases where terrain height data are available, the method in Recommendation ITU-R P.1812 [4.17] can be used instead of [4.15]. This is summarized here:

- First, the basic transmission loss, not exceeded for the required annual time percentage, $p\%$, and 50% of locations within any area of typically 500 m by 500 m is evaluated as described in Annex 1, section 4.2-4.6 of [4.17] (i.e. the basic transmission losses due to line-of-sight propagation, propagation by diffraction, propagation by tropospheric scatter, propagation by ducting/layer reflection and the combination of these propagation mechanisms).
- Secondly, in Annex 1, section 4.7-4.10 of [4.17], procedures to account for the inclusion of terminal clutter effects (in rural and urban areas), the effects of location variability and building entry loss are described. The procedures are more accurate than the ones in [4.15] and they are based on terrain height data. It is necessary to carry out a path profile analysis in order to derive the parameters indicated in Annex 1, Table 4 of [4.17]. The path profile is constructed from terrain height data following the procedure explained in Annex 1, Attachment 1 of [4.17]. The propagation method is path specific so point-to-area predictions using this method consist of a series of many point-to-point predictions where reception locations are uniformly distributed over notional coverage areas. The number of points should be large enough to ensure accurate characterization of the path variation in the service area. For most practical applications of this method this assumption implies the availability of a digital terrain elevation database, referenced to latitude and longitude with respect to a consistent geodetic datum. In Recommendation ITU-R P.1058 Annex 1 [4.18] guidance on the type of information that should be contained within topographic databases (terrain height and building layout) is provided. The other input parameters and their limits for the validity of the method are listed in Annex 1, Table 1 of [4.17]. Diffraction loss is calculated by a method based on the Deygout construction taken over from Recommendation ITU-R P.452 [4.19]. This method has been found to have limitations. For further information on diffraction see Recommendation ITU-R P.526 [4.20].
- Finally, Annex 1, section 4.11 of [4.17] gives expressions that relate the basic transmission loss to the field strength calculated for 1 kW e.r.p.

Both methods provide location variability corrections that refer to the spatial statistics of local ground cover variations which approximately follow a log-normal distribution [4.15], [4.17]. Neither of them takes into account multipath variations due to local reflections and refractions, which should be considered in mobile and portable reception. The impact of these effects will vary with systems, being dependent on bandwidths, modulations and coding schemes. Guidance on the modelling of these fast fading effects is given in Recommendation ITU-R P.1406 [4.21], Annex 1, section 3. In addition, slower fading due to changes in shadowing to the receiver is more accurately studied than in [4.15] and [4.17]. A measurement-based statistical estimate of path loss due to shadowing is provided for large rural and urban areas as well as for small areas, i.e. local ground cover. In both cases, the estimate follows a log-normal distribution. In [4.21] Annex 1, section 4, calculation procedures of delay spread due to short distant and long distant scatterers, are given based on channel impulse response (CIR) analysis. In Annex 1, section 5.1, guidance on depolarization effect values and time and frequency variation is given. In Annex 1, section 5.2, negative height gain effects due to antenna location are described. In Annex 1, section 5.4, the mismatches between the theoretical mobile antenna gain and the measured one are described.

Land cover attenuation can be more accurately calculated by means of additional corrections due to attenuation caused by vegetation (especially trees) such as the ones available in Recommendation ITU-R P.833 [4.22].

For the variation of building entry loss due to different building materials and the multipath effects due to buildings see Recommendation ITU-R P.1238 [4.23].

The former Recommendation ITU-R P.370 [4.24] is now suppressed, and must be replaced in propagation studies by the methods examined in this section. Note that the GE-89 Agreement [4.25] is still in force in some countries in some frequency bands¹⁰. Except in those countries and bands, where the propagation curves given in the Agreement still apply, the propagation methods in this section should be used.

To sum up, the recommended field strength prediction methods for DTTB are three complementary ITU-R Recommendations: [4.15], [4.17] and [4.21]. Nevertheless, there are other methods that can be used in specific situations:

- The **Okumura-Hata** method in urban environment is described in [4.15], Annex 8 where a comparison with the recommended method is carried out. This method is best suited for urban cell coverage calculations in mobile radiocommunication applications, though it has been extended to suburban and rural areas. Predictions can be made for the following parameter ranges: frequency 100-1 500 MHz; path distance up to 20 km, extended to 100 km; transmitting antenna height 30-200 m; receiving antenna height 1-10 m. This method does not make use of terrain data, and it only takes into account the transmitting antenna effective height and the receiving antenna height above ground.
- The **Cost-231** (or **Cost-Hata**) method is the extended version of Okumura-Hata method for frequencies up to 2 000 MHz. In addition, the model is restricted to situations where transmitting antenna is above the rooftops of nearby buildings. It also allows lower mobile antenna heights than Okumura-Hata.
- The **Cost-231 Walfish-Ikegami** method is best suited for urban cell coverage calculations in which building height and layout data are available in order to calculate “street-canyon” propagation more accurately.
- The **Longley-Rice Irregular Terrain** method (ITM) is used for predicting the attenuation of radio signals for a link in the frequency range of 20 MHz to 20 GHz. This method was created for the needs of frequency planning in television broadcasting in the United States in the 1960s and is still used by the Federal Communications Commission for that purpose. It develops the attenuation relative to free space using the terrain profiles as a function of range that explicitly accounts for three principal propagation mechanisms: line-of-sight (with, possibly diffuse, ground reflection), terrain diffraction and troposcatter. Anomalous propagation, due to ducting/layer reflection and other rarely occurring phenomena are indirectly accounted for via radio climate and time variability specifications. Since it is an empirical model, the desired attenuation for the actual path length, considering the (user) specified quantiles of time, locations and situations (i.e. confidence), is obtained from a fitting method, which is based upon the empirically observed standard deviations from the predicted median reference attenuation. See [4.26] for more details.

There are software implementations for most of the proposed methods. Some of them are free as they have been made available by some Administrations.

Experiences from various countries, including national planning tools introduced in to minimise the error in planning models, is presented in Report ITU-R BT.2137 [4.14].

In order to complete the coverage calculation, some practical aspects should be taken into consideration as regards field strength prediction:

- **Antennas:** Transmitting antenna characteristics at VHF and UHF are defined in Recommendation ITU-R BS.1195 [4.27]. Fixed reception antenna diagrams to be assumed are defined in Recommendation ITU-R BT.419 [4.28] and in Recommendation ITU-R BS.599 [4.29] for the VHF band. As for portable and mobile receivers, antenna gain typical values are provided in Recommendation ITU-R BT.1368 [4.30], Annex 5, section 4.

¹⁰ GE-89 is still in force for the band 47-68 MHz (the Plan is limited to the band 54-68 MHz in the following countries: Botswana, Burundi, Lesotho, Malawi, Namibia, Rwanda, South Africa, Swaziland, Zaire, Zambia and Zimbabwe); and for the bands 230-238 MHz and 246-254 MHz for the countries listed in No. 5.252 of the Radio Regulations.

- **Requirements:** (treated in depth in Recommendations ITU-R BT.1368 [4.30] and in ITU-R BT.2033 [4.31])
- Minimum Usable Field Strength (MUFS) and C/N . MUFS values of ATSC DTV, DVB-T, DTMB and ISDB-T fixed reception systems are available in [4.30] and for DVB-T2, in [4.31]. C/N values of DVB-H and ISDB-T hand held systems for both outdoor and indoor portable reception and for mobile reception are also provided in [4.30]. The S/N values provided by Recommendation ITU-R BS.1114 [4.32] can be useful for T-DMB¹¹ systems.
 - Protection Ratios for digital or analogue wanted signals interfered with digital or analogue unwanted signals are available in [4.30] for the ATSC DTV, DVB-T, DTMB and ISDB-T systems and in [4.31] for the DVB-T2 system. The result “Coverage Probability” has therefore to combine two probabilities: the probability that a certain field-strength of the (combined) useful signal is exceeded, and the probability that a certain required C/I , taking into account all interferers, is exceeded. Due to field strength time variation, in some cases, the risk of interference has to be accepted for a defined percentage of time at various intended receiving locations.
 - Multipath. Digital systems implement mechanisms to cope with delay spread. Nevertheless, if the delay spread values exceed the symbol duration, inter-symbol interference occurs which can lead to higher bit error ratios. On the other hand, local reflections can also have the beneficial effect of filling in deep shadows to some degree, and the systems are designed to tolerate short-delay reflections.
 - Doppler Spread threshold values can lead to speed limitations of mobile receivers within the coverage area in order to have good reception.

4.5.2 The interdependence between transmitting sites and system variant

Digital terrestrial broadcasting deployment can use existing sites, new sites, or a combination of both. These are, to some degree, dependent on the choice of digital terrestrial broadcasting variant and the frequency band to be used. In some countries, it is intended to use the same sites as analogue for digital, which will have some impact on the system variants that can successfully be deployed. In other countries, in contrast, operators might choose to take advantage of the OFDM for new types of services such as portable indoor coverage, but this may also have an impact on the site infrastructure that has to be used.

Therefore, the separation distances between transmitter sites, and hence the number of sites required, will vary from country to country and will depend on the system variant, the reception mode (fixed, portable or mobile), the country size and boundary situations. For digital terrestrial broadcasting, the separation distance between transmitter sites may vary from under 30 km to up 125 km.

In an SFN (see section 4.7) using appropriate digital terrestrial broadcasting standards, the separation distance between transmitters influences the choice of guard interval, which in turn limits the maximum size of the network. The separation distance and the effective height influence the effective radiated power (e.r.p.). Conversely, if a certain maximum guard interval is required (for example, to maximize data capacity), this will impact on the largest transmitter separation distance possible.

In the case of SFNs, the use of “dense networks” can offer some advantages over networks based on high power transmitters separated by large distances (say, over 60 km). Particularly in the case of regional SFNs, but also for national SFNs, it is possible to consider various forms of dense networks, with all of the transmitters using the same channel, but having significantly lower e.r.p. than that required by a single transmitter serving the same area. For digital terrestrial broadcasting, the concept of “distributed emission” can provide the needed field strength over the entire service area by a number of low-power, synchronized SFN transmitters, located on a more-or-less regular lattice, or to use on-channel repeaters receiving their signal off-air from the main transmitter, to improve the coverage of the main transmitter. In the latter case, the repeaters do not need any further time synchronization, and no parallel primary distribution infrastructure is needed to bring the signal to these on-channel repeaters.

¹¹ T-DMB is a video variant of T-DAB.

Furthermore, local high density SFNs could be used to supplement large SFNs in areas where the coverage would otherwise be inadequate, perhaps due to the terrain or to building clutter. Finally, they offer a reduction of the impact of co-channel interference at the border of the service area, by introducing a sharper field strength roll-off. This can be further improved by a suitable exploitation of the transmitting antenna directivity.

For example, it is possible to envisage transmitter topologies in which the central part of the service area is covered by a large SFN (with high power transmitters separated by large distances), but near the border a denser transmitter network is installed (with low e.r.p., and with low-height and directive antennas). This allows the e.r.p. to be “tailored” according to the service area contour, reducing the interference to adjacent areas and keeping the service availability high inside the wanted area. This technique can be useful also on the borders between national SFNs.

4.5.3 Transmitting antenna radiation patterns

Transmitting antennas will have an omnidirectional or directional pattern. For the stations located along country borders or stations located on coastlines, or close to them, directional antennas should preferably be used to reduce interference outside the intended service areas. This will reduce the reuse distance for the frequencies in question, and protect coverage areas of other television stations. This is especially true for high and medium power stations and will in general result in a more efficient use of the frequency spectrum.

Beam-tilt, applied to antennas with an effective height of more than 100 m, is an efficient tool to target the radiated power of high power stations to the outer part of the coverage area and, at the same time, reduces the interference potential at large distances and to the aeronautical service.

4.5.4 Factors influencing the frequency separation distance

The frequency separation distance has a significant influence on the number of frequency blocks or channels needed to establish coverage of a larger area containing several countries or regions, each having its own programmes transmitted in one frequency block or channel.

Coverage areas served by transmitters located along the periphery and using directional antennas pointing inwards (that is, in a closed network) will result in somewhat shorter frequency separation distances compared to equivalent coverage achieved by the use of non-directional antennas (that is, in an open network). In the case of propagation paths with a significant amount of sea, separation distances will be larger than for the case of land-only paths.

4.5.5 Channel models

Electromagnetic waves propagate through a medium that shows random variations of its physical properties, and the signals may experience multipath and fading phenomena, whereby the received field strength in a service area has time and space fluctuations, that can be described by different statistical distributions.

Gaussian: In this channel model, only white Gaussian noise (AWGN) is added to the signal, and there is only one path. The statistical behaviour of this type of channel is characterized in Recommendation ITU-R P.1057 [4.33].

Log-normal: This is the distribution of a positive variable whose logarithm has a Gaussian distribution. Unlike the Gaussian distribution, a log-normal distribution is extremely asymmetrical. The log-normal distribution is very often found in connection with propagation, mainly for quantities associated either with a power or field-strength level or a time. Power or field-strength levels are generally only expressed in decibels so that sometimes reference is made to a log-normal distribution simply as a normal distribution. This usage is not recommended. In the case of time (for example fading durations), the log-normal distribution is always used explicitly because the natural variable is the second or the minute and not their logarithm. This distribution is described in [4.33].

Rayleigh: When the signal is the sum of many independently fading components due to multipath, it can be represented by the Rayleigh distribution [4.33]. Such a channel would be typical for a mobile service operating in a cluttered urban environment, with no line-of-sight to the transmitter or for portable indoor or outdoor reception conditions.

Ricean: A Ricean channel is used to describe the fixed, outdoor rooftop-antenna reception conditions in a cluttered urban environment. It is associated with the situation where one of the components of the received signal, such as that associated with a line-of-sight path to the transmitter, has a power that is constant on the timescale of the multipath fading. In other words, this model is appropriate for signals that have a deterministic component and several random components. A typical scenario might be for point-to-point links, where the overall signal fading can be modelled by the Nakagami-Rice distribution [4.33].

Pedestrian Indoor (PI) and *Pedestrian Outdoor (PO)* have been created to describe hand held reception and are defined in [4.30].

Diversity channel models: MISO channel, MISO Rayleigh channel and Ricean MISO channel are used for second generation DTTB systems that implement diversity techniques at the transmitter.

A Channel Impulse Response (CIR) of a certain channel model can be statistically defined by means of the amplitudes and time delays of the arriving signals at the receiver. Several parameters describing the propagation channel can be extracted from the CIR, see Recommendation ITU-R P.1407 [4.34]. For high-data rate systems, a more detailed knowledge of the CIR may be necessary which incorporates ray-tracing or ray-launching techniques in conjunction with the application of high-resolution building data.

4.5.6 Minimum carrier to noise ratio and protection ratio

4.5.6.1 General

Frequency planning for the introduction of a new broadcasting service is based on two main parameters of the transmission system: the minimum carrier-to-noise ratio C/N_{\min} and the protection ratio PR needed to achieve a given quality target for the delivered service. C/N_{\min} indicates the amount by which a wanted signal level C must exceed the noise level N in order to achieve reception at the intended quality. PR describes the amount by which a wanted signal level C must exceed an interfering signal I in order to achieve reception at the intended quality. $(C/N)_{\min}$ is also termed ‘required C/N ’ or sometimes, just ‘ C/N ’. In the latter case, the exact meaning has to be concluded from the context.

The introduction of digital broadcasting television systems implies some reconsideration of the planning procedures, in order to take into account the different behaviour of these systems and requires some clarification in the interpretation of these two relevant parameters.

4.5.6.2 Dependence on the transmission channel

The characteristics of the terrestrial transmission channel are random variables depending on the receiving location, on the receiving antenna and also on time. In fact, the number of echoes, their amplitudes, delays and phases vary from place to place (and from time to time). Therefore, at each location the frequency response of the channel is different. Even when the echo delays are within the guard interval, the input C/N required by the system depends on the channel characteristics. The presence of echoes produces frequency selective attenuations (notches) within the signal bandwidth, whose depths depend on the echo amplitude. The reason for the system sensitivity to the channel characteristics is due to the fact that the notches heavily attenuate some OFDM carriers (while the noise level remains constant), increasing their un-coded BER. The use of powerful inner codes (e.g. coding rates 1/2, 2/3 or 3/4) allows good recovery of the information of the attenuated carriers by means of the information carried by the other carriers. Therefore, the use of these coding rates reduces the system sensitivity to the channel characteristics. The noise margin loss between the Gaussian channel and the Rayleigh channel can be between 2 to 9 dB, depending on the echo characteristics and on the inner coding rate.

OFDM can exploit the power of multiple echoes in the sense that the available C/N at the receiver input increases, due to power summation of the C contributions, but at the same time the receiver performance can degrade (increase of the required C/N). As a result of these two effects, there can be a net performance gain or loss with multipath reception and SFN contributions. Apart from the low coding rate modes (e.g. coding rate 1/2), a single line-of-sight contribution (Gaussian channel) can give a better global performance than two 0-dB echoes (Rayleigh channel). Conversely, when the number of 0-dB echoes is larger than two, the required C/N does not increase further, and the global performance improves according to the growth of the available C/N . Similar considerations apply to the interference from an unwanted signal, i.e. to the protection ratio PR.

4.5.7 Definition of coverage

4.5.7.1 General

The main questions when building new digital terrestrial networks are the evaluation of the service area and the population covered. These evaluations are made through the estimation of the level of the wanted signal(s) and the level of the interfering signals. The relevant planning parameters in this context are the required carrier-to-noise ratio and the protection ratio, which describe the sensitivity of the system under consideration against noise and against interference.

It is known that once the level of signal decreases and the carrier-to-noise ratio (C/N) or the carrier-to-interference ratio (C/I) has fallen below a given minimum value, the picture can disappear completely with a further signal level reduction of less than about 1 dB. This behaviour is generally referred to as the “rapid failure characteristic of the digital system” and the limit value of the field strength is designated as the minimum required field strength. If the same coverage definition as for analogue television were used for digital television, this would mean that 50% of the locations would not be served at or near the edge¹² of the service area or in any other areas of reduced signal caused by local obstructions. Therefore, as only 50% of locations receiving a picture is clearly unacceptable, higher values of the percentage of locations have to be selected in order to allow reception in a satisfactory number of locations, with a standard receiving installation. Values ranging from 70 to 99% are usually quoted for digital television transmissions.

The exact value chosen depends on the level of service quality which is aimed at, and that is why values can be different from one country to another or even from one broadcaster to another within a given country. Nevertheless, values of 70%, 95% and 99% of the percentage of locations have been chosen in the proposed coverage definitions.

Under such considerations, some of the simpler tools used for analogue television coverage evaluations are not completely satisfactory and it is necessary to make more complex calculations.

In general, the reception of digital services is faced with a multi-signal environment, with multiple interferers as well as multiple wanted signals in the case of SFN. To assess the wanted and unwanted resultant field strengths the individual signals have to be combined. Since signal strengths are described by statistical quantities, they have to be combined statistically.

Basically, this is true for both location and time statistics. However, it is usual to treat them in different ways. Time statistics are taken account of by using tabulated field strength propagation curves for the appropriate time percentages. Location statistics are dealt with by using field strength distributions.

4.5.7.2 Location statistics

4.5.7.2.1 Coverage of a single receiving location

For a receiving location to be covered by a digital broadcast service, we know that the level C of the wanted signal, expressed in dB, has to be higher than the level N of noise by a certain value which is the minimum C/N_{\min} . This can be expressed (in dB) by the condition:

$$C > C/N_{\min} + N$$

In the same way, to overcome the effect of an interferer, the level C of the wanted signal must be higher than the level I of this interferer by a certain value referred to as the protection ratio PR for this particular type of interferer. It can also be expressed (in dB) by:

$$C > PR + I$$

¹² The term “edge” is taken to mean any transition between a covered area and a non-covered area. These “edges” may occur at the outer boundary of a coverage area or at the boundaries of any uncovered area that may exist inside the overall area, usually as result of local obstruction on the path of the wanted signal.

The sum $PR + I$ (protection ratio + field strength of interferer) is often referred to as the nuisance field. In practice, the receiving antenna discrimination against the interfering signal may also need to be taken into account:

$$C > PR + I - Ad$$

with Ad being the receiving antenna discrimination in the azimuth of the interferer.

In practice, the wanted signal has to fulfil both conditions which can be expressed as:

$$C > C/N_{\min} + N + PR + I - Ad$$

For the case where more than one wanted and more than one unwanted signal is encountered, the condition for reception can be expressed as:

$$\Sigma PC > P(N + C/N_{\min}) + \Sigma P(PR+I-Ad)$$

where:

- ΣPC : summed power of the wanted signals
- $P(N + C/N_{\min})$: noise power equivalent + required C/N
- $\Sigma P(PR+I-Ad)$: summed power of the nuisance fields.

4.5.7.2.2 Coverage of a small area

In practice, it is not possible to know the real values of the field strength for each receiving location in order to apply the previous formula and to determine precisely the coverage area. The only figures that can be evaluated are the mean values of the field strengths in small areas (typically, 100 m × 100 m). The variation over such a small area is often called long-term fading, or shadow fading.

The problem is then to know if a given small area is inside or outside a coverage area and to calculate the probability of good reception in these areas. This probability represents the percentage of receiving locations that can receive a satisfactory signal (that is, those where the wanted power is greater than or equal to the sum of the noise and nuisance powers) within the small area. A small area is regarded as covered – and thus as belonging to the coverage area – if the probability is higher than a given threshold, e.g. 70%, 90% or 95%. This aspect is discussed more detail below.

The calculation of the probability is carried out – using the appropriate values for the noise level and the protection ratios of each type of interferer – for the field strengths, which are random variables. The field strength prediction gives the mean level of the wanted field strengths and of the unwanted signals using the prediction method of, for example, Recommendation ITU-R P.1546 [4.15] or prediction models using terrain data banks.

But, because the wanted and nuisance powers are random variables which are only known through their mean and standard deviation, the formulas given in the previous section cannot be applied only to the means of the wanted and nuisance powers. It is necessary to refer to mathematical models for the distribution of field strength with locations and to use mathematical methods to obtain the result of the combination of several randomly distributed signals. This is dealt with in more detail below.

A further aspect that has to be mentioned in this context is the fact that each propagation model is affected with a prediction error which adds a further statistical component. The prediction error varies from one individual propagation model to the next. Often shadow fading and prediction error are dealt with together, and it is assumed that the applied standard deviation of the field strength covers both effects.

4.5.7.2.3 Propagation prediction and its statistical background

Terrestrial broadcasting signals are propagated through the atmosphere between the transmitter and the receiver. The characteristics of the propagation channel gives rise to a statistical time variation and a statistical location variation of the field strength. The time variation of a wanted field is in general very small compared to its location variation. These statistical variations are incorporated in well-known propagation models such as Recommendation ITU-R P.1546 [4.15].

When discussing the statistics of received field strength, the variation of the wanted signal is determined over a small area where the signal has an average value and a log-normal type of variation around this median value, with a known standard deviation. This value of the standard deviation normally varies between 3 and 6 dB. For planning of digital broadcasting services a value of 5.5 dB is often used. The areas over which this value has validity must have a suitable size. In other words, the area cannot be ‘too large’ or ‘too small’. Typically, it has the size of 100 m × 100 m. A suitably sized area will be termed a ‘Test Area’ or a ‘Pixel’.

As an illustrative counterexample, measurements of the field strength over an area stretching from the transmitter site outward to a concentric circle 100 km away will certainly have a standard deviation more than 5.5 dB. This would not be a test area. Likewise, if the area consists of only few closely located points, the location standard variation will be less than 5.5 dB.

It must be remembered that field strength values provided by statistical propagation models do not give information about specific points, only about test areas. For example, a field strength level, X, may be achieved (or exceeded) at 50% of the locations at a given distance from a transmitter with a given effective antenna height and e.r.p.; another (lower) field strength level, Y, may be achieved (or exceeded) at, for example, 99% of those same locations for the same transmitting conditions. The difference, X–Y, is proportional to the standard deviation, and represents the spread within which most field strength values will lie when measured at the points within the test area. No information is given as to which individual locations/points within the test area receive a field strength equal to a specified field strength level, or which individual locations/points receive a field strength that exceeds the specified field strength level.

If the transmitter power is now increased by a fixed amount (say, 3 dB), then the received field strength will be increased at each location/point by that amount (3 dB) and the field strength at more locations/points than before will equal or exceed the specified field strength level (X or Y). But there is still no knowledge of those specific locations/points where this happens. Nevertheless it makes sense to say that the field strength has been raised by 3 dB at all of the locations/points under consideration or, equivalently, that the specified field strength level (X or Y) is reached or exceeded at a higher percentage of locations/points (higher than 50% or 99%, respectively).

4.5.7.3 Time statistics

Time statistics for interfering fields are taken account of by basing calculations on 1% time propagation curves¹³, whereas wanted field calculations are based on 50% (or 99%) time propagation curves. Normally, a more detailed treatment of time statistics is not performed in coverage calculations for digital broadcasting services. Actually, there are not even methods available to do so. To some extent, this approach is justified – at least for wanted signals – by the fact that for shorter distances (less than 100 km) the time variation is much smaller than the location variation.

With respect to signal summation, self-interference fields are treated as ‘normal’ unwanted signals. 1% time propagation curves are used, and they are added to the other source of possible interference from outside the SFN.

4.5.8 Minimum reception conditions

4.5.8.1 Single signal case

Location statistics of an individual (logarithmically-distributed) field strength originating from one transmitter are described by means of a normal distribution, characterized by two parameters, mean value and standard deviation. Accordingly, the power of the signal is then distributed log-normally.

The key role of coverage probability targets as planning parameters for a digital system has been previously discussed. These target figures are related to the field strength distribution parameters. 50% coverage probability is determined by the mean value of the distribution, for the calculation of higher (and also lower) coverage probabilities both mean value and standard deviation of the signal distribution are needed.

¹³ That is, the interfering field strength, which is exceeded for just 1% of the time.

In the case of a single signal, where the distribution parameters are known from the propagation prediction, probability margins to cater for higher coverage probabilities are easily calculated and the minimum median field strengths for planning can be determined. The same applies to probability margins for protection ratios when one wanted and one unwanted field are involved. The exact definition of protection margin is given later in this chapter.

In section 4.5.7.2 the general formulation of the minimum reception conditions is given. In the case of a single wanted signal and a single unwanted signal, this is (neglecting receiving antenna discrimination for simplicity):

$$C > C/N_{\min} + N + PR + I$$

In the absence of the interferer, the minimum field strength F_{\min} is defined as:

$$F_{\min} = C/N_{\min} + N$$

For proper reception, F_{\min} must be exceeded by the wanted signal C , which – as a statistical variable with a normal distribution – is described by a mean value C_{mean} and a standard deviation σC :

$$C > F_{\min}$$

or, to be more precise:

$$P(C > F_{\min}) > p$$

where $P(A)$ denotes the probability of the event A and p the intended location coverage probability. With the given distribution parameters of C and the intended coverage probability p the minimum median equivalent field strength for planning ($FMME$) can be evaluated:

$$FMME = F_{\min} + (\mu p * \sigma C)$$

$FMME$ is the planning parameter that must be exceeded by the mean value C_{mean} of the wanted signal C in order to guarantee proper reception with the intended coverage probability. The amount $\mu p * \sigma C$ by which $FMME$ is larger than F_{\min} is called the probability margin. It is a function of the standard deviation and of the percentile factor μp . Values of μp for typical coverage probabilities p are given in Table 4.1 below. Often the probability margin is also called propagation margin.

TABLE 4.1

Percentile factors for typical probabilities p

p	μp
0.50	0.00
0.70	0.52
0.95	1.64
0.99	2.33

A similar consideration holds when the interference of the wanted signal (with level C) by an unwanted signal (with level I) is examined. For proper reception, the wanted signal has to fulfil the condition:

$$C > PR + I$$

or, again in statistical form:

$$P(C > PR + I) > p$$

The evaluation of this expression renders the condition for the mean value C_{mean} of the wanted field:

$$C_{\text{mean}} > I_{\text{mean}} + PR + \mu p * \sqrt{(\sigma_C^2 + \sigma_I^2)}$$

The probability margin $\mu p * \sqrt{(\sigma_C^2 + \sigma_I^2)}$ now contains both standard deviations of the wanted as well as of the unwanted signal since both are statistical variables. The probability margin reduces to the form $\sqrt{2} * \mu p * \sigma$, when the same standard deviations are assumed for the wanted and the unwanted signal, that is, where $\sigma_C = \sigma_I = \sigma$.

Since the standard deviations of the wanted and the unwanted field are known (they are output parameters of the field strength prediction model), in the single signal case the probability margins can be calculated and be used as generally valid planning parameters.

The combined treatment of noise and interferer, as already indicated in section 4.5.7.2.1, contains elements of statistical summation and is therefore discussed in the next chapter.

4.5.8.2 Multiple signal case

In principle, the same minimum reception conditions as described in the previous chapter also apply in the case of a multiple signal environment. However, the fact that statistical sums of the wanted signals and of the unwanted signals are now involved makes the evaluation of coverage more complex. Multiple interfering signal configurations are well known in many broadcasting situations, whereas multiple wanted signals are a particular aspect of single frequency networks.

When a multi-signal situation is encountered, the parameters of the resulting signal distribution are no longer known a priori. Mean value and, especially, standard deviation strongly depend on the particular combination of signals being considered. As a consequence, minimum field strengths and probability margins no longer have fixed values; they rather become variables depending on the number, strength and spread of the individual single field strengths. However, two general trends can be identified. Firstly, the mean value of the composite signal is larger than the arithmetic sum of the individual means and, secondly, the standard deviation of the composite signal is smaller than that of the individual signals. In the case of wanted signals, these two facts create the effect known as “network gain”.

The following example may give an impression of the significance of field strength summation effects. Maximum statistical network gain is achieved if the contributing fields are of equal strength at the receiving location. In the case of, e.g. three single signals it amounts to about 6 dB and lowers the minimum median field strength for planning at that location by this amount. If the three signals are not of equal strength network gain varies between 0 and 6 dB. In a similar way probability margins for protection ratios are reduced by signal summation effects. The example shows that signal summation effects in SFN may impact the coverage of a digital service to a significant amount.

It has already been stated that signal summation effects increase the mean value and lower the standard deviation of the resulting sum signal distribution as compared to the outcome of a non-statistical treatment. This is an important finding, since it gives the possibility to fix the results of the non-statistical treatment as an upper bound for initial planning estimates. Allowing for some additional implementation margin, they form an appropriate basis for planning when detailed information about the transmitter characteristics of a network is not available, e.g. when setting up an allotment plan.

On the other hand, detailed planning, e.g. for the implementation of a real transmitter network, has to take account of signal summation effects. Probability margins for minimum field strengths and protection ratios then no longer form suitable planning parameters. They have to be replaced by the more basic coverage probability targets.

Since network gain is a fundamental feature of single-frequency networks this aspect is discussed in greater detail in section 4.7.

4.6 Network planning in MFN

A Multi-Frequency Network (MFN) is a network which assigns a different frequency for each transmitter, i.e. for N transmitters, N frequency channels are used. The use of multiple frequencies avoids unacceptable co-channel interference among the transmitters, although in most practical networks there will be insufficient frequency channels to use each only once, so in general, frequencies are reused at a sufficient distance not to cause unacceptable interference (see Figure 4.1).

FIGURE 4.1
Multi-Frequency Network (MFN)

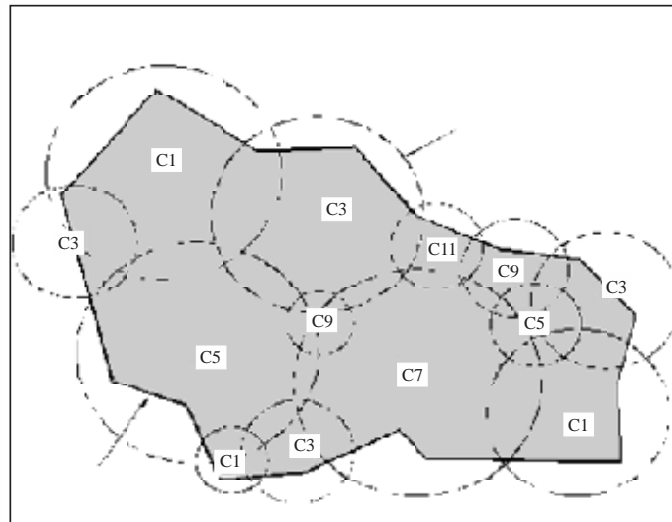

DTTB-04-01

The ATSC system, which has been adopted in the US, Canada, the Republic of Korea and Mexico, is the only single-carrier system described in Recommendation ITU-R BT.1306 [4.2], and is generally implemented as a MFN. ATSC v3.0 uses multi-carrier technology, so this restriction is removed.

The MFN concept may also be used for multi-carrier DTTB systems, such as DVB or ISDB. It may be particularly useful during the transition from analogue to digital broadcasting as a large part of the existing analogue network infrastructure may also be reused, particularly for fixed reception, permitting viewers to reuse their existing receiving antenna and feeder system. During the transition period of coexistence of analogue and digital services, and especially at the first introduction of digital services, it may be important not to place unnecessary implementation burdens on viewers.

MFN planning is useful in this case because of the inherent assumption that an existing analogue service, which may serve a very large proportion of the population in a country, will remain in use for some years and that relatively few changes to the analogue stations will occur during that time. In particular, there are likely to be no widespread channel or site changes within the analogue networks. The new DTTB networks, therefore, will need to be interleaved amongst the analogue channels during the transition period. Nevertheless, it may be desirable to introduce a limited number of channel changes, or even site changes, at some analogue stations which may otherwise have a significant negative impact on the implementation opportunities for digital stations and services.

Some MFNs, consisting of higher power main stations only, may not provide complete coverage. Lower power repeater stations (gap-fillers) could complete the coverage using the same frequency as the associated main station (as part of a Single Frequency Network, SFN) or as separate assignments in an MFN. The SFN is an option that may aid in the replication of the analogue network architecture.

An advantage of the MFN is the easy construction of networks because there is no need for synchronisation among the digital transmitters (necessary in an SFN) which may therefore reduce the equipment and budget for construction. Another benefit is that it may be easier to find a number of available frequencies for an MFN during the simulcast period of analogue and digital television than to find a frequency suitable for wide-area SFN use.

4.6.1 Procedures of planning

Step 1: Identification of wanted service area

It is very important to decide the wanted service area for the DTTB system. It is common that the service area for DTTB will be the same as the area covered by the analogue TV broadcast system. An advantage of digital technology is the possibility of reducing the transmitter power up to 16 dB compared with that of analogue transmitters while achieving the same coverage area (depending on the chosen DTTB transmission mode).

Step 2: Reception mode

DTTB systems are designed to be receivable via fixed (rooftop) antennas, or portable receivers, or even on handheld devices. The desired reception mode is probably the most significant driver in frequency planning for DTTB services, so must be considered very early in the process.

Step 3: Planning parameters

Because of the “cliff-edge” failure of DTTB systems (that is, they exhibit a rapid degradation of reception quality at the reception threshold), it is generally necessary to ensure they are available for high percentages of time and location probability. For example, the GE06 Agreement [4.10] assumes that services must be available for more than 99% of the time. The percentage of locations at which the service is to be made available depends on the chosen reception mode.

A minimum usable field strength should then be determined according to the required time and location probabilities, the height of the receiving antenna, and the receiving system characteristics.

The appropriate transmitting power can therefore be calculated to cover the wanted service area with a given transmitter antenna gain.

Within a single frequency channel (which may be 6, 7 or 8 MHz wide), DTTB systems can provide data rates from 4 to 40 Mbit/s, depending on the chosen reception mode and other parameters. In general, wider bandwidths provide for higher data rates.

Section 4.8 expands on the choice of transmission parameters.

These are given in Recommendation ITU-R BT.1306 [4.2] for first generation systems and in Recommendation ITU-R BT.1877 [4.3] for second generation systems.

Step 4: Frequency assignment

Given the choice of reception mode, and required data rate, the protection ratio required by the receiver can be established.

A candidate frequency can then be tested to ensure that for any point in the service area, the receiver’s protection ratio exceeds the ratios between wanted and unwanted signals (C/I), and that the new transmitter does not cause unacceptable loss of service to other transmitters. If these criteria are met, then the candidate frequency may be suitable for use at that site.

If not, the calculations should be repeated using an alternative frequency or a modification of the transmitter parameters until the protection ratio criteria are met.

Note that it may not be possible to provide the required coverage at every point in a service area, or to entirely eliminate interference to other existing transmitters. In this case, after examination of alternative frequencies and transmission parameters, it may be necessary to consider using a sub-optimal frequency allocation.

Step 5: Coordination

Once the interference caused to and from a new transmitter is understood, coordination between DTTB transmitters may be required to reduce unacceptable interference. This may result in modification of the transmitting power, antenna gains, radiation patterns and/or possible relocation of the transmitter.

Sometimes coordination between two or more countries may be needed. Chapter 6 of this Handbook expands on the international coordination process.

Step 6: Gap-filling

Even though transmitters are constructed at high elevation sites for wide coverage, uncovered areas may still exist. In addition, there may not be enough field strength from a main transmitter for the DTTB signal to be received indoors or underground. These shadow areas can be covered with low power gap-fillers. It may be possible to find appropriate frequencies in a MFN system to cover the small shadow areas, since gap-fillers are less likely to cause harmful interference if low-power and low-height transmitters are used.

4.6.2 Planning parameters

4.6.2.1 Reference receiving system for frequency planning

The characteristics of a reference receiving system for digital terrestrial television systems are the basis for frequency planning of digital terrestrial television services in the VHF/UHF bands. Such characteristics for first and second generation DTTB systems are defined in Recommendation ITU-R BT.2036 [4.35].

All receiver characteristics for frequency planning are divided in two categories:

- common receiver characteristics applicable to any digital terrestrial television system;
- receiver characteristics applicable to a specific digital terrestrial television system.

Common receiver characteristics include the following:

- receiver antenna height above ground (e.g. 1.5 m for portable and 10 m for fixed roof top reception);
- receiving antenna directivity (see Recommendation ITU-R BT.419 [4.28]);
- receiver noise figure (depending on frequency – from 6 to 10 dB, see Recommendation ITU-R BT.2036 [4.35]);
- antenna gain (depending on frequency – from 4 to 12 dB, see Recommendation ITU-R BT.2036 [4.35]);
- feeder loss (depending on frequency – from 1 to 5 dB, see Recommendation ITU-R BT.2036 [4.35]).

Specific receiver characteristics are defined for first generation DTTB systems (DVB-T, ATSC, ISDB-T) and for second generation DTTB system (DVB-T2 in Recommendation ITU-R BT.2036 [4.35]). Note that this Recommendation does not contain receiver characteristics for DTMB systems.

4.6.2.2 Minimum field strengths and Protection ratios

Planning criteria and protection ratios for first generation systems are provided in Recommendation ITU-R BT.1368 [4.30] and for second generation systems in Recommendation ITU-R BT.2033 [4.31]. Protection criteria for terrestrial multimedia broadcasting systems for mobile reception using handheld receivers in VHF/UHF bands are defined in Recommendation ITU-R BT.2052 [4.36].

In Annex 2 to Chapter 4, various implementation scenarios are explored which derive minimum usable field strengths taking into account typical receiving installations.

The defining of protection ratios needs to consider the nature of the interference. Such consolidated information is provided in Report ITU-R BT.2382 [4.37].

4.7 Network planning in SFN

4.7.1 General

Single Frequency Networks (SFNs) provide the required coverage through the use of multiple transmitters operating on the same frequency and carrying the same content. Operation of DTTB networks¹⁴ in a single frequency configuration is facilitated by use of the multi-carrier Orthogonal Frequency Division Multiplexing (OFDM) modulation technique, which enables the reception (and constructive summation) of more than one useful RF signal (multi-path immunity).

In an SFN, many receiving locations within the coverage area could be served by more than one transmitter. Where this occurs it introduces a certain level of redundancy to signal reception and can improve the service availability. The field strength from a single transmitter shows statistical variations due to the presence of obstacles on the propagation path, particularly for portable and mobile reception. This field strength variation can be reduced by the presence of several transmitters, located at different directions as seen from the receiver, since when one source is shadowed, others may be easily receivable. This aspect of an SFN gives rise to “network gain”, which is explored in detail in the subsequent section. An SFN can be designed to provide a more homogeneous field strength distribution throughout its coverage area than a single transmitter covering the same area.

In a single frequency network all transmitters of a network use the same frequency. They possess a common coverage area and cannot be operated independently. This is sketched in Figure 4.2, where an SFN with 10 transmitters operating on channel C1 is described. The Figure shows the service area as well as the common coverage area of the transmitters.

When operating in an SFN, the signals transmitted from individual transmitters should be:

- synchronous in time (or with a precisely controlled delay);
- nominally coherent in frequency (within a few Hz);
- modulated with identical bit-streams.

The network should be designed to minimise self-interference and to make use of the wanted signals produced by other transmitters in the SFN. The delay between signals arriving at the receiver depends on the difference in the length of the propagation paths between the receiver and the various transmitters in the SFN; the delay can be of the order of some tens to some hundreds of microseconds, depending on the transmitter separation distance and on the actual implementation of the individual delays set at each transmitter of the SFN.

¹⁴ Except ATSC. See section 4.6.

FIGURE 4.2
Single Frequency Network (SFN)

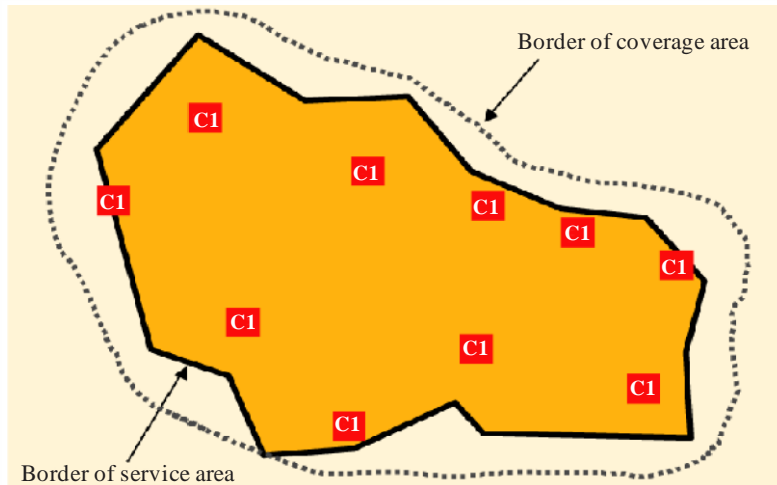

DTTB-04-02

Single frequency networks can be implemented by one of two theoretical types of structure. One is called an “open” and the other a “closed” network. It is assumed that both types of networks are designed to provide the minimum wanted field strength at the boundary of the coverage area:

- In an open network, no measures are taken to minimize the level of radiation towards areas outside the coverage area. In the limiting case, an open network can consist of just a single omni-directional transmitter.
- In a closed network, the level of radiation towards areas outside the coverage area is deliberately reduced without reduction of the coverage of the intended area. This can be done by using directional antennas on transmitting stations near the periphery of the coverage area.

In a real network, covering a large area there could be considerable distances between the transmitters. If such a network is designed as a closed network, it will cause less interference at a given distance outside of its coverage area than if it had been designed as an open network. The reason for this is that the level of interference is mainly determined by the radiated power from the transmitters closest to the boundary of the coverage area in the direction considered.

However, in a closed network covering a small area the radiated power from transmitters on the side of the coverage area opposite to the direction under consideration contributes relatively more to the outgoing interference level than in a closed network covering a large area. Thus, the use of directional transmitting antennas on transmitters near the boundary of a small coverage area consequently brings less advantage than in the case of networks covering larger areas. This can be mitigated, at least in part, by the use of techniques such as beam-tilt.

It follows from the above that for relatively large coverage areas, the separation distance between co-channel areas will generally be less for closed networks than for open ones. For smaller coverage areas, the separation distance for closed networks may approach that for open networks.

Several variants of SFN for providing large area coverage exist, although these differ more in appearance than in reality. The primary difference lies in the spacing between transmitter sites. At one extreme would be a network based on existing sites that may have been or still are used for analogue services, and can be 80 km or more apart. At the other extreme would be a dense network with transmitter spacing of only 10 or 20 km. In practice, any real network is likely to consist of some elements of both of these cases. Even a network based primarily on the existing or former analogue station sites would be likely to need a number of relay stations and these could have relatively small spacing between adjacent sites. Conversely, a dense network is likely to have some “gaps” where the population density is too low to make it economically justifiable to build some stations.

4.7.2 Flexibility in use of spectrum

SFN configuration allows a very large flexibility in the use of spectrum. For example, a network can be initially designed to provide coverage to fixed roof-level antennas, but can be developed later, without the need for additional frequencies, to provide mobile or portable services by the addition of supplementary transmitter stations.

Another flexibility that SFNs bring is the freedom for a broadcasting operator to implement new stations to improve coverage within an existing network, without having to use additional spectrum.

4.7.3 Impact of DTTB system parameters on SFN performance

While on one hand one of the major benefits of SFNs is the improvement of the utilisation of the spectrum and to make spectrum planning less complex, on the other the system and planning parameters must be carefully determined.

In the first instance an appropriate network topology is to be chosen. Two approaches are possible in principle: High-Tower-High-Power (HTHP) or Low-Tower-Low-Power (LTLP), with ranges in between. Normally, for the distribution of broadcast content, an HTHP approach is pragmatic as it would allow existing transmitter site infrastructure to be re-used. Secondly, the intended coverage target and reception mode are to be defined.

These determine the choice of the system parameters which differ between DTTB systems (for details see Chapter 9).

As an example, in the case of a DVB-T2 SFN the first step is to select the length of the guard interval according to the physical size of the SFN or the SFN's intra-transmitter separation distances, noting of course that it may be possible to have larger transmitter separations than the guard interval depending on practical considerations such as terrain, propagation and system robustness, etc. Together with the selection of the length of the guard interval, the guard interval fraction also needs determination. The GI fraction involves consideration of the FFT size which is related to the reception scenario: fixed rooftop, portable or mobile reception. In the case of fixed rooftop reception, it would seem desirable to use a larger FFT as this will reduce the GI fraction and increase the available capacity. For portable and mobile reception a lower FFT size such as 16k, 8k or even 4k may need to be considered, in particular for mobile reception when Doppler is a limitation. The choice of modulation determines the bit rate (capacity), but it also has a large impact upon the robustness of the system; higher order modulation schemes that offer more capacity are more fragile. Additionally, there are several Scattered Pilot Patterns (PP) available in DVB-T2, PP1 to PP8. The choice of pilot patterns will determine the performance for delayed signals arriving outside the guard interval as given by the Nyquist limit. Exceeding this Nyquist limit means that channel equalization is incorrect even if the fraction of inter-symbol interference (ISI) is small (for more details, see Annex 2).

More complete information on SFNs can be found in Report ITU-R BT.2386 – Digital terrestrial broadcasting: Design and implementation of single frequency networks (SFN) [4.38], where many practical examples are also described with the aim of sharing experiences and giving guidance in design and implementation to those have the intention to deploy this kind of network.

4.7.4 Network gain

In an SFN many receiving locations may be covered by more than one transmitter, thus introducing a certain level of redundancy in the signal sources and improving the service availability. This improvement is particularly relevant in portable reception where the field strength from a single transmitter shows statistical variations due to the presence of obstacles on the propagation path. This field strength variation can be reduced by the presence of several transmitters, located in different directions, since when one source is shadowed, others may be easily receivable. This is known as “network gain”. The benefit of network gain for fixed reception, because of the use of directional receive aerials, may be limited, but it can be more significant for portable reception with its non-favourable receiving sites and less elaborate receiving antennas.

As a result of network gain, SFN can be operated at lower powers and the field strength distribution is more homogeneous when compared to that of an MFN. The SFN approach seems to be the most reasonable way to provide satisfactory coverage for larger areas particularly when portable reception is envisaged.

Recommendation ITU-R SM.1875 [4.39] contains the following description of network gain:

“If signals from multiple wanted transmitters inside an SFN can be received within the guard interval, the reception quality can be improved and the minimum wanted field strength from each transmitter can be lower. The network gain, however, is not the sum of the wanted field strengths from all receivable transmitters. It is merely the increased probability to receive a better signal from an additional direction than from a single transmitter alone.

The network gain is the difference of the receiving field strengths inside SFNs and MFNs necessary for the same location probability.

In an SFN, the increased number of transmitters leads to a more homogeneous distribution of the field strength in the coverage area. The standard deviation σ of the field strength values is lower.”

For example: The minimum median field strength E_{med} for a certain system variant is 61.3 dB($\mu\text{V}/\text{m}$). This, as defined, applies to 50% location probability. In an SFN, the minimum wanted field strength E_{min} for 95% location probability is 66.7 dB($\mu\text{V}/\text{m}$), for an MFN it is 70.3 dB($\mu\text{V}/\text{m}$). The network gain is thus 3.6 dB.

4.7.5 Self-interference

The power of all signals in an SFN received within the time width of the guard interval is treated as useful, and contributes to the total available signal power. Outside the guard interval, only a part of the echo power is associated with the same OFDM symbol as the primary signal, and therefore contributes positively to the total useful signal power.

The other part of the echo power is associated with the previous or subsequent OFDM symbol and produces inter-symbol interference. Therefore, as the signal delay is progressively increased beyond the guard interval, the useful contribution decreases and the inter-symbol interference increases.

This gives rise to two restrictions imposed on an SFN. Firstly, for a given receiving location, the main contributing signals generally come from the nearby transmitters. In order to keep these contributions constructive the time delay between them must not exceed the guard interval remarkably, which means that neighbouring transmitters have to keep a certain upper limit for the distance between them.

Secondly, even if the maximum separation distance for neighbouring transmitters is kept, more distant transmitters in the network may contribute destructively. There may be a maximum extension of the SFN area that must not be exceeded in order to keep the number of relevant self-interfering transmitters small.

The significance of self-interference, the resulting maximum separation distance between neighbouring transmitters and whether there is an overall maximum extension of the SFN service area depends on the chosen guard interval, the sensitivity of the system with regard to self-interference, indicated by the relevant C/N value, and the density of the transmitters in the network.

In a large SFN, it may be difficult to plan the network so that signals from transmitters a long distance away from the receiver are always of an insignificant level compared to those from nearby transmitters. This difficulty is increased because

- the signal levels from distant transmitters have to be calculated for small percentages of the time (typically 1%) to ensure that reception is protected for high percentages of the time (typically 99%), and
- the receiving aerial for portable and mobile receivers is non-directional.

In a large SFN it is possible that the propagation delay for signals from distant transmitters may place them outside the guard interval of more local ones. The effect of this can be reduced by either advancing or delaying the transmission time of the service from some transmitters in relation to some fixed reference. For a large, complex SFN, detailed calculation of relative transmitter timing is one tool that can be used to minimize self-interference and therefore to optimize network coverage.

4.7.6 Transmitter synchronization

In order for an SFN to operate correctly, all of the transmitters in the network need to be synchronized with one another. This requirement is true in both the frequency and time domains.

4.7.6.1 Frequency synchronization

The frequency accuracy of the digital transmitter will need to be very stable. To minimize any drift, all transmitters should be locked to a reference source, for instance the time signal of GPS.

4.7.6.2 Timing synchronization

In order to reduce inter-symbol interference it is possible to adjust the time at which a specific signal frame is launched from each transmitter of the network (the relative transmitter timing). Optimizing this delay allows the signals from both near and distant transmitters to arrive at the receiver within the guard interval, thus being constructive rather than destructive. The relative transmitter timing can be adjusted to be either in advance of or after a reference point.

However, in all cases the time of signal transmission at each transmitter of the network needs to be referenced to a time reference. Distribution of the service content also needs to be considered so that the same data frame is transmitted during the same time period, either with or without any required delay. Over a large, e.g. national, network the arrival of the content information to transmitters may vary significantly. One option is to feed the content signal directly to the network sites using satellite distribution. Another is to provide variable buffering on the input to each transmitter, linked to the timing reference.

In a small SFN, i.e. one that is not larger in diameter than the signal can travel in the guard interval, it should not be necessary to consider this element of network planning.

When initially designing the network configuration the planner needs to predict both the wanted coverage and the interference potential of each transmitter. These predictions should be carried out at 50% time for the wanted service and 1% time for the interferer. With the relative timing delay set to zero the coverage of the whole network can be derived. At that point, the overall interference caused by each transmitter into the SFN can then be calculated.

In general it will be the highest power assignments that will cause the most interference and it is reasonable to focus on them initially. However, adjusting the timing of sites with lower e.r.p. can lead to significant coverage gains around the periphery of their service areas.

Once the destructive transmitters have been identified the network timings can be adjusted and the interference recalculated. It should be noted that the transmitter causing the greatest interference may not be the one to adjust since a change may simply cause a problem in a different part of the network. It may be a better strategy to adjust the smaller site(s) so that their signals are received within the guard interval of the distant high power site.

Consideration should also be given to how receiver FFT windowing affects predicted coverage. However, since manufacturers are reluctant to disclose details of how their receivers operate it is difficult to give general guidance. Common synchronization strategies are discussed in [4.40].

When an MPEG-2 transport stream is distributed to a network of transmitters, it is possible to adjust the transport delays by means of an SFN network adapter. As shown in the example given in Figure 4.3, extracted from the ETSI technical specification *TS 101 191 Digital Video Broadcasting (DVB)* [4.41], the objective of the Tx Network adapter is to generate a MPEG-2 Megafame and to insert MIPs (Megafame Identification Packets) which conveys the time offset between the last GPS pulse and the Megafame starting time. The Rx Network adapters search MIP packets and introduce the required delay before delivering the MPEG-2 signal to the OFDM modulator and the secondary distribution network.

FIGURE 4.3

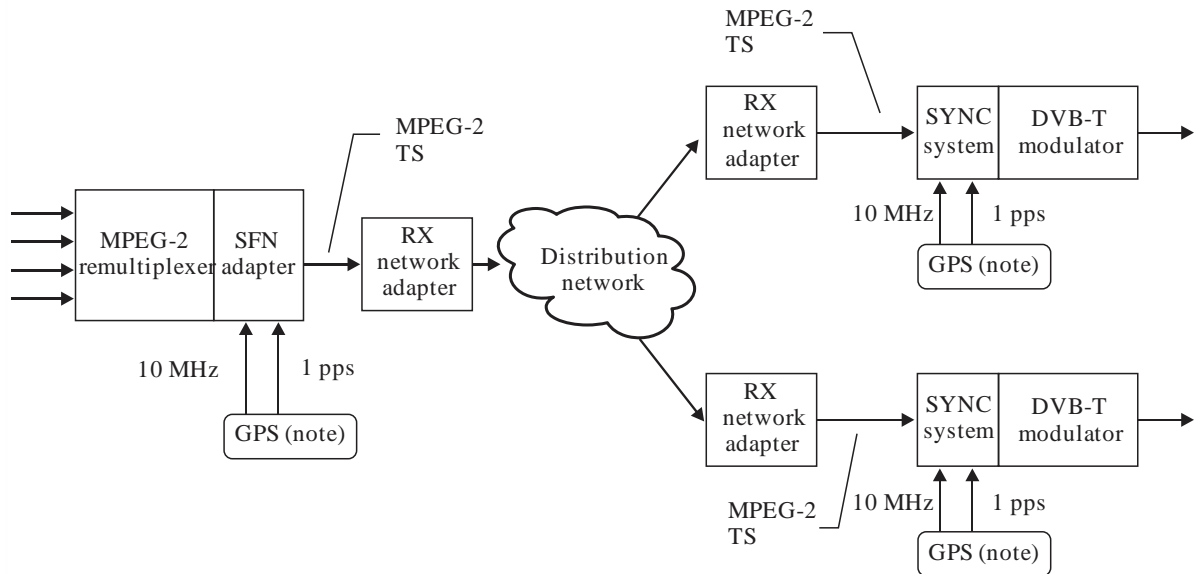
DVB-T SFN distribution with network adapter

DTTB-04-03

4.7.6.3 Effect of synchronization loss

If a transmitter is allowed to drift out of synchronization with the rest of the network, it will become a source of interference to the coverage of the rest of the network. This will be noticeable as an area of lost coverage toward the periphery of the un-synchronized transmitter's service area, a "mush" zone. As the transmitter drifts further out of synchronization with the rest of the network the mush zone will become progressively larger. It should be noted that reception close to the drifting transmitter, where received field strengths are high, are unlikely to be affected. This can make fault-finding difficult when based on viewer reports of disrupted reception.

4.7.7 On-channel repeaters

An on-channel repeater (also known as gap-filler) is a device that receives a terrestrial DTTB transmission at a particular VHF/UHF frequency, amplifies the received channel, and retransmits it on the same frequency. Such a repeater is used to extend the coverage of an existing network through transmissions on a single frequency without the need for additional transmitters. The main benefits of repeaters, when compared to ordinary transmitters, are easier deployment and lower cost.

The delay induced by the whole process of reception, amplification and transmission must be substantially shorter than the guard interval of the DTTB mode used (say, a typical delay is 5 μ s), so that a receiver receiving signals from both a transmitter and from an on-channel repeater does not have to deal with interference, but with constructive addition of signals.

There are, however, obstacles in the deployment of such repeaters. The transmitted signal may be fed back to the input of the repeaters, thus creating a feedback-loop, which generates two kinds of problems: ripple in the transfer function of the device, and, at worst, instability of the device. To overcome these, there must be sufficient isolation between the receiving and transmitting antennas, or some echo-cancellation techniques must be used in the repeater (which increase complexity, and thus the cost).

4.7.8 Choice of system parameters

There is no a unique way of implementing a DTTB network and basically the choice of system parameters depends on the network requirements. Annex 2 to Chapter 4 contains examples of parameters for different implementation scenarios for DVB, ISDB, DTMB and ATSC networks.

Examples of DTTB network implementations can also be found in the following ITU-R documents:

- Report ITU-R BT.2140 – *Transition from analogue to digital terrestrial broadcasting* [4.42]
- Report ITU-R BT.2254 – *Frequency and network planning aspects of DVB-T2* [4.43]
- Report ITU-R BT.2294 – *Construction technique of DTTB relay station network for ISDB-T* [4.44]
- Report ITU-R BT.2343 – *Collection of field trials of UHDTV over DTT networks* [4.45]
- Report ITU-R BT.2385 – *Reducing the environmental impact of terrestrial broadcasting systems* [4.46]
- Report ITU-R BT.2386 – *Digital Terrestrial Broadcasting: Design and implementation of single frequency networks (SFN)* [4.38]

Annex 1 to Chapter 4

Reference Planning Configurations and Reference Networks in the GE06 Agreement

A4.1.1 General

DTT techniques allow for a large variety of implementation configurations. In order to classify such configurations so-called Reference Planning Configurations were defined at the GE06 planning conference¹⁵. These are described in section A4.1.2.

The GE06 Agreement [4.10] foresees the planning of DTT implementations on the basis of allotment plan entries and assignment plan entries. Allotments and assignments are described in more detail in sections 4.2.6 and 4.2.7, and in section 4.4.2.

For assignment plan entries the transmitter characteristics are given, whereas allotment plan entries are characterized by so-called Reference Networks. Reference networks are dealt with in section A4.1.3.

The detailed data needed for the characteristics of assignment and allotment plan entries can be found in GE06 Final Acts, Annex 1 [4.10].

A4.1.2 Example of reference planning configurations (for DVB-T)

A DTTB network is planned for different main reception modes. Consequently, the planning configurations (RPCs) can be grouped according to reception mode and frequency band.

The reception modes have been grouped as follows:

- fixed reception;
- portable outdoor reception, mobile reception and lower coverage quality portable indoor reception;
- higher coverage-quality portable indoor reception.

The minimum wanted field strength appropriate for fixed rooftop antenna reception is not appropriate for mobile and handheld portable reception due to the difference in their receiving antenna heights. Consequently, broadcasting networks dedicated to fixed rooftop, portable, mobile or handheld portable need different architectures.

For reference frequencies:

- 200 MHz (VHF);
- 650 MHz (UHF).

The reference planning configurations for DVB-T are summarized in Table A4.1.1.

¹⁵ The GE06 conference agreed to only consider DVB-T within its planning area, so the Reference Planning Configurations and Reference Networks given here were designed with DVB-T in mind. Very similar concepts could be used for other DTTB systems with only minor modifications.

TABLE A4.1.1
Reference Planning Configurations for DVB-T

RPC	RPC 1	RPC 2	RPC 3
Reference location probability	95%	95%	95%
Reference C/N (dB)	21	19	17
Reference $(E_{med})_{ref}$ (dB(μ V/m)) at $f_r = 200$ MHz	50	67	76
Reference $(E_{med})_{ref}$ (dB(μ V/m)) at $f_r = 650$ MHz	56	78	88

$(E_{med})_{ref}$: Reference value for minimum median field strength

RPC 1: RPC for fixed reception

RPC 2: RPC for portable outdoor reception or lower coverage quality portable indoor reception or mobile reception

RPC 3: RPC for higher coverage quality for portable indoor reception

For other frequencies, the reference field-strength values in Table A4.1.1 can be adjusted by adding the correction factor defined according to the following rule:

- $(E_{med})_{ref}(f) = (E_{med})_{ref}(f_r) + \text{Corr}$;
- for fixed reception, $\text{Corr} = 20 \log_{10}(f/f_r)$, where f is the actual frequency and f_r the reference frequency of the relevant band quoted in Table A4.1.1;
- for portable reception and mobile reception, $\text{Corr} = 30 \log_{10}(f/f_r)$ where f is the actual frequency and f_r the reference frequency of the relevant band quoted in Table A4.1.1.

The reference parameters of the RPC that are given in Table A4.1.1 (location probability, C/N , minimum median field strength) are not associated with a particular DVB-T system variant or a real DVB-T network implementation; rather, they stand for a large number of different real implementations. For instance, a DVB-T service for mobile reception might use as real implementation parameters a location probability of 99% and a rugged DVB-T variant with a C/N of 14 dB. Nevertheless, this service will be represented by RPC 2 with a reference location probability of 95% and a reference C/N of 19 dB without restricting the possibilities for the implementation of the “real” service for mobile DVB-T reception.

NOTE – For fixed roof top and portable (indoor or outdoor) reception modes of DTT, it is typical to set the target reception availability, or location probability, to 95%. This level is considered high enough (compared to the 50% target level used historically for Analogue TV planning) to provide sufficient margin above the minimum required level of field strength so that a large majority (precisely 95%) of the locations in the small reception area used for planning (see section 4.5.7.2.3) receive a level exceeding the minimum. This higher target in Digital TV compared to Analogue TV is due to the cliff-edge effect of the digital signal quality when it decreases down to the minimum level, while Analogue TV experiences progressive degradation and would still provide intelligible picture and sound even with received levels below the minimum.

The remaining 5% locations would receive a DTT field strength level below the minimum and in principle would not have any reception (cliff-edge effect). However, reception in these locations can be restored by operating some adjustments in the receiving installations. This includes for example moving slightly the receiving antenna to get a local peak of field strength or installing higher gain antenna. This is possible only when reception is fixed (roof top) or portable (stationary) indoor or outdoor.

For mobile reception, having in mind that the reception needs to be ensured in almost all the locations where the receiver can move, it is not possible to operate the above-mentioned adjustments on the move. Therefore it is sensible to set initial higher target figure for the location probability. Typically, a level of 99% for the location probability is set as target in DTT network planning for mobile reception.

The standard deviation used for the calculation of the location correction factor of each RPC are as follows:

- for RPC 1 and RPC 2: 5.5 dB in VHF and UHF,
- for RPC 3: 6.3 dB in VHF and 7.8 dB in UHF.

A4.1.3 Example of reference networks (for DVB-T)

A4.1.3.1 General considerations

Four reference networks (RNs) have been designed in order to cover the different implementation requirements for DVB-T networks.

For the determination of the power budget of the reference networks, antenna heights and powers are adjusted in such a way that the desired coverage probability is achieved at each location of the service area.

The method of adjusting the power budget of the network uses a noise-limited basis, which is known to be not very frequency-efficient. To overcome this drawback, the powers of the transmitters in the reference networks are increased by a value of 3 dB. (See Table A4.1.2 to Table A4.1.5.)

For the effective antenna heights of the transmitter in the reference networks, 150 m are used as an average value.

An open network structure has been chosen for the reference networks, since it is assumed that real network implementations will normally resemble this network type. The service area is defined as a hexagon about 15% larger than the hexagon formed by the peripheral transmitters. However, in order to allow for network implementations with very low interference potentials, a reference network with a semi-closed network structure is also introduced. (See Reference Network 4 in section A4.1.3.5.)

In some cases, the interference potentials of reference networks significantly overestimate the interference potential of real network implementations, for example, where the standard geometry of a reference network differs considerably from the particular shape of the real service area. In these cases, administrations may adopt an appropriate method, agreed on bilateral basis, to better model the interference potential of the reference network.

A4.1.3.2 Reference network 1 (large service-area SFN)

The network consists of seven transmitters situated at the centre and at the vertices of a hexagonal lattice. An open network type has been chosen, i.e. the transmitters have non-directional antenna patterns and the service area is assumed to exceed the transmitter hexagon by about 15%. The geometry of the network is given in Figure A4.1.1.

This reference network (RN 1) is applied to different cases: fixed (RPC 1), outdoor/mobile (RPC 2) and indoor (RPC 3) reception, for both Band III and Bands IV/V.

RN 1 is intended for large service area SFN coverage. It is assumed that main transmitter sites with an appropriate effective antenna height are used as a backbone for this type of network. For portable and mobile reception, the size of the real service areas for this type of SFN coverage is restricted to 150 to 200 km in diameter because of self-interference degradation, unless very rugged DVB-T system variants are used or the concept of dense networks is employed.

FIGURE A4.1.1
RN 1 (large service area SFN)

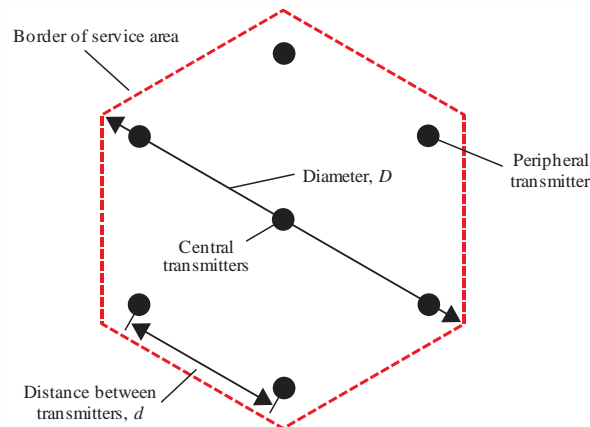

DTTB-04-01-01

TABLE A4.1.2
Parameters of RN 1 (large service area SFN)

RPC and reception type		RPC 1 Fixed antenna	RPC 2 Portable outdoor and mobile	RPC 3 Portable indoor
Type of network		Open	Open	Open
Geometry of service area		Hexagon	Hexagon	Hexagon
Number of transmitters		7	7	7
Geometry of transmitter lattice		Hexagon	Hexagon	Hexagon
Distance between transmitters d (km)		70	50	40
Service area diameter D (km)		161	115	92
Tx effective antenna height (m)		150	150	150
Tx antenna pattern		Non-directional	Non-directional	Non-directional
e.r.p. (dBW)	Band III	34.1	36.2	40.0
	Bands IV/V	42.8	49.7	52.4

NOTE – The e.r.p. is given for 200 MHz in Band III and 650 MHz in Bands IV/V; for other frequencies (f in MHz) the frequency correction factor to be added is: $20 \log_{10}(f/200)$ or $f/650$ for RPC 1 and $30 \log_{10}(f/200)$ or $f/650$ for RPC 2 and RPC 3. The e.r.p. values indicated in this table incorporate an additional power margin of 3 dB.

For the guard interval length, the maximum value $1/4 T_u$ of the 8k FFT mode is assumed. The distance between transmitters in an SFN should not significantly exceed the distance equivalent to the guard interval duration. In this case, the guard interval duration is 224 μ s, which corresponds to a distance of 67 km. The distance between transmitters for RPC 1 is taken as 70 km. For RPC 2 and RPC 3, 70 km is too large a distance from a power budget point of view. Therefore, smaller values for the distance between transmitters have been selected, 50 km for RPC 2 and 40 km for RPC 3.

A4.1.3.3 Reference Network 2 (small service area SFN, dense SFN)

The network consists of three transmitters situated at the vertices of an equilateral triangle. An open network type has been chosen, i.e. the transmitters have non-directional antenna patterns. The service area is assumed to be hexagonal, as indicated in Figure A4.1.2.

This reference network (RN 2) is applied to different cases: fixed (RPC 1), outdoor/mobile (RPC 2) and indoor (RPC 3) reception, for both Band III and Bands IV/V.

RN 2 is intended for small service area SFN coverage. Transmitter sites with appropriate effective antenna heights are assumed to be available for this type of network and self-interference restrictions are expected to be small. Typical service area diameters may be from 30 to 50 km.

It is also possible to cover large service areas with this kind of dense SFN. However, a very large number of transmitters is then necessary. It therefore seems reasonable to have large service areas being represented by RN 1, even if a dense network structure is envisaged.

FIGURE A4.1.2
RN 2 (small service area SFN)

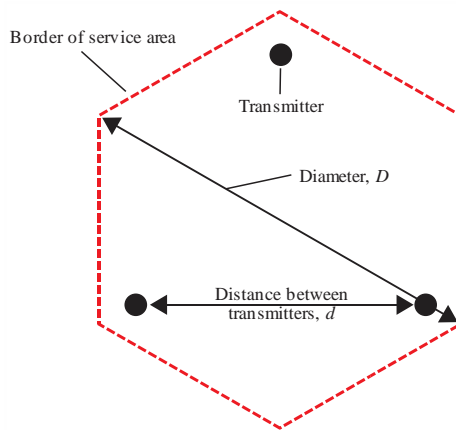

DTTB-04-01-02

In RN 2 the inter-transmitter distance is 25 km in the case of RPCs 2 and 3. It is therefore possible to use a value of $1/8 T_u$ (8k FFT) for the guard interval, which would increase the available data capacity as compared to the use of a guard interval of $1/4 T_u$. The same guard interval value might also be feasible for RPC 1, with its greater distance between transmitters of 40 km, since fixed roof-level reception is less sensitive to self-interference because of the directional properties of the receiving antenna.

The parameters and the power budgets of the RN 2 are given in Table A4.1.3.

TABLE A4.1.3

Parameters of RN 2 (small service area SFN)

RPC and reception type	RPC 1 Fixed antenna	RPC 2 Portable outdoor and mobile	RPC 3 Portable indoor
Type of network	Open	Open	Open
Geometry of service area	Hexagon	Hexagon	Hexagon
Number of transmitters	3	3	3
Geometry of transmitter lattice	Triangle	Triangle	Triangle
Distance between transmitters d (km)	40	25	25

TABLE A4.1.3 (end)

RPC and reception type		RPC 1 Fixed antenna	RPC 2 Portable outdoor and mobile	RPC 3 Portable indoor
Service area diameter D (km)		53	33	33
Tx effective antenna height (m)		150	150	150
Tx antenna pattern		Non-directional	Non-directional	Non-directional
e.r.p. (dBW)	Band III	24.1	26.6	34.1
	Bands IV/V	31.8	39.0	46.3

NOTE – The e.r.p. is given for 200 MHz in Band III and 650 MHz in Bands IV/V; for other frequencies (f in MHz) the frequency correction factor to be added is: $20 \log_{10}(f/200$ or $f/650)$ for RPC 1 and $30 \log_{10}(f/200$ or $f/650)$ for RPC 2 and RPC 3. The e.r.p. values indicated in this table incorporate an additional power margin of 3 dB.

A4.1.3.4 Reference Network 3 (small service area SFN for urban environment)

The geometry of the transmitter lattice of reference network 3 (RN 3) and the service area are identical to those of RN 2. (See Figure A4.1.2.)

RN 3 is applied to different cases: fixed (RPC 1), outdoor/mobile (RPC 2) and indoor (RPC 3) reception, for both Band III and Bands IV/V.

RN 3 is intended for small service area SFN coverage in an urban environment. It is identical to RN 2, apart from the fact that urban-type height loss figures are used. This increases the required power of the SFN transmitters by about 5 dB for RPC 2 and RPC 3.

The parameters and the power budgets of the RN 3 are given in Table A4.1.4.

TABLE A4.1.4

Parameters of RN 3 (small service area SFN for urban environment)

RPC and reception type		RPC 1 Fixed antenna	RPC 2 Portable outdoor and mobile	RPC 3 Portable indoor
Type of network		Open	Open	Open
Geometry of service area		Hexagon	Hexagon	hexagon
Number of transmitters		3	3	3
Geometry of transmitter lattice		Triangle	Triangle	Triangle
Distance d (km)		40	25	25
Service area diameter D (km)		53	33	33
Tx effective antenna height (m)		150	150	150
Tx antenna pattern		Non-directional	Non-directional	Non-directional
e.r.p. (dBW)	Band III	24.1	32.5	40.1
	Bands IV/V	31.8	44.9	52.2

NOTE – The e.r.p. is given for 200 MHz in Band III and 650 MHz in Bands IV/V; for other frequencies (f in MHz) the frequency correction factor to be added is: $20 \log_{10}(f/200$ or $f/650)$ for RPC 1 and $30 \log_{10}(f/200$ or $f/650)$ for RPC 2 and RPC 3. The e.r.p. values indicated in this table incorporate an additional power margin of 3 dB.

A4.1.3.5 Reference Network 4 (semi-closed small service area SFN)

This reference network (RN 4) is intended for cases in which increased implementation efforts regarding transmitter locations and antenna patterns are undertaken in order to reduce the outgoing interference of the network.

The geometry for RN 4 is identical to that for RN 2, except for the antenna patterns of the transmitters, which have a reduction of the outgoing field strength of 6 dB over 240° (i.e. it is a semi-closed RN). The service area of this RN is shown in Figure A4.1.3. A sharp transition from 0 dB to 6 dB reduction is assumed at the indicated bearings.

RN 4 is applied to different cases: fixed (RPC 1), outdoor/mobile (RPC 2) and indoor (RPC 3) reception, for both Band III and Bands IV/V.

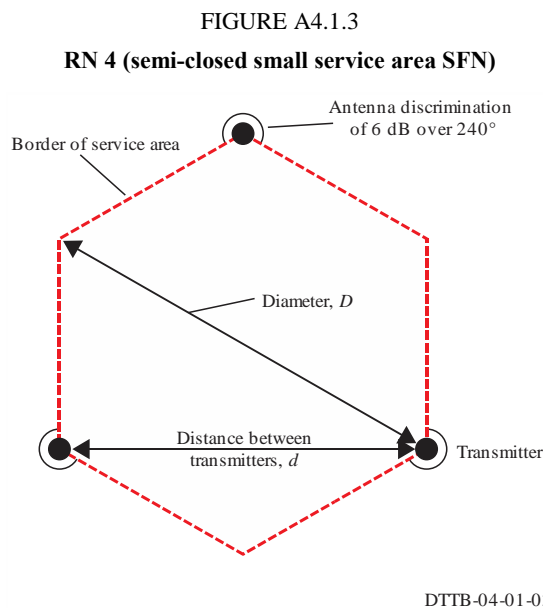

TABLE A4.1.5

Parameters of RN 4 (semi-closed small service area SFN)

RPC	RPC 1	RPC 2	RPC 3
Type of network and reception type	Semi-closed Fixed antenna	Semi-closed Portable outdoor and mobile	Semi-closed Portable indoor
Geometry of service area	Hexagon	Hexagon	Hexagon
Number of transmitters	3	3	3
Geometry of transmitter lattice	Triangle	Triangle	Triangle
Distance between transmitters d (km)	40	25	25
Service area diameter D (km)	46	29	29
Tx effective antenna height (m)	150	150	150

TABLE A4.1.5 (end)

RPC		RPC 1	RPC 2	RPC 3
Tx antenna pattern		Directional 6 dB reduction over 240°	Directional 6 dB reduction over 240°	Directional 6 dB reduction over 240°
e.r.p. (dBW)	Band III	22.0	24.0	32.5
	Bands IV/V	29.4	37.2	44.8

NOTE – The e.r.p. is given for 200 MHz in Band III and 650 MHz in Bands IV/V; for other frequencies (f in MHz) the frequency correction factor to be added is: $20 \log_{10} (f/200 \text{ or } f/650)$ for RPC 1 and $30 \log_{10} (f/200 \text{ or } f/650)$ for RPC 2 and RPC 3. The e.r.p. values indicated in this table incorporate an additional power margin of 3 dB.

The difference between RN 4 and RN 2 is the outgoing interference (interference potential). RN 4 has a lower interference potential as compared to that of RN 2. Because of this, the distance at which the same frequency can be reused is smaller when two allotments are both planned with RN 4.

There is a trade-off between this lower interference potential and the increased implementation costs to achieve the directional antennas. This should be kept in mind when choosing this RN for planning. There is also a reduction in the diameters of the service areas compared to those for RN 2.

The parameters and the power budgets of the RN 4 are given in Table A4.1.5.

Annex 2 to Chapter 4

Example Implementation Scenarios

There is no a unique way of implementing a DTTB network and basically the choice of system parameters depends on the network requirements. This annex contains examples of different implementation scenarios for DVB-T2, ISDB, DTMB and ATSC systems.

A4.2.1 DVB-T2 implementation scenarios

DVB-T2 offers a significantly wide choice of parameters and it is not possible to consider all of their possible combinations. This section considers a number of common applications of DVB-T2 and discusses some possible parameter sets which may be suitable for each of the scenarios (for more information, see Report ITU-R BT.2254 [4.43]).

Figure A4.2.1 highlights some of the parameters that may be set in DVB-T2 and summarises the impact of such choices on the DVB-T2 network.

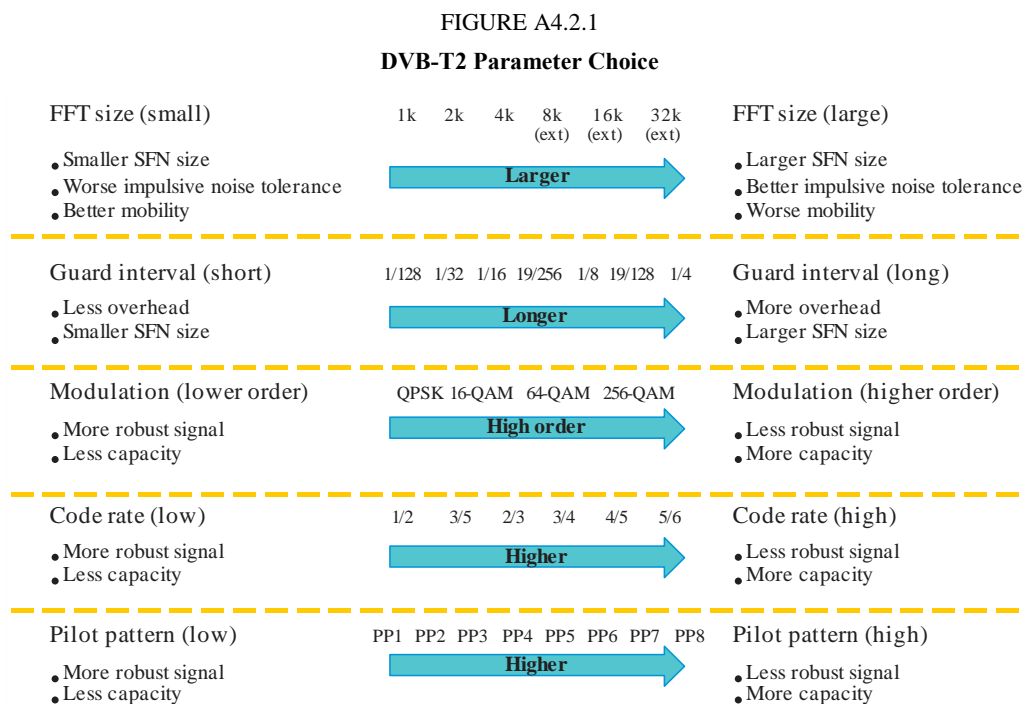

DTTB-04-01-03

Firstly, a number of scenarios appropriate to fixed roof-level reception are described. They comprise an MFN as well as an SFN approach.

Secondly, five scenarios particularly suited to portable and mobile DTT reception are described. All five scenarios are based on an SFN approach and include relatively large guard intervals to minimize intra-SFN interference and to allow greater transmitter separation. The 32k FFT mode is not applied for the same reason, since it is expected that this mode is particularly vulnerable to Doppler degradation and may be unsuitable for mobile and portable networks.

Parameters are based on the information given in the ETSI specification and Implementation Guideline – TS 102 831 [4.47], EN 302 755 [4.48]. C/N figures and respective data rates are derived according to the methodology described Report ITU-R BT.2254 [4.43] (paragraph 2.5 and Annex 2).

In scenarios 1 and 4 the parameters of a corresponding DVB-T mode are also given for comparison. The C/N values for DVB-T are taken from the respective ETSI specification, EN 300 744 [4.49], including an implementation margin of 3 dB.

A4.2.1.1 Scenario 1: MFN rooftop reception and a transition case

This scenario may be suitable for a country that wishes to implement a high-capacity network suitable for rooftop reception. It also covers the case where a country wishes to move from an established DVB-T network to one using DVB-T2. This scenario provides an example of how that transition might take place while incorporating some common practical considerations.

Of course, in the latter case, end-users would have to acquire a new set top box or TV set which is capable of demodulating DVB-T2 signals as DVB-T2 is not backward compatible to DVB-T. Consequently, a sufficiently long period of simulcasting the TV programmes in DVB-T and DVB-T2 may be advisable. More information on the transition from DVB-T to DVB-T2 can be found in the Report ITU-R BT.2254 [4.43], Chapter 6, where, inter alia, DVB-T2 variants are listed which are directly compatible with GE06 [4.10].

Although DVB-T2 may make it possible to improve or optimize the coverage of an existing network, in many cases the existing network's coverage would be considered sufficient and it would therefore be desirable to keep the coverage constant while increasing its capacity as that would allow new services to be introduced. In such situations, it would be desirable to reuse the existing infrastructure such as the transmission stations, transmitters, combiners and antenna systems. The example below would allow this type of transition with a minimum of changes – essentially the only requirement being the upgrade of modulators. The transmission side of the network, otherwise unchanged, would maintain essentially constant coverage¹⁶.

For comparison, two sets of parameters are provided, one for the DVB-T network and another for the DVB-T2. Importantly, both sets of parameters result in a similar C/N , meaning that if the transmit antennas and powers of the DVB-T network are maintained for DVB-T2, the network's coverage would essentially remain unchanged. Both sets of parameters also exhibit the same guard interval duration despite the guard interval fraction being substantially reduced for the DVB-T2 case. Again, if the transmit antennas and radiated powers remained constant in both networks, the SFN timings of the DVB-T network would translate directly to the DVB-T2 network with little change in coverage.

TABLE A4.2.1

MFN rooftop reception and a transition case

	DVB-T	DVB-T2
Bandwidth:	8 MHz	8 MHz
FFT size:	2k	32k
Carrier mode:	N/A	extended
Scattered pilot pattern:	N/A	PP7
Guard interval:	1/32 (7 μ s)	1/128 (28 μ s)
Modulation:	64-QAM	256-QAM
Code rate:	2/3	2/3
C/N (Rice):	20.1 dB	19.7 dB
Resulting data rate:	24.1 Mbit/s	40.2 Mbit/s

¹⁶ Changes to the distribution network and other similar details have not been considered.

A4.2.1.2 Scenario 2: SFN rooftop reception, maximum coverage

This scenario is intended to maximize coverage in an SFN while providing rooftop reception. In this case, it is necessary to use a relatively robust DVB-T2 mode. Several possible lengths of the guard interval may be possible depending on the network structure to be used, transmitter distance, radiated powers and terrain. Because of the relatively high robustness of the mode, it may be possible to reduce the guard interval to 1/16 (224 μ s) for very large SFNs – a change that would increase capacity.

TABLE A4.2.2

DVB-T2 SFN rooftop reception, maximum coverage

Bandwidth:	8 MHz
FFT size:	32k
Carrier mode:	extended
Scattered pilot pattern:	PP2
Guard interval:	1/8 (448 μ s)
Modulation:	16-QAM
Code rate:	2/3
C/N (Rice):	11.6 dB
Resulting data rate:	16.7 Mbit/s

A4.2.1.3 Scenario 3: SFN rooftop reception, moderate coverage

Generally, two different choices of DVB-T2 parameter sets can be identified:

- Where DVB-T2 is to replace an existing DVB-T SFN serving a moderately sized area, say up to a diameter of 100 km. This also seems to be a typically sized allotment area in the GE06 plan.
- Where there is a need to create a large area DVB-T2 SFN of “unlimited” size. In this case, it would have been difficult to use DVB-T because of SFN self-interference.

Due to limited results from DVB-T2 field trials, it may be too early to make a clear choice of code rate for the SFN case. There are two main candidates; code rates 3/5 and 2/3. The scenarios presented here are based upon the use of the 2/3 code rate, which gives higher capacity.

In these scenarios it is suggested that the 32k FFT size be used. It should be pointed out that 32k is mainly aimed at fixed rooftop reception due to its sensitivity to Doppler. It remains to be confirmed that the 32k modes are also suitable for portable indoor reception. This means that in cases where it is necessary to provide both rooftop *and* indoor reception the 16k modes may be more appropriate. This would result in the use of a higher GI fraction, and hence reduced capacity, to achieve the required guard interval duration.

A4.2.1.4 Scenario 3a: Rooftop reception for limited area SFN

The selection of the guard interval in this scenario would be the same as the longest existing DVB-T mode (224 μ s), using 8k FFT. However in this case DVB-T2 will allow use of a lower GI fraction (1/16) in order to maximize the capacity, due to the availability of 32k FFT. The use of the “new” GI fraction 19/256 (266 μ s) could also be an option in some cases in order to improve the situation where there is SFN self-interference when using 1/16.

It should be pointed out that for the rooftop reception case, SFN self-interference effects may not be as large as in the mobile or portable cases where omnidirectional receiving antennas are used. This can possibly allow for a further reduction of the GI fraction to, for example, 1/32 (112 μ s) in some cases.

For large area SFNs it is in principle also possible to use the 19/128 (532 μ s) GI fraction but preliminary results show that a GI of 448 μ s is sufficient in order to avoid self-interference in “infinitely” large SFNs.

TABLE A4.2.3

DVB-T2 Rooftop reception for limited SFN

Bandwidth:	8 MHz
FFT size:	32k
Carrier mode:	extended
Scattered pilot pattern:	PP4
Guard interval:	1/16 (224 μ s)
Modulation:	256-QAM
Code rate:	2/3
C/N (Rice):	20.5 dB
Resulting data rate:	37.0 Mbit/s

A4.2.1.5 Scenario 3b: Rooftop reception for large area SFNs

This parameter set would be used in cases where it is possible to create a large area SFN, for “nationwide coverage”. The GI fraction needs to be higher compared to the previous case in order to avoid SFN self-interference.

TABLE A4.2.4

DVB-T2 Rooftop reception for large SFN

Bandwidth:	8 MHz
FFT size:	32k
Carrier mode:	extended
Scattered pilot pattern:	PP2
Guard interval:	1/8 (448 μ s)
Modulation:	256-QAM
Code rate:	2/3
C/N (Rice):	21.2 dB
Resulting data rate:	33.4 Mbit/s

A4.2.1.6 Scenario 4: Portable reception (maximum data rate)

Scenario 4 describes a parameter set for portable reception. The parameters are adapted to the present DTT implementations based on DVB-T in Germany. They are designed for portable reception and are based on an SFN approach. The 16k mode is chosen with a guard interval length of 224 μ s. This allows for SFNs with a diameter of up to about 150 km.

TABLE A4.2.5

DVB-T2 Portable reception (maximum data rate) – FFT mode 16k

	DVB-T	DVB-T2
Bandwidth:	8 MHz	8 MHz
FFT mode:	8k	16k
Carrier mode:	N/A	extended
Scattered pilot pattern:	N/A	PP3
Guard interval:	1/4 (224 μ s)	1/8 (224 μ s)
Modulation:	16-QAM	64-QAM
Code rate:	2/3	2/3
C/N (Rayleigh):	17.2 dB	17.8 dB
Resulting data rate:	13.3 Mbit/s	26.2 Mbit/s

Since the corresponding DVB-T implementation (8k, 16-QAM-2/3, GI 1/4) allows for a data rate of 13.3 Mbit/s, this DVB-T2 scenario roughly provides twice the data rate.

If it turns out that even the 32k mode were appropriate for portable reception, the following parameter set would be possible:

TABLE A4.2.6

DVB-T2 Portable reception (maximum data rate) – FFT mode 32k

Bandwidth:	8 MHz
FFT mode:	32k
Carrier mode:	extended
Scattered pilot pattern:	PP4
Guard interval:	1/16 (224 μ s)
Modulation:	64-QAM
Code rate:	2/3
C/N (Rayleigh):	17.8 dB
Resulting data rate:	27.7 Mbit/s

However, the viability of the 32k mode for portable reception is still to be proven in field trials, whereas it is now apparent from field trials that this mode is not appropriate for mobile reception.

A4.2.1.7 Scenario 5: Portable reception (maximum coverage area extension)

On the other hand, DVB-T2 may be used to extend an existing (DVB-T) coverage while keeping the (DVB-T) data rate. This can be achieved by applying a more rugged DVB-T2 system variant. An example scenario may be:

TABLE A4.2.7

DVB-T2 Portable reception (maximum coverage)

Bandwidth:	8 MHz
FFT mode:	16k
Carrier mode:	extended
Scattered pilot pattern:	PP3
Guard interval:	1/8 (224 μ s)
Modulation:	16-QAM
Code rate:	1/2
C/N (Rayleigh):	9.6 dB
Resulting data rate:	13.1 Mbit/s

As compared to the corresponding DVB-T implementation, a gain of about 7-8 dB is achieved. This may suffice to supply large parts of an area with portable reception where previously only fixed reception was possible, or to supply portable indoor reception where previously only portable outdoor reception was possible.

A4.2.1.8 Scenario 6: Portable reception (optimal spectrum usage)

This scenario aims at an optimal spectrum usage in the sense that DTTB service areas with the same MUX content are covered by one (possibly very large) SFN. For this purpose, a very large guard interval has to be chosen. This approach is best suited for national service areas; however, it has to be kept in mind that the present GE06 plan [4.10] does not provide such large allotment areas. Thus, additional coordination is necessary to realize this scenario.

TABLE A4.2.8

DVB-T2 Portable reception (optimal spectrum usage)

Bandwidth:	8 MHz
FFT mode:	16k
Carrier mode:	extended
Scattered pilot pattern:	PP1
Guard interval:	1/4 (448 μ s)
Modulation:	64-QAM
Code rate:	2/3
C/N (Rayleigh):	18.2 dB
Resulting data rate:	22.6 Mbit/s

As compared to scenario 4, the higher expected spectrum efficiency is paid for by a smaller data rate of about 22.6 Mbit/s.

A4.2.1.9 Scenario 7: Mobile reception (1.7 MHz bandwidth in Band III)

DVB-T2 additionally provides an operation mode with 1.7 MHz bandwidth. This allows for an implementation compliant with the DAB frequency block structure of the GE06 Plan. In this way also audio and mobile TV (with low bit rate) services may be supported.

In the presented scenario, a 4k mode is chosen which allows for a relatively high data rate. However, as already encountered in a previous scenario, the viability of an FFT mode with such a small carrier separation is still to be proven in field trials.

TABLE A4.2.9

DVB-T2 Mobile reception – PP2

Bandwidth:	1.7 MHz
FFT mode:	4k
Carrier mode:	normal
Scattered pilot pattern:	PP2
Guard interval:	1/8 (278 μ s)
Modulation:	16-QAM
Code rate:	1/2
C/N (Rayleigh):	10.0 dB
Resulting data rate:	2.5 Mbit/s

A similar guard interval length to that of T-DAB is chosen in this scenario. Nonetheless, it can be expected that the SFN performance is worse for DVB-T2 since the degradation characteristics of DVB-T2 are more critical than those of T-DAB. Therefore, it might be necessary to choose a larger guard interval for the DVB-T2 scenario in order to allow for large SFN areas. A possible scenario for this could be:

TABLE A4.2.10

DVB-T2 Mobile reception – PP1

Bandwidth:	1.7 MHz
FFT mode:	4k
Carrier mode:	normal
Scattered pilot pattern:	PP1
Guard interval:	1/4 (555 μ s)
Modulation:	16-QAM
Code rate:	1/2
C/N (Rayleigh):	10.0 dB
Resulting data rate:	2.2 Mbit/s

In the end, simulations and field trials are required to assess the appropriate guard interval for this scenario.

A4.2.1.10 Scenario 8: Portable and mobile reception (common MUX usage by different services) – Multiple PLPs

This scenario describes a joint usage of a DVB-T2 multiplex by different services (high/low data rate, rugged/less rugged, etc.). A typical example could be audio/mobile TV on one hand and SD/HDTV on the other hand. This is possible in DVB-T2 because of its high flexibility with regard to the separate choice of modulation, code rate or time interleaving for each service. Restrictions have to be observed regarding the choice of the FFT mode and the scattered pilot pattern. These are common to all services and have therefore to be chosen appropriately.

TABLE A4.2.11

DVB-T2 Portable and mobile reception – multiple PLP

Bandwidth:	8 MHz
FFT mode:	8k
Carrier mode:	Extended
Scattered pilot pattern:	PP1
Guard interval:	1/4 (224 μ s)
High data rate service (TV)	
Modulation:	64-QAM
Code rate:	2/3
C/N (Rayleigh):	18.2 dB
Maximum data rate:	22.4 Mbit/s (100% high data rate, 0% low data rate service)
Low data rate service (Audio/Mobile TV)	
Modulation:	16-QAM
Code rate:	1/2
C/N (Rayleigh):	10.0 dB
Maximum data rate:	11.2 Mbit/s (0% high data rate, 100% low data rate service)

A possible partitioning of the MUX could be:

- 1.5 Mbit/s for the low data rate service (13% of the MUX capacity)
- 19.4 Mbit/s for the high data rate service (87% of the MUX capacity)

The DVB-T2-Lite profile represents a particular realization of the concept of common MUX usage by different services. This is described in more detail in Annex 5 of Report ITU-R BT.2254 “Frequency and network planning aspects of DVB-T2” [4.43].

A4.2.2 ISDB-T implementation scenarios

ISDB-T adopts OFDM (Orthogonal Frequency Division Multiplex) transmission technology, which offers robustness against multi-path interferences. Planning criteria including required C/N and protection ratio for each parameter is described in Recommendation ITU-R BT.1368 [4.30]. For constructing SFN (Single frequency Network), Report ITU-R BT.2294 [4.44] gives a guideline.

One of the features of ISDB-T is segmented OFDM transmission system, which enables fixed reception and mobile reception in the same channel. Table A4.2.12 gives an example of transmission parameter that offers both fixed and portable services in a single channel.

An example of ISDB-T parameter for portable and fixed service in same 6 MHz channel.

TABLE A4.2.12

ISDB-T portable and fixed reception

	Layer A	Layer B
Reception type:	Mobile reception	Fixed reception
Number of segment:	1	12
FFT mode:	8k	
Guard interval:	1/8	
Modulation:	QPSK	64-QAM
Code rate:	2/3	3/4
Data rate:	416 kbit/s	16.85 Mbit/s
Contents:	LDTV + data	HDTV + data

A4.2.3 DTMB implementation scenarios

DTMB offers wide range of parameters depends on the FEC constellation, Guard interval, time interleaving, pilots, PN phases rotate, and there are totally 330 modes in DTMB. It is not possible to consider all the possible combinations. This section considers a number of common applications of DTMB and highlights some possible parameter sets that may be suitable for each of the scenarios.

Firstly, a number of scenarios appropriate for fixed rooftop reception are described. They comprise an MFN as well as an SFN approach. These scenarios vary from coverage and robust requirement.

Secondly, three scenarios particularly suitable for mobile reception are described. These three modes can be used under SFN or MFN. These scenarios vary from coverage and robust requirement.

Parameters are based on the information given in the DTMB specification GB20600-2006 [4.50] and Implementation Guideline GB/T26666-2011 [4.51]. *C/N* figures and respective data rates are derived according to the methodology described ITU-R BT.1368 [4.30].

A4.2.3.1 Scenario 1: MFN rooftop reception with highest bit rate

This scenario is intended to cover a small town or city for the rooftop reception. In this case, the high robust DTMB mode may not be so critical but the bit rate is very important. It is possible to use the shortest guard interval (1/9, 56 μ s), most efficiency FEC 0.8 code rate and 64-QAM constellation. With this combination, the highest bit rate can be achieved.

TABLE A4.2.13

DTMB MFN rooftop reception (highest bit rate)

Bandwidth:	8 MHz
Sub carriers	3780
PN identification	ON
Pilots	OFF
Time interleaving	720
Guard interval:	1/9 (56 μ s)
Modulation:	64-QAM
Code rate:	0.8
<i>C/N</i> (Rice):	19.8 dB
Resulting data rate:	32.486 Mbit/s

A4.2.3.2 Scenario 2: SFN rooftop reception, maximum coverage

This scenario is intended to maximize the coverage in an SFN while supporting high robust rooftop reception. In this case, it is necessary to use a relatively robust DTMB mode. Several possible lengths of the guard interval may be considered depending on the network structure to be used, transmitter distance, radiated powers and terrain factors. In order to handle the long echo for maximum coverage, the longest guard interval 1/4 (125 μ s) will be used. In order to maintain high payload data rate, 64-QAM is selected in this scenario.

TABLE A4.2.14

DTMB SFN rooftop reception (maximum coverage 64-QAM)

Bandwidth:	8 MHz
Sub carriers	3780
PN identification	ON
Pilots	OFF
Time interleaving	720
Guard interval:	1/4 (125 μ s)
Modulation:	64-QAM
Code rate:	0.6
C/N (Rice):	16.6 dB
Resulting data rate:	21.658 Mbit/s

A4.2.3.3 Scenario 2: SFN rooftop reception, maximum coverage, high robust

This scenario is intended to maximize the coverage in an SFN while supporting very high robust rooftop reception. In this case it is necessary to use a relatively robust DTMB mode. Several possible lengths of the guard interval may be considered depending on the network structure to be used, transmitter distance, radiated powers and terrain factors. In order to handle the long echo in maximum coverage, the longest guard interval 1/4 (125 μ s) will be used. In order to achieve very high robust reception, 16-QAM is selected in this scenario.

TABLE A4.2.15

DTMB SFN rooftop reception (maximum coverage – 16-QAM)

Bandwidth:	8 MHz
Sub carriers	3780
PN identification	ON
Pilots	OFF
Time interleaving	720
Guard interval:	1/4 (125 μ s)
Modulation:	16-QAM
Code rate:	0.8
C/N (Rice):	14.3 dB
Resulting data rate:	19.251 Mbit/s

A4.2.3.4 Scenario 3: MFN rooftop reception, moderate coverage

Due to results from DTMB field trials, for moderate coverage and rooftop reception, there are two operation parameters choices. The parameters for these two modes are quite difference, from the number of subcarriers, code rate, constellation and guard interval. These two modes have similar payload bit rate.

A4.2.3.5 Scenario 3a: Rooftop reception for limited area MFN, high data rate

The selection of the guard interval in this scenario would be $1/9(55.6 \mu\text{s})$, using 3780 sub carriers and code rate 0.6, the constellation is 64-QAM.

Due to the use of multicarrier, this mode is intended to be used in big city or where the channel multipath effect changes quickly depend on the time.

TABLE A4.2.16

DTMB MFN rooftop reception (64-QAM)

Bandwidth:	8 MHz
Sub carriers	3780
PN identification	ON
Pilots	OFF
Time interleaving	720
Guard interval:	$1/9 (125 \mu\text{s})$
Modulation:	64-QAM
Code rate:	0.6
C/N (Rice):	16.6 dB
Resulting data rate:	24.365 Mbit/s

A4.2.3.6 Scenario 3b: Rooftop reception for limited area MFN, high data rate

The selection of the guard interval in this scenario would be $1/6(78.7 \mu\text{s})$, using single carrier modulation and code rate 0.8, the constellation is 32-QAM.

Due to the use of single, this mode is intended to be used in wide open area or where the channel multipath effect changes slowly depend on the time.

TABLE A4.2.17

DTMB MFN rooftop reception (32-QAM)

Bandwidth:	8 MHz
Sub carriers	1
PN identification	OFF
Pilots	OFF
Time interleaving	720
Guard interval:	$1/6(78.7 \mu\text{s})$
Modulation:	32-QAM
Code rate:	0.8
C/N (Rice):	16.6 dB
Resulting data rate:	25.989 Mbit/s

A4.2.3.7 Scenario 4: MFN/SFN rooftop reception, moderate data rate, high robust

Due to results from DTMB field trials, for moderate coverage and high robust rooftop reception, there are two operation parameters choices. The parameters for these two modes are quite difference, from the sub carriers, code rate, constellation and guard interval. These two modes have similar payload bit rate.

A4.2.3.8 Scenario 4a: Rooftop reception for limited area MFN/SFN

The selection of the guard interval in this scenario would be $1/9(55.6 \mu\text{s})$, using 3780 sub carriers and code rate 0.8, the constellation is 16-QAM.

Due to the use of multicarrier, this mode is intended to be used in big city or where the channel multipath effect changes quickly depend on the time.

TABLE A4.2.18

DTMB MFN/SFN rooftop reception ($GI\ 55.6 \mu\text{s}$)

Bandwidth:	8 MHz
Sub carriers	3780
PN identification	ON
Pilots	OFF
Time interleaving	720
Guard interval:	$1/9 (125 \mu\text{s})$
Modulation:	16-QAM
Code rate:	0.8
C/N (Rice):	14.0 dB
Resulting data rate:	21.658 Mbit/s

A4.2.3.9 Scenario 4b: Rooftop reception for limited area MFN/SFN

The selection of the guard interval in this scenario would be $1/6(78.7 \mu\text{s})$, using single carrier modulation and code rate 0.8, the constellation is 16-QAM.

Due to the use of single, this mode is intended to be used in wide open area or where the channel multipath effect changes slowly depend on the time.

TABLE A4.2.19

DTMB MFN/SFN rooftop reception ($GI\ 78.7 \mu\text{s}$)

Bandwidth:	8 MHz
Sub carriers	1
PN identification	OFF
Pilots	OFF
Time interleaving	720
Guard interval:	$1/6(78.7 \mu\text{s})$
Modulation:	16-QAM
Code rate:	0.8
C/N (Rice):	13.3 dB
Resulting data rate:	20.791 Mbit/s

A4.2.3.10 Scenario 5: mobile reception (maximum coverage area)

DTMB can support mobile reception. In order to support this function in large area, long guard interval and low order constellation, robust code rate will be needed. The following parameters can be used.

TABLE A4.2.20

DTMB mobile reception (maximum coverage)

Bandwidth:	8 MHz
Sub carriers	3780
PN identification	ON
Pilots	OFF
Time interleaving	720
Guard interval:	1/4 (125 μ s)
Modulation:	16-QAM
Code rate:	0.6
C/N (Rayleigh):	11.2 dB
Resulting data rate:	14.438 Mbit/s

A4.2.3.11 Scenario 6: mobile reception (maximum coverage area, high robust)

In order to support maximum coverage and high robust mobile reception, very robust code rate will be considered. The selection of the guard interval in this scenario would be 1/4(125 μ s), using 3780 sub carriers, code rate 0.4 and the constellation is 16-QAM.

Due to the use of multicarrier, this mode is intended to be used in big city or where the channel multipath effect changes very quickly depend on the time.

TABLE A4.2.21

DTMB mobile reception (maximum coverage, high robust)

Bandwidth:	8 MHz
Sub carriers	3780
PN identification	ON
Pilots	OFF
Time interleaving	720
Guard interval:	1/4 (125 μ s)
Modulation:	16-QAM
Code rate:	0.4
C/N (Rice):	8.7 dB
Resulting data rate:	9.626 Mbit/s

A4.2.3.12 Scenario 7: mobile reception (moderate coverage area, high robust)

The selection of the guard interval in this scenario would be 1/6(78.7 μ s), using single carrier modulation and code rate 0.8, the constellation is 4-QAM. Due to the use of 4-QAM constellation, this mode can also support mobile reception.

TABLE A4.2.22

DTMB mobile reception (moderate coverage, high robust)

Bandwidth:	8 MHz
Sub carriers	1
PN identification	OFF
Pilots	OFF
Time interleaving	720
Guard interval:	1/6(78.7 μ s)
Modulation:	4-QAM
Code rate:	0.8
C/N (Rice):	6.5 dB
Resulting data rate:	10.396 Mbit/s

A4.2.4 ATSC implementation scenarios

ATSC utilizes the 8-VSB transmission technology (an 8-level single-carrier high-data-rate amplitude-modulated suppressed-carrier vestigial sideband signal). The terrestrial broadcast mode supports one DTV signal in a single 6 MHz channel. The parameters for the 8-VSB terrestrial transmission mode are shown in Table A4.2.23.

TABLE A4.2.23

Parameters for the 8-VSB Terrestrial Transmission Mode

Parameter	Terrestrial Mode
Channel bandwidth	6 MHz
Guard bandwidth	11.5 percent
Symbol rate	10.76... Msymbols/s
Bits per symbol	3
Trellis FEC	2/3 rate
Reed-Solomon FEC	T = 10 (207,187)
Segment length	832 symbols
Segment sync	4 symbols per segment
Frame sync	1 per 313 segments
Analog co-channel rejection	Analog rejection filter in receiver
Pilot power contribution	0.3 dB
C/N threshold	~ 14.9 dB
Payload data rate	19.39 Mbps

The planning criteria including the required C/N and protection ratios for the ATSC system are described in Recommendation ITU-R BT.1368 [4.30]. ATSC receiving system characteristics are described in Recommendation ITU-R BT.2036 [4.35].

For digital television stations, service is evaluated using noise-limited contours determined by DTV planning factors in combination with field strength curves derived for 50% of locations and 90% of the time. Table A4.2.24 tabulates the planning factors used for ATSC reception.

TABLE A4.2.24

Planning factors for reception using the ATSC System

Parameters	Symbol	Low VHF	High VHF	UHF
Frequency (MHz)	F	47-68	174-216	470-806
Dipole factor (dBm to dB μ V/m)	K_d	-111.8	-120.8	-130.8
Dipole factor adjustment	K_a	0.0	0.0	See Note
Thermal noise (dBm)	N_t	-106.2	-106.2	-106.2
Antenna gain (dBd)	G	4	6	10
Download cable loss (dB)	L	1	2	4
Receiver noise figure (dB)	N_s	10	10	7
Required signal/noise ratio (dB)	S/N	15.19	15.19	15.19

NOTE – The adjustment, $K_a = 20 \log (615/(\text{channel mid-frequency}))$, is added to K_d to account for the higher field strengths required at high UHF frequencies and lower field strengths required at lower UHF frequencies.

The defining minimum field strength for ATSC coverage can be derived from the values in Table A4.2.24 and the following equation:

$$\text{Field Strength (dB}\mu\text{V/m)} = S/N + N_t + N_s + L - G - K_d - K_a \quad (1)$$

The defining field strengths for DTV service are shown in Table A4.2.25. They are used first to determine the area subject to calculation using the field strength curves, and subsequently to determine whether service is present at particular points within this area using the Longley-Rice terrain-dependent prediction. The area subject to calculation extends from the transmitter site to the distance at which the field strength predicted by the field strength falls to the value identified in Table A4.2.25.

TABLE A4.2.25

Field strengths defining the noise-limited service area subject to calculation for DTV stations

Channels	Frequency (MHz)	Defining Field Strength (dB μ V/m), (to be predicted for 50% of locations, 90% of time)
2 – 6	47-68	28
7 – 13	174-216	36
14 – 69	470-806	$41 - 20 \log \{615/(\text{channel mid-frequency in MHz})\}$

Bibliography to Chapter 4

- [4.1] **ETSI TR 101 200** – *Digital Video Broadcasting (DVB); A guideline for the use of DVB specifications and standards*
- [4.2] **Recommendation ITU-R BT.1306**, *Error correction, data framing, modulation and emission methods for digital terrestrial television broadcasting*
- [4.3] **Recommendation ITU-R BT.1877**, *Error-correction, data framing, modulation and emission methods for second generation of digital terrestrial television broadcasting systems*
- [4.4] **Recommendation ITU-R BT.2016**, *Error-correction, data framing, modulation and emission methods for terrestrial multimedia broadcasting for mobile reception using handheld receivers in VHF/UHF bands*
- [4.5] **Final Acts WRC-15, World Radiocommunication Conference**

- [4.6] **Final Acts WRC-07, World Radiocommunication Conference**
- [4.7] **Final Acts WRC-12, World Radiocommunication Conference**
- [4.8] **ITU Radio Regulations**, Edition 2015
- [4.9] **Recommendation ITU-R BT.417**, *Minimum field strengths for which protection may be sought in planning an analogue terrestrial television service*
- [4.10] **Geneva 2006** Final Acts of the Regional Radiocommunication Conference for planning of the digital terrestrial broadcasting service in parts of Regions 1 and 3, in the frequency bands 174-230 MHz and 470-862 MHz (RRC-GE06)
- [4.11] **Report ITU-R BT.2295**, *Digital terrestrial broadcasting systems*
- [4.12] **Stockholm 1961** – *Final acts of the European Broadcasting Conference in the VHF and UHF bands* (RRC ST61)
- [4.13] **Recommendation ITU-R P.310**, *Definitions of terms relating to propagation in non-ionized media*
- [4.14] **Report ITU-R BT.2137**, *Coverage prediction methods and planning software for digital terrestrial television broadcasting (DTTB) networks*
- [4.15] **Recommendation ITU-R P.1546**, *Method for point-to-area predictions for terrestrial services in the frequency range 30 MHz to 3 000 MHz*
- [4.16] **Recommendation ITU-R P.620**, *Propagation data required for the evaluation of coordination distances in the frequency range 100 MHz to 105 GHz*
- [4.17] **Recommendation ITU-R P.1812**, *A path-specific propagation prediction method for point-to-area terrestrial services in the VHF and UHF bands*
- [4.18] **Recommendation ITU-R P.1058**, *Digital topographic databases for propagation studies*
- [4.19] **Recommendation ITU-R P.452**, *Prediction procedure for the evaluation of interference between stations on the surface of the Earth at frequencies above about 0.1 GHz*
- [4.20] **Recommendation ITU-R P.526**, *Propagation by diffraction*
- [4.21] **Recommendation ITU-R P.1406**, *Propagation effects relating to terrestrial land mobile and broadcasting services in the VHF and UHF bands*
- [4.22] **Recommendation ITU-R P.833**, *Attenuation in vegetation*
- [4.23] **Recommendation ITU-R P.1238**, *Propagation data and prediction methods for the planning of indoor radiocommunication systems and radio local area networks in the frequency range 300 MHz to 100 GHz*
- [4.24] **Recommendation ITU-R P.370**, *VHF and UHF propagation curves for the frequency range from 30 MHz to 1 000 MHz Broadcasting services* (Note: Suppressed on 22/10/01)
- [4.25] **Geneva 1989** – *Final Acts of the Regional Administrative Conference for the Planning of VHF/UHF Television Broadcasting in the African Broadcasting Area and Neighbouring Countries* (RRC-GE89)
- [4.26] **OET Bulletin No. 69** – *Federal Communications Commission Longley-Rice Methodology for Evaluating TV Coverage and Interference*
- [4.27] **Recommendation ITU-R BS.1195**, *Transmitting antenna characteristics at VHF and UHF*
- [4.28] **Recommendation ITU-R BT.419**, *Directivity and polarization discrimination of antennas in the reception of television broadcasting*
- [4.29] **Recommendation ITU-R BS.599**, *Directivity of antennas for the reception of sound broadcasting in band 8 (VHF)*
- [4.30] **Recommendation ITU-R BT.1368**, *Planning criteria, including protection ratios, for digital terrestrial television services in the VHF/UHF bands*

- [4.31] **Recommendation ITU-R BT.2033**, *Planning criteria, including protection ratios, for second generation of digital terrestrial television broadcasting systems in the VHF/UHF bands*
- [4.32] **Recommendation ITU-R BS.1114**, *Systems for terrestrial digital sound broadcasting to vehicular, portable and fixed receivers in the frequency range 30-3 000 MHz*
- [4.33] **Recommendation ITU-R P.1057**, *Probability distributions relevant to radiowave propagation modelling*
- [4.34] **Recommendation ITU-R P.1407**, *Multipath propagation and parameterization of its characteristics*
- [4.35] **Recommendation ITU-R BT.2036**, *Characteristics of a reference receiving system for frequency planning of digital terrestrial television systems*
- [4.36] **Recommendation ITU-R BT.2052**, *Planning criteria for terrestrial multimedia broadcasting for mobile reception using handheld receivers in VHF/UHF bands*
- [4.37] **Report ITU-R BT.2382**, *Description of interference into a digital terrestrial television receiver*
- [4.38] **Report ITU-R BT.2386**, *Digital Terrestrial Broadcasting: Design and implementation of single frequency networks (SFN)*
- [4.39] **Recommendation ITU-R SM.1875**, *DVB-T coverage measurements and verification of planning criteria*
- [4.40] **EBU Technical Review OFDM Receivers – Impact on Coverage of Inter-Symbol Interference and FFT window positioning**
- [4.41] **ETSI TS 101 191 – Digital Video Broadcasting (DVB); DVB mega-frame for Single Frequency Network (SFN) synchronization**
- [4.42] **Report ITU-R BT.2140**, *Transition from analogue to digital terrestrial broadcasting*
- [4.43] **Report ITU-R BT.2254**, *Frequency and network planning aspects of DVB-T2*
- [4.44] **Report ITU-R BT.2294**, *Construction technique of DTTB relay station network for ISDB-T*
- [4.45] **Report ITU-R BT.2343**, *Collection of field trials of UHDTV over DTT networks*
- [4.46] **Report ITU-R BT.2385**, *Reducing the environmental impact of terrestrial broadcasting systems*
- [4.47] **ETSI TS 102 831 – Digital Video Broadcasting (DVB); Implementation guidelines for a second generation digital terrestrial television broadcasting system (DVB-T2)**
- [4.48] **ETSI EN 302 755 – Digital Video Broadcasting (DVB); Frame structure channel coding and modulation for a second generation digital terrestrial television broadcasting system (DVB-T2)**
- [4.49] **ETSI EN 300 744 – Digital Video Broadcasting (DVB); Framing structure, channel coding and modulation for digital terrestrial television**
- [4.50] **GB 20600-2006 – Framing structure, channel coding and modulation for digital television terrestrial broadcasting system**
- [4.51] **GB/T 26666-2011 – Implementation guidelines for transmission system of digital terrestrial television broadcasting**

CHAPTER 5

Sharing and Protection

5.1 Introduction

DTTB, in common with any radiocommunication system, is susceptible to interference from other electronic systems that, by design or otherwise, emit radio signals. Understanding and management of these interfering signals is a key part of the work of the broadcast network operators and the spectrum regulators. The reverse is also true, of course, that DTTB has the potential to cause interference to other radio systems.

Section 5.2 describes the different categories of interference.

Section 5.3 provides sources of technical characteristics and parameters required to analyse inter-system or intra-system compatibility involving DTTB.

Section 5.4 provides reference sources for criteria, methods, studies and field reports related to sharing and compatibility issues between DTTB and IMT. This section touches also upon about compatibility between DTTB and other wireless communication systems that might be introduced on a secondary basis in the UHF band in some countries e.g. “classical” broadband bi-directional WSD and possible future unidirectional WSD from 470 MHz upwards. This usage is different from narrow-band PMSE (see section 5.6).

Section 5.5 provides indications about various compatibility issues involving DTTB: impact from GSO broadcasting satellite systems, Wind Turbines, Power Line Communication (PLC) systems and Ultra-Wide-Band (UWB) systems on DTTB.

Section 5.6 provides indications about actual sharing between DTTB and SAB/SAP in the broadcasting bands.

5.2 Categories of Interference

Broadly, interference to DTTB can arise from other systems (inter system compatibility) designed to emit radio signals (e.g. mobile broadband networks) or from systems not designed to emit radio signals, but which do so anyway (e.g. power-line transmission networks). A third case involves disturbance to the DTTB signals from physical objects that lie in the signal path between transmitter and receiver (e.g. wind turbine generators).

The interference may be the result of unwanted emissions outside the necessary bandwidth of the source of interference occurring in the “out of band¹⁷” domain or the “spurious¹⁸” domain which overlap the wanted DTTB channel, or it may result from disturbances, internal to DTTB receivers, generated by overload, cross modulation or intermodulation involving strong signals from other radiocommunication systems operating in the same or adjacent frequency bands.

In the case of in-band interference (that originates from emissions in the same frequency band or channel as the wanted DTTB signal), mitigation is generally accomplished by utilizing network design elements, such as geographical spacing or antenna discrimination.

For out-of-band and spurious interference (that originates in other frequency bands or channels, typically adjacent bands), it is usual to specify acceptable out-of-band and spurious emission levels for the equipment before it comes to market.

As for unwanted emissions from equipment not designed to emit radio signals at all, it is usual to specify acceptable emission levels for the equipment before it comes to market.

In addition, improving selectivity of the DTTB receiving installation as well as geographical spacing and antenna discrimination can also be used to overcome the various interference mechanisms that can arise.

¹⁷ Within 250% of the necessary bandwidth.

¹⁸ Generally beyond the out of band domain.

Basically, the same mechanism of interference can also occur between DTTB systems (intra-system compatibility) either inside a given network or between different networks (inside or across national borders). The difference with the case of interference with systems of other radiocommunications services or applications is in the management of interference:

- Inside the national borders,
 - For the compatibility between DTTB transmission themselves, it is usually the broadcast network operators, that hold the licences for DTTB transmitting stations, who ensures the compatibility by proper design of the network. See Chapter 4 for detailed description of the broadcast network planning.
 - For the compatibility between DTTB transmissions and transmissions of other radiocommunication services or applications, it is the responsibility of the national regulator to ensure compatibility or to solve interference cases if they occur.
- Across national borders, compatibility between DTTB transmissions themselves or between DTTB transmissions and other radiocommunication services is usually ensured by the respective regulators and network operators (for broadcast and for other services) of the neighbouring countries. They coordinate the detailed frequency usage and the transmission characteristics in order to avoid cross border interference. The ITU-R Bureau is available for providing assistance in the coordination process and in solving possible interference cases. Chapter 7 provides further information on coordination procedures.

5.3 Sources for general technical characteristics and criteria for sharing

In order to conduct sharing studies, characteristics of Digital Terrestrial Television Broadcasting (DTTB) systems must be defined. Related information can be found in the following ITU-R Recommendations and Reports:

- Recommendation ITU-R BT.419 – Directivity and polarization discrimination of antennas in the reception of television broadcasting.
- Recommendation ITU-R BT.500 – Methodology for the subjective assessment of the quality of television pictures.
- Recommendation ITU-R BT.1195 – Transmitting antenna characteristics at VHF and UHF.
- Recommendation ITU-R BT.1206 – Spectrum limit masks for digital terrestrial television broadcasting.
- Recommendation ITU-R BT.1306 – Error correction, data framing, modulation and emission methods for digital terrestrial television broadcasting.
- Recommendation ITU-R BT.1877 – Error-correction, data framing, modulation and emission methods for second generation of digital terrestrial television broadcasting systems.
- Report ITU-R BT.2138 – Radiation pattern characteristics of UHF television receiving antennas.
- Report ITU-R BT.2383 – Characteristics of DTTB systems in the frequency band 470-862 MHz for frequency sharing/interference analyses.

One important parameter to insure protection from other services is the protection ratio. For the first generation of DTTB systems, relevant figures of protection ratios are presented in the following Recommendation:

- Recommendation ITU-R BT.1368 – Planning criteria, including protection ratios, for digital terrestrial television services in the VHF/UHF bands.

For second generation DTTB systems, relevant figures of protection ratios are presented in the following Recommendation:

- Recommendation ITU-R BT.2033 – Planning criteria, including protection ratios, for second generation of digital terrestrial television broadcasting systems in the VHF/UHF bands.

For Terrestrial Multimedia broadcasting for mobile reception using handheld receivers, the relevant figures of protection ratios are presented in the following Recommendation:

- Recommendation ITU-R BT.2052 – Planning criteria for terrestrial multimedia broadcasting for mobile reception using handheld receivers in VHF/UHF bands.

Non-linearity of television devices also needs to be taken into account since it can cause intermediate interference. For such effect, relevant studies are presented in the following Report:

- Report ITU-R BT.2298 – Reference model to be used for the assessment of interference into the television broadcasting service in order to take into account non-linearity in the television radiofrequency receiving system.

A description of interference mechanism in a DTTB receiver is provided in the following Report:

- Report ITU-R BT.2382 – Description of interference into a DTT receiver.

A general but important source dealing with protection criteria for terrestrial broadcasting systems is the following Recommendation:

- Recommendation ITU-R BT.1895 – Protection criteria for terrestrial broadcasting systems.

Concerning the methodology to assess the impact of interference on broadcast coverage, a conceptual method is described in the following Report:

- Report ITU-R BT.2248 – A conceptual method for the representation of loss of broadcast coverage.

5.4 Reference sources related to compatibility between DTTB and the Mobile service

For the sharing between digital terrestrial television broadcasting and mobile service, relevant studies are presented in the following Reports:

- Report ITU-R BT.2247 – Field measurement and analysis of compatibility between DTTB and IMT.
- Report ITU-R BT.2337 – Sharing and compatibility studies between digital terrestrial television broadcasting and terrestrial mobile broadband applications, including IMT, in the frequency band 470-694/698 MHz.
- Report ITU-R BT.2339 – Co-channel sharing and compatibility studies between digital terrestrial television broadcasting and international mobile telecommunication in the frequency band 694-790 MHz in the GE06 planning area.

For the assessment of interference from the mobile service to the broadcasting service, relevant studies are presented in the following Reports:

- Report ITU-R BT.2265 – Guidelines for the assessment of interference into the broadcasting service.
- Report ITU-R BT.2296 – Example of application of Recommendation ITU-R BT.1895 and Report ITU-R BT.2265 to assess interference to the broadcasting service caused by the impact of IMT systems on existing head amplifiers of collective television distribution systems.

A number of countries have recently introduced new mobile services particularly international mobile telecommunications (IMT) utilizing part of the UHF band where broadcasting service and mobile service have co-primary allocations. For the DTTB Services protection in conjunction with IMT, relevant studies are presented in the following Report:

- Report ITU-R BT.2301 – National field reports on the introduction of IMT in the bands with co-primary allocation to the broadcasting and the mobile services.

5.5 Reference sources related to other compatibility issues involving DTTB

The presence of Wind Turbines in the coverage area of a DTTB transmitter may create disturbance to the reception in some parts of this area. The following ITU-R documents provide the required description of the disturbance and the methodology to assess it:

- Report ITU-R BT.2142 – The effect of the scattering of digital television signals from a wind turbine.
- Recommendation ITU-R BT.1893 – Assessment methods of impairment caused to digital television reception by wind turbines.

The possible impact of Ultra Wide Band devices to the broadcasting service is studied in:

- Recommendation ITU-R SM.2057 – Studies related to the impact of devices using ultra-wideband technology on radiocommunication services.

The possible impact of Geostationary (GSO) and non-Geostationary (non-GSO) broadcasting-satellite to the broadcasting service¹⁹ is studied in:

- Report ITU-R BT.2075 – Protection requirements for terrestrial television broadcasting services in the 620-790 MHz band against potential interference from GSO and non-GSO broadcasting-satellite systems and networks.

Regarding the potential impact of Power Line Communication systems on DTTB, it is noted that existing PLC systems as specified in Recommendation ITU-T G.9964 – Unified high-speed wireline-based home networking transceivers – Power spectral density specification, feature a rapid power roll-off above about 80 MHz. However, PLC developments outside ITU-T continue with a firm intention to use higher and higher frequencies, particularly for in-home distribution of HD and UHD television signals. Such devices will inevitably have to operate at higher frequencies and increase radiation through, for example, the use of the mains earth wire, as well as the live and neutral wires. Deployment of such systems will become an issue also for DTTB in the VHF and UHF bands as well as for other radiocommunication systems operating in the VHF and low UHF bands.

5.6 Indications about actual sharing between DTTB and SAB/SAP

SAB/SAP systems effectively share the spectrum used by DTTB on the basis of a secondary allocation. Information about these systems can be found in the following Reports:

- Report ITU-R BT.2238 – Services ancillary to broadcasting/services ancillary to programme making spectrum use in Region 1 and the implication of a co-primary allocation for the mobile service in the frequency band 694-790 MHz.
- Report ITU-R BT.2244 – Information on technical parameters, operational characteristics and deployment scenarios of SAB/SAP as utilized in broadcasting.

A usual way of accommodating SAB/SAP in the VHF/UHF is either having a geographical database indicating the available frequencies to use or having computer software calculating the available frequencies at a given location. There may be intervention of an operator (regulator or other) to coordinate this use.

¹⁹ There is no current known use of GSO or non-GSO broadcasting-satellite systems in Bands III, IV and V.

CHAPTER 6

Cross-border coordination

6.1 Coordination procedures

Due to limited radio frequency resource and with increasing use of radio technologies, it is necessary to carry out certain frequency coordination procedures that aim to minimize the impact from one radio service on existing primary radio services which are sharing the same frequency range.

Frequency coordination is the negotiation between two or more administrations to agree on the operating conditions (frequency, effective radiated power, antenna height, radiation pattern, etc.) of its stations. The aim of this negotiation is to prevent the stations causing harmful interference when they start their service (or at least, to minimize such interference to an acceptable level).

Basically, there are two (non-exclusive) coordination procedures:

- Coordination inside the Planning Area of a Regional Agreement
- Coordination outside the Planning Area of a Regional Agreement

6.1.1 Coordination inside the Planning Area of a Regional Agreements

When a Regional Agreement exists, such as GE06 in Region 1²⁰, it is necessary to apply the procedures laid out in the Agreement to obtain international recognition and the right to protect services from harmful interference, without prejudice that other coordination procedures may also be applied in advance, such as coordination by bilateral or multilateral discussion (see section 6.1.3). In such a case, when notifying an assignment to the Master International Frequency Register (MIFR), two conformity checks are done by the Radiocommunication Bureau (BR):

- Conformity check with the Table of frequency allocation;
- Conformity check with the Regional Agreement and its associated Plan(s).

The following text is based on the specific case of the GE06 Agreement. Section 1 of Annex 4 of GE06 provides the agreed methodology for determining the coordination area. Coordination will be required with those administrations whose territory lies wholly or partly within the coordination area.

The inclusion in the Plan of a new station, or the modification of the registered parameters of a station, is carried out in accordance with the Plan modification procedure established in Article 4 of GE06.

This procedure consists of the publication of the station with its technical specifications as set out in Part A of a Special Section of the International Frequency Information Circular of the Radiocommunication Bureau (BRIFIC). The publication in Part A is considered as a formal frequency coordination consultation to other administrations. The BRIFIC includes the list of administrations with which coordination is required and, whose agreement is therefore necessary. The period within which an administration may request more information or to submit comments, conditions, or objections either directly to the notifying administration or through the BR ends in 75 days. After that period, if an administration from which agreement is required does not reply, the request is deemed to be disagreed. However, if there is a request from the notifying administration, the BR will send a reminder to the affected administration(s) and grant a further period for comment of 40 days. The absence of a reply within this new deadline implies that the consulted administration has no objections.

Once the agreement between the involved administration(s) has been reached, the notifying administration may request the publication of the station with the technical specifications agreed in Part B of a Special Section GE06 of BRIFIC. The publication in Part B marks the formal entry of the station into the GE06 Plan.

²⁰ The GE06 Agreement covers all of Region 1 except Mongolia, and also the Islamic Republic of Iran.

GE06 allows some flexibility, known as the “envelope concept”. Operational stations are not required to follow all the parameters registered in advance. However, the actual operating parameters shall not cause more interference, nor claim more protection, than that of the station(s) recorded in the Plan. For example, a registered station may start its service with a lower effective radiated power or a lower antenna height than the registered value.

It is also possible to cancel (or “suppress”) a registered station in GE06. In this case, the incumbent administration will request the publication of such station in Part C of a Special Section GE06 of BRIFIC.

6.1.2 Coordination outside the Planning area of a Regional Agreements

When there is no Regional Agreement, for the notification of an assignment to the MIFR, the BR will only check conformity of the assignment with the Table of frequency allocation. Any coordination between neighbouring countries is left to the administrations concerned, and the BR has no mandatory responsibility in this regard.

6.1.3 Bilateral or multilateral discussion

In either case above, administrations may choose to consult each other by means of bilateral or multilateral discussion. The discussion can be done by correspondence (mail, email, etc.) and/or by meeting. This can be applicable between administrations that are not party to a Regional Agreement, or administrations within a Regional Planning Agreement area when they wish to “pre-coordinate” before formal submission of their assignments to the BR, or after such submission when the need for coordination has been determined by the BR.

Discussion by correspondence is a general procedure if the administrations that may be affected within the coordination area maintain good relationships in the field of radio communications. The discussion is carried out by providing the planned technical characteristics of the station to be coordinated. In this case, the coordination query may be done either directly or through the BR. In principle, there are no deadlines within which more information may be requested or comments, conditions, or objections submitted, unless the administrations concerned agree to set such a deadline. Some administrations in Region 1, for example, apply the same deadlines as in the GE06 Agreement.

In case of discussion by correspondence, the administrations concerned may inform the BR about the agreement that has been reached between the administrations by providing written documents.

If the discussion by correspondence is unsuccessful, a coordination meeting may be held in order to progress the negotiations.

These meetings can be bilateral, with only two administrations in attendance, or multilateral when more than two administrations are involved in the coordination process.

Coordination meetings are usually held in a city in the territory of any of the administrations involved, but can also be held elsewhere, for example in Geneva, at the convenience of the administrations concerned.

The participants in these meetings are administrations or other regulatory authorities. Broadcasters, audio-visual councils, operators or other may be invited at the choice of the administrations themselves.

To allow evaluation of the compatibility situations during the meetings, it can be useful to have means of calculating compatibility to hand in the meeting. It is also advised that each administration prepares in advance the key objectives of each meeting as this will help in the progress of the meeting. Minutes of such meetings are usually prepared by one of the administrations present by agreement with the other(s), and approved by them all either at the end of the meeting or afterwards. A part of the meeting may be dedicated to reviewing the minutes before the end of the meeting (if they are prepared in time) so that they can be agreed by all parties. Alternatively, the minutes can be circulated after the meeting and agreed by correspondence, or at the subsequent meeting.

When the negotiation has concluded, the agreement reached is normally reflected in the minutes of the coordination meeting, or in a separate document agreed by all parties. The administrations concerned may agree to inform the BR of the outcome, possibly by providing a copy of the minutes of the meeting.

The advantages and disadvantages of coordination procedures are shown in Table 6.1.

TABLE 6.1
Advantages and disadvantages of coordination procedure

	By correspondence	By meeting
Advantages	Technical characteristics may be determined prior to the application of the ITU coordination procedure.	The ability to unclog unresolved cases, obtain agreements in much shorter time frames. The working relationships between administrations may be promoted.
Disadvantages	It can be extended indefinitely in time, especially when a consulted administration is not motivated to answer the request for strategic reasons or otherwise.	Preparation such as exchanging necessary documents to ensure the effectiveness of meeting is needed in advance.

It should be emphasized that materials used in this chapter is merely of informative nature and they do in no way constitute, supersede nor replace any mandatory provision/procedure already agreed or are being agreed by the ITU as contained in the relevant Regional Agreements and those Agreements concluded under Article 6 of the RR.

6.2 Coordination examples

6.2.1 Region 1

In Region 1, all countries except Mongolia and including Iran are situated in the GE06 planning area. Countries within the GE06 planning area shall refer to the coordination procedure within the GE06 Agreement [6.1]. Countries which have neighbouring countries outside the GE06 planning area should coordinate with those neighbouring countries as needed.

A few coordination and planning examples in Region 1 are shown below.

6.2.1.1 Spain and neighbouring countries

Spain is a country on the periphery of Europe, which requires coordination with both administrations of CEPT countries and non-CEPT countries, often with divergent interests.

Stations located close to land borders require coordination with Andorra, France and Portugal, while stations near the coast require coordination with Algeria and Morocco and sometimes with Ireland, Italy, Malta, Mauritania, Monaco, the UK and Tunisia.

Propagation paths, in most cases, are exclusively land paths, but in some cases are mixed land/sea paths with a percentage of cold sea (around northern Spain) or warm sea (in the Mediterranean Sea and around the Canary Islands) where super-refraction phenomena occasionally occur, particularly in the summer.

Spain is part of the GE06 Regional Agreement, as are all its neighbouring administrations. If agreed by administrations, the technical criteria used for coordination can differ from the GE06 criteria in order to adapt to the topology of the countries involved in the coordination.

Due to the diversity of administrations with which it coordinates, and the different conditions of propagation paths, Spain uses different technical criteria for coordination depending on the administration concerned. It has not always been possible, however, for Spain to reach agreements with some of its neighbouring administrations to use technical criteria different from those in GE06.

With some of the administrations, coordination has been more frequent and Spain has obtained agreement to use certain technical criteria coordination with the format shown in the following Table:

TABLE 6.2

Example of coordination criteria

Evaluation of compatibility between DTT stations	Internal criteria (Spain)	Internal criteria (neighbouring country)	Criteria for bilateral coordination
Protection area	Service area		
Estimated field strength of wanted signal	Rec. ITU-R P.526 (Fresnel-Deygout model)		
Estimated field strength of interfering signal (land path)	Rec. ITU-R P.526 (Fresnel-Deygout model)		
Estimated field strength of interfering signal (sea path)	Rec. ITU-R P.1546		
Interpolation in mixed land-sea paths (Rec. ITU-R P.1546)	Parabolic		
Consideration of terrain clearance angle (Rec. ITU-R P.1546)	Yes		
Time percentage of interference	1%		
Type of terrain* (clutter)	No		
Protection ratios	Rec. ITU-R BT.1368		
Discrimination of receive antennas	No		
Cross-polarisation discrimination	No		
Protection margin C/I	0 dB		
Receive antenna height	10 m		
Minimum field strength fixed antenna reception	55 dB μ V/m+20log[f(MHz)/650]		
Digital model of the terrain/Resolution	1:200 m/200 m \times 200 m		

* In non-populated areas and in mountain summits it will be assumed that there is no interference.

When a requirement needs to be coordinated with both neighbouring CEPT countries and with non-CEPT countries, Spain will begin by direct consultation with those administrations; and when necessary, bilateral coordination meetings will also be held. When agreement is reached, Spain applies the publication procedure in a special section of the GE06 Regional Agreement.

In the case of coordination with non-CEPT administrations only, Spain starts by applying the coordination procedure by publication in a special section of the GE06 Regional Agreement and, if necessary, a bilateral coordination meeting takes place, to continue the process of publication in the GE06 Regional Agreement (see section 6.1.1).

6.1.1.2 Sub-Saharan Africa

The African Telecommunication Union (ATU), with the assistance of the ITU, conducted an 18-month-long negotiation and coordination process between 2011 and 2013 to complete modification to the GE06 Plan in the band 470-694 MHz in order to release the frequency bands above 694 MHz (the 700 MHz and the 800 MHz bands) from broadcasting.

The main features and outcome of this re-planning and coordination process can be summarized as follows:

- 47 countries (shown in Figure 6.1) participated in the process (except Mauritius).

FIGURE 6.1
Sub-Saharan African GE06 region



DTTB-06-01

- The launch of the process took place formally through two African summits (held in Nairobi in 2011 and Accra in 2012).
- Three planning and coordination meetings took place in Bamako, Kampala and Nairobi during the process. In addition, several sub-regional groups meetings (EACO, ECOWAS, SADC, etc.) took place with the participation of ITU BR.
- The target number of coverage layers (multiplexes) per site was set to four.
- 33 iterations for the compatibility analysis were required, based on the requirements submitted by administrations. The BR generated the requirements for the absent countries following a request to do so from the ATU.
- 7107 frequency requirements in 470-694 MHz were submitted (cf. 11406 frequency requirements at the RRC-06 for the entire band 470-862 MHz).
- At the end of the process the average percentage of satisfied requirements reached 97.37%.
- The process took 18 months to complete.

More detailed information can be found on the following web sites:

- “ITU assistance to the GE06 frequency Coordination meetings in Sub-Saharan Africa (ATU) and Arab Region (ASMG)” – Ilham Ghazi, Head of broadcasting services division, Radiocommunication Bureau, ITU. Presentation at the ITU International symposium on Digital Switchover, 17 June 2015. See <http://www.itu.int/en/ITU-R/GE06-Symposium-2015/Pages/default.aspx>
- ITU Web page “GE06 Frequency coordination for sub-Saharan Africa”. See <http://www.itu.int/net/ITU-R/terrestrial/broadcast/ATU/>

6.1.1.3 Arab countries (North Africa and Middle East)

The Arab Spectrum Management Group (ASMG), assisted by the BR, started a coordination process in March 2014 with the aim of ensuring sufficient spectrum for broadcasting in the 470-694 MHz band, and to be able to free the 700 and 800 MHz bands.

The main features and outcome of this re-planning and coordination process can be summarized as follows:

- 17 countries (shown in Figure 6.2) participated in the process.

FIGURE 6.2
Arab countries GE06 region



DTTB-06-02

- The process was officially triggered by the Permanent Arab Committee for Communications and Information (Cairo, 4-5 March 2014) and contributions of the Technical Secretariat of the Council of Arab Ministers for Communications and Information.
- Three planning and coordination meetings took place in Dubai, Hammamet and Marrakech during the process.
- An objective of four layers per Administration was set, knowing that this number can be increased in the future, individually, and according to the needs of the Arab states, according to GE06 Article 4 Procedures.
- 27 iterations for the compatibility analysis were required, based on the requirements submitted by administrations. The BR generated the requirements for the absent countries following a request to do so from the ASMG.
- 4 346 frequency requirements in 470-694 MHz were submitted (cf. 9151 at the RRC-06 for the entire band 470-862 MHz).
- At the end of the process the average percentage of satisfied requirements reached 76.87%.
- The process took 11 months to complete.

More detailed information can be found in the following web sites:

- “ITU assistance to the GE06 frequency Coordination meetings in Sub-Saharan Africa (ATU) and Arab Region (ASMG)” – Ilham Ghazi, Head of broadcasting services division, Radiocommunication Bureau, ITU. Presentation at the ITU International symposium on Digital Switchover, 17 June 2015. See <http://www.itu.int/en/ITU-R/GE06-Symposium-2015/Pages/default.aspx>
- ITU Web page “Arab Spectrum Management Group (ASMG) – GE06 Frequency Coordination Meetings”. See <http://www.itu.int/en/ITU-R/terrestrial/broadcast/ASMG/Pages/default.aspx>

6.1.1.4 Western Europe

Following the finalisation of the first CEPT Digital Dividend study, a group of Administrations decided that they wanted to discuss the consequences of the implementation of the Digital Dividend from a strategic perspective. In 2009 they founded the Western European Digital Dividend Implementation Platform (WEDDIP).

This group (containing eight Administrations: Belgium, Germany, France, Ireland, Luxembourg, the Netherlands, Switzerland and the United Kingdom) conceived Terms of Reference in which they agreed to coordinate the frequency coordination activities carried out by its member countries in order to implement the digital dividend, with a view to:

- A) achieving mutual compatibility of the spectrum resources to be used in the VHF and UHF bands following the implementation of the digital dividend, for both broadcasting and/or mobile services;
- B) facilitating any consequential modifications to the GE06 Plan; and
- C) continuing to respect the principle of equitable access to spectrum resources in the spirit of GE06, while taking into account relevant future developments.

The Group committed that its members would work on the basis of consensus.

6.1.1.4.1 800 MHz situation

WEDDIP provided its members a platform to discuss the release of the 800 MHz band, facilitating the negotiation activities. It was also offering its members the possibility to share the results of these negotiations at its meetings. This was done on a voluntary basis as some members had made a decision on the release of the 800 MHz band from DTTB, while some other Administrations entered the discussion on a theoretical technical basis only.

At 11 meetings (starting September 2009) WEDDIP members discussed the consequences of the release of the 800 MHz band on the above described agreed working principles the release of the 800 MHz band. As this was the first regional attempt to discuss a complex frequency re-farming issue, members had to learn how to find solutions fitting all the required solutions. In December 2012, WEDDIP held its 11th meeting concluding that the majority of requirements were acceptable. One outstanding topic could not be solved through the WEDDIP process.

6.1.1.4.2 700 MHz situation

When WRC-2012 decided that the 700 MHz band (694-790 MHz) was allocated on a co-primary basis to the mobile service and identified for IMT, WEDDIP started the considerations on how to clear the 700 MHz band of DTT.

For some Administrations, the release of the 700 MHz band was a real issue because on a political level the decision was made to use the band for the mobile service only, other Administrations were considering to continue DTT distribution in the band.

Nevertheless, WEDDIP acknowledged the fact that a release of the 700 MHz band from DTT would only be a matter of time.

Although the WEDDIP group was working on a voluntary basis, the group decided that the process of releasing the 700 MHz band would need more formal agreements. Time pressure was one of the reasons hence some members had to release the 700 MHz on a short notice.

WEDDIP members agreed that for each country a reasonable TV distribution was guaranteed. If for example in a given country 6 multiplexes are being operated to distribute 25 programmes, in the new situation the number of multiplexes available should also be able to distribute the same amount of programs. It was acknowledged that licence conditions, as they vary by country, have to be respected. As far as feasible, the distribution infrastructures should stay the same. Although frequency or coverage areas may be different, the sites from which they are transmitting should stay the same as far as feasible. DVB-T2 will be the only planning principle as this allows members to benefit from the advantages DVB-T2 has above the DVB-T planning principle on which the GE06 frequency plan was created.

WEDDIP members also agreed on the coordination zones to be respected. Furthermore, the group agreed to use a database containing all the 700 MHz channels subject to the re-farming process and all channels in the remaining DTTB band (470-694 MHz). These channels should be identified as:

- being in use;
- being licensed (but not yet in operation);
- channels under consideration and channels not in use, nor licensed but agreed as a result of bi- or multi-lateral negotiations.

In the process of releasing the 700 MHz band, members agreed to disclose all national plans (as they exist in the coordination zone). While discussing the options, members took into account economic aspects and target objectives as they exist in a given country.

In regard to the interference approaches, usable wanted signal strength in the required coverage area, maximum field strength levels at relevant test points (e.g. at the border of a service area or at a certain distance of a country border), the defined service areas, and the *C/I* calculations method and calculations margins were agreed. The agreed values could vary per agreement reached between two or more members.

As these activities required many technical planning meetings on bi- or multi-lateral level, these meetings were also held between the main WEDDIP ‘review’ meetings.

WEDDIP was also used to agree on transition arrangements, although the responsibility for that was with the Administrations involved.

In order to finalize the creation of a new frequency plan successfully, a timeline and a roadmap was agreed. A timeline/roadmap was covering the exchange of demands/needs for DTTB in the band 470-694 MHz; the type of submitted requirements (modification, deletion or addition) and analyses of the compatibility of the submitted requirements.

The timeline also set a sequence of meetings in which members agreed to come to the finalisation of the frequency plan. Even a ‘deadline/end date’ was agreed.

The release of the 700 MHz band process ended with the signing of an agreement. This agreement summarised the agreed frequency arrangements as well as those issues for which no agreement was available at that moment.

In all, WEDDIP held 13 meetings related to 700 MHz release, between 2013 and 2016.

After the successful finalisation of the 700 MHz band release, WEDDIP is putting its activities on hold. It will call for a meeting if one of its members is requesting it.

Conclusions

WEDDIP is a group of independent countries dealing with the consequences of the Digital Dividend implementation; WEDDIP was and is facilitating the release of the 800 MHz and 700 MHz band and its consequential effect on the re-distribution of DTTB-channels below 694 MHz; although WEDDIP plays a key role in this process, the overall responsibility is and stays with its individual members; as the release of the 800 MHz band took more than three years and the release of the 700 MHz band around two years, WEDDIP sees itself as an example that (sub)regional approach of delicate issues related to frequency negotiation activities can benefit countries involved. As this has been acknowledged by other European regions, two more regional groupings started their activities. In the north-east of Europe it is the North East Digital Dividend implementation Platform (NEDDIF) and in the south-east it is the South East Digital Dividend implementation Platform (SEDDIF).

6.2.2 Region 2

In Region 2, there is no regional agreement such as GE06. However, coordination procedures are applied in sub-regional blocks such as MERCOSUR²¹ (Southern Common Market). Some coordination examples in Region 2 are shown below.

6.2.2.1 North America

Coordination in North America is handled through bilateral agreements. These agreements are developed between the various regulatory agencies in the United States (Federal Communications Commission (FCC) and National Telecommunications and Information Administration (NTIA)), Canada (Innovation, Science and Economic Development Canada (ISED)), and Mexico (Secretariat of Communications and Transportation (SCT) and Instituto Federal de Telecomunicaciones (IFT)).

6.2.2.2 MERCOSUR countries

Argentina, Brazil, Paraguay, Uruguay and Venezuela have agreements for coordination procedures in FM and TV frequency bands established by technical committees of the MERCOSUL sub-regional block. Coordination zones and technical criteria were established between the countries and have been successfully applied since the 1990s. Technical meetings are held periodically in order to discuss coordination matters and

²¹ MERCOSUR full members are Argentina, Brazil, Paraguay, Uruguay and Venezuela. Its associate countries are Bolivia, Chile, Peru, Colombia, Ecuador and Suriname.

to harmonise spectrum usage in cross-border zones. As of 2016, procedures for digital TV coordination are in the final stage of approval, which will be an important step for the digital switchover of the region. For those countries that are not included in regional agreements, bilateral or multilateral coordination are needed.

6.2.3 Region 3

In Region 3, although there is no regional agreement such as GE06²², ASEAN²³ countries have their own provision. DTTB implementations in these countries are based on mutual agreement. Countries having cross-border neighbours outside the agreement area negotiate with their neighbouring countries via bilateral or multilateral coordination as needed.

Some coordination examples in Region 3 are shown below.

6.2.3.1 ASEAN

ASEAN countries have agreed to adopt the DVB system. Between some of these countries (for example on the Malaysia-Thailand border, or on the Malaysia-Brunei border), the number of channels available in the VHF and UHF bands for broadcast services are divided equally via bilateral meetings. The same principle is also applied on the Malaysian-Singapore-Indonesia borders in a trilateral meeting. Here the channels are divided equally by three. These countries use 7 MHz bandwidths in the VHF and 8 MHz in the UHF bands.

In addition, Malaysia and Thailand also agreed on a coordination area, within which a DTTB station is required to be coordinated and to be registered in a bilaterally agreed database.

6.2.3.2 China and neighbouring countries

In recent years, China and Russia have been carrying out bilateral meetings on Frequency Planning and Coordination of Digital Terrestrial Television Broadcasting in the Border Areas. The DTTB system operated in China is DTMB while Russia uses DVB-T2. For both countries, each DTTB system channel occupies 8 MHz bandwidths in the VHF/UHF bands.

In order to resolve the incompatibility between the DTTB frequency assignments, one method has been presented as follows. The interference level is classified by three categories: slight interference, medium interference and heavy interference. For the slight interference, it needs both sides to agree whether it is acceptable. If an agreement cannot be reached, DTTB assignments need to take technical measures to eliminate the interference. For the medium interference, possible technical measures should be taken to eliminate the interference or minimize the medium interference to the slight interference. For the heavy interference, it needs both sides to see whether it is possible to eliminate the interference by feasible technical measures. If so, DTTB assignments need to take technical measures to eliminate or minimize the interference. If not, further coordination is required to be carried out. The above method and detailed information refer to the Summary Records of the meetings between China and Russia.

Bibliography to Chapter 6

- [6.1] **ITU-R**, *Final Acts of the Regional Radiocommunication Conference for planning of the digital terrestrial broadcasting service in parts of Regions 1 and 3, in the frequency bands 174-230 MHz and 470-862 MHz (RRC-06)*, Geneva, 15 May – 16 June 2006

²² Except the Islamic Republic of Iran which is situated in the GE06 planning area.

²³ ASEAN member states are Brunei Darussalam, Cambodia, Indonesia, Lao PDR, Malaysia, Myanmar, Philippines, Singapore, Thailand, Viet Nam.

CHAPTER 7

Quality of service for broadcast television

7.1 Overview: The DTTB chain

The DTV system model presented in Figure 7.1 is adapted from that shown in Chapter 1, with the addition of labels to the interfaces between the system components.²⁴

The quality of reception including the picture and sound quality depend on multiple factors. Note that overall service planning includes the whole chain up to IF-4, and includes some assumptions about receiving system performance, such as receiver implementation margin. However, the actual performance of the receiving system cannot be affected by the service planning and is not under the control of the broadcaster or broadcast network operator.

FIGURE 7.1
DTTB System Model

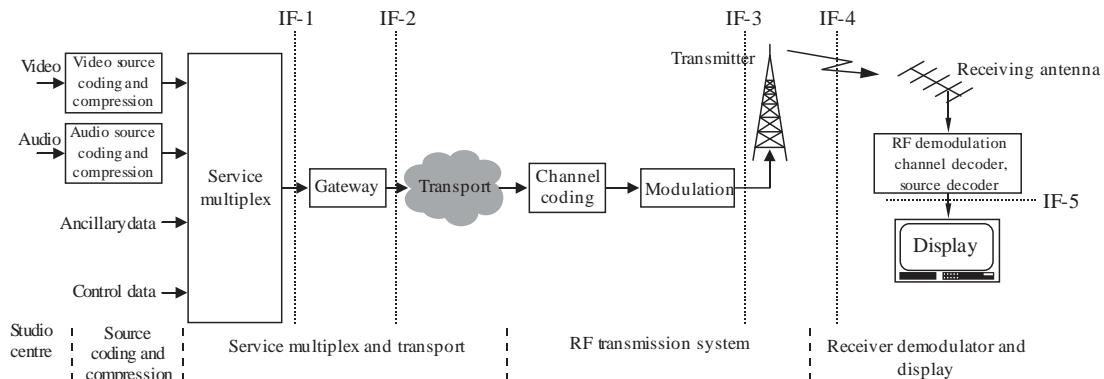

DTTB-07-01

Quality of service requirements can be defined at interfaces IF-1, IF-2 and IF-3. This can be extended by detailed planning making assumptions about the propagation channel and a standard receiving system. In order to avoid the problem that the receiver cannot receive the signal as planned, a minimum receiver specification should be established.

The picture and audio quality is set in the blocks (audio and video source coding and compression) on the left side in the Figure 7.1 above, before IF-1. In DTTB systems, the received picture quality does not change gradually with the quality of the received signal. It will either be full quality, if the signal can be decoded, or no picture at all. Chapter 3 gives indications on the required bitrates for a selection of different video formats.

To improve coverage small transmitters, so called gap-fillers, can be used. These are transmitters that receive the signal from a DTT station. They either retransmit the signal with a very short delay (on-channel repeater or translation to a different frequency) or a regeneration of the RF signal which introduces further delay. These gap-fillers should fulfil certain minimum requirements to ensure quality of service. In some cases, it might be acceptable to have less stringent quality requirements for gap-fillers to improve the cost/benefit ratio for small installations.

²⁴ The “gateway” provides all necessary information to the transmitters, so they can correctly create the RF signals to ensure, inter alia, proper operation of SFNs, PLPs, etc. In DVB-T, a gateway is optional. In DVB-T2, it is mandatory.

7.2 Examples of Specifications to enable Quality of Service

As an example of the necessary information embedded in a data stream in DVB-T, there is a specification for Rules of Operation (RoO) for Nordic countries (NorDig)²⁵, which is also used in Ireland.

The RoO contain a set of minimum transmission rules, which are necessary – in addition to other applicable standards – to support the basic functionalities of the NorDig compliant receivers in primary and secondary networks. It is assumed that the transmissions targeted for such NorDig digital receivers are compliant with the NorDig Unified specifications.

For the operation of a DVB-T2 H.264 SD and HD network, there is also a NorDig receiver specification which can serve as the basis for developing a specific minimum specification.

The NorDig Unified Requirements for Integrated Receiver Decoders (terrestrial part) specifies a set of equipment requirements for reception of DVB-based services. The specifications cover receivers either as separate units (set-top-boxes) or as part of an integrated digital TV set. To simplify checking if the receiver meets the requirements a detailed Test Plan has also been published.

There is also a receiver specification for DVB-T2, H.265 HD in Germany²⁶. It should be noted that the RF related part is identical to the NorDig specification.

When developing minimum requirements that go beyond what has just been referenced, the following ITU-R material provides further guidance.

Recommendation ITU-R BT.1868 [7.1] provides user requirements that can be applied to the specifications, design, and testing of systems for the transmission of television signals. Also, Recommendation ITU-R BT.1122-2 [7.2] provides user requirements for codecs for emission for SDTV and HDTV.

If integrated broadcast-broadband (IBB) systems such as HbbTV are to be deployed as well, Recommendation ITU-R BT.2053 [7.3] recommends that Recommendation ITU-T J.205 (2012) Corrigendum 1 (01/2013) “Requirements for an application control framework using integrated broadcast and broadband digital television” [7.4] should be taken into account when specifying the IBB systems. Appendix 1 of this Recommendation shows which requirements listed in Recommendation ITU-T J.205 are relevant to the broadcast-oriented scenario.

The following Recommendations provide guidance relevant to the sound component of the transmission:

- Recommendation ITU-R BS.775-3 [7.5] recommends one universal multichannel sound system with three front channels and two rear/side channels together with an optional low frequency effects (LFE) channel.
- Recommendation ITU-R BS.1548 [7.6] specifies the requirements relevant to the use of audio source coding systems in sound broadcasting, including television.
- Recommendation ITU-R BS.1909 [7.7] specifies “*performance requirements for an advanced multichannel stereophonic sound system for use with or without accompanying picture. Such a system, or a system derived from it, may find application as the sound components of expanded-LSDI²⁷ and UHDTV programmes.*”

²⁵ These specifications can be found at <http://nordig.org/specifications/>

²⁶ The specification can be found at http://www.tv-plattform.de/images/stories/pdf/MinimumRequirements_DVB-T2_Germany.zip

²⁷ Expanded hierarchy of large screen digital image formats. See Recommendation ITU-R BT.1769.

7.3 Measurements for monitoring QoS

There are multitudes of parameters that need to be monitored to ensure correct delivery of the service.

For DVB-T2, ETSI TR 101 290 [7.8] defines parameters that can be used to monitor signal delivery and identify possible faults. It lists multiple points in the chain where measurements can be undertaken. All those requirements defined, e.g. in ETSI TR 101 290 [7.8], should be monitored to ensure that the quality of service is met.

7.3.1 Measurements at Interface IF-1

At Interface IF-1 in Figure 7.4 the data stream is either a TS (Transport Stream) or a TS encapsulated in IP (Internet Protocol). It contains the video and audio data, as well as service data to be transmitted.

These measurements should be carried out both before the launch of transmission and also during operation. Errors that occur here can have an impact on the reception quality of every receiver.

For DVB-T2, IF-1 is identical to interface A of [7.8]. The measurements to be carried out are detailed in section 5 of ETSI TR 101 290 [7.8].

7.3.2 Measurements at Interface IF-2

At Interface IF-2 in Figure 7.1 the data stream is either a TS (Transport Stream) or a TS encapsulated in IP (Internet Protocol). The gateway has added the information that is necessary for the transmitter to build the required signal.

These measurements should be carried out both before the launch of transmission and also during operation. Errors that occur here can have an impact on the reception quality of every receiver.

For DVB-T2, IF-2 is identical to interface B of ETSI TR 101 290 [7.8]. The measurements to be carried out are detailed in section 11.2 of [7.8].

7.3.3 Measurements at Interface IF-3

Figure 7.1 has defined the interface IF-3 as measured directly at the transmitter output using a directional coupler, or in the laboratory using a signal generator. The signal format is a fully created RF signal.

These measurements should be carried out before the launch of transmission to ensure that the transmitted signal fulfils the requirements.

For DVB-T2, IF-3 is identical to interface C of ETSI TR 101 290 [7.8]. The measurements at the transmitter output to be carried out are detailed in section 11.3 of ETSI TR 101 290 [7.8].

In case Recommendation ITU-R BT.2033 [7.9] does not provide the protection ratio necessary for planning, these can be derived doing lab-measurements at IF-3 using a DTT signal generator. The results can then also be used for the planning the intended coverage.

7.3.4 Measurements at Interface IF-4

Interface IF-4 is defined as the interface where measurements are carried out in the field. The signal format is the same as the RF signal emitted from a DTT station but it will have been altered by the effects of the RF propagation channel.

However, compared to interface IF-3 not all measurements are necessary in the field. The focus should be on the received field strength and signal quality parameters. These can then be used to verify or improve the coverage modelling and therefore improve the quality of service.

For DVB-T2, IF-4 is identical to interface C of ETSI TR 101 290 [7.8]. The measurements to be carried out are detailed in section 11.3 of [7.8].

7.3.5 Measurements at Interface IF-5

At Interface IF-5 in Figure 7.1, the data stream is either a TS (Transport Stream) or a TS encapsulated in IP (Internet Protocol). It contains the video and audio data, as well as service data.

There are two scenarios where such measurement can be applied to ensure quality of service. In either case, a measurement receiver is necessary to analyse the TS data.

One scenario is the operation of remote network monitoring, where a measurement somewhere in the field not only monitors RF signal strength and quality as specified for interface IF-4 but also makes measurements at the TS level.

The other scenario can be lab-testing of receivers, to check if a domestic receiver works correctly with the specified signal. This can involve a measurement receiver that checks if the signalling is correct and then a further check on the domestic receiver under test to ascertain that the receiver is functioning correctly. For example, it can be checked whether the transmitted information can be accessed or if the picture is decoded correctly.

For DVB-T2, IF-5 is identical to interface D of ETSI TR 101 290 [7.8]. The measurements to be carried out are detailed in section 5 of ETSI TR 101 290 [7.8].

7.4 Examples for transmission quality in digital television

Examples for estimation of quality of transmission at the level of the modulated signals and at the level of MPEG transport stream are given in Report ITU-R BT.2389 [7.18]. For examples of coverage estimation, see [7.10] to [7.17].

7.5 Redundancy as a means of maintaining QoS

Fulfilling each of the requirements set out above and monitoring them will not ensure the quality of service unless the basic infrastructure of the DTT transmitting stations also meets certain requirements.

To ensure very high time availability it is necessary to consider at least three more aspects:

- **Power Supply:** The “standard” electricity supply grid may not be constantly available, so it may be necessary to operate an additional onsite generator to keep the outages to a minimum.
- **Primary Distribution:** The primary distribution which feeds signals across the interfaces IF-1 and IF-2 should also meet a required minimum availability. The reliability of either interface can be maximized by co-locating the equipment on either side of the interface, shortening the distance the signal has to travel. However, in the case of IF-2, the signal will normally need to be sent to one or more remote transmitter locations. It can be very expensive to improve a single distribution circuit to the desired level. It might therefore be more effective to supply a second distribution circuit to ensure very high availability.
- **Failure of System components:** Availability can be improved by having reserve equipment available. This can be an additional transmitter, or transmitter components, that can start operation in case of an equipment failure. In extreme cases, a separate fully-equipped transmission site in close proximity to the main might be provided.

The actual redundancy concept depends on a number of economic and operational aspects. It is determined by the importance of a particular DTTB station (normally determined by population coverage).

A risk analysis can be a useful starting point when determining the availability target.

Bibliography to Chapter 7

- [7.1] **ITU-R**, Recommendation ITU-R BT.1868, *User requirements for codecs for transmission of television signals through contribution, primary distribution, and SNG networks*
- [7.2] **ITU-R**, Recommendation ITU-R BT.1122-2, *User requirements for codecs for emission and secondary distribution systems for SDTV and HDTV*
- [7.3] **ITU-R**, Recommendation ITU-R BT.2053, *Technical requirements for integrated broadcast-broadband systems*
- [7.4] **ITU-T**, Recommendation ITU-T J.205 (2012) Corrigendum 1 (01/2013), *Requirements for an application control framework using integrated broadcast and broadband digital television*
- [7.5] **ITU-R**, Recommendation ITU-R BS.775-3, *Multichannel stereophonic sound system with and without accompanying picture*
- [7.6] **ITU-R**, Recommendation ITU-R BS.1548, *User requirements for audio coding systems for digital broadcasting*
- [7.7] **ITU-R**, Recommendation ITU-R BS.1909, *Performance requirements for an advanced multichannel stereophonic sound system for use with or without accompanying picture*
- [7.8] **ETSI** TR 101 290: *Digital Video Broadcasting (DVB); Measurement guidelines for DVB systems*
http://www.etsi.org/deliver/etsi_tr/101200_101299/101290/01.03.01_60/tr_101290v010301p.pdf
- [7.9] **ITU-R**, Recommendation ITU-R BT.2033, *Planning criteria, including protection ratios, for second generation of digital terrestrial television broadcasting systems in the VHF/UHF bands*
- [7.10] **ITU-R**, Recommendation ITU-R BT.1125, *Basic objectives for the planning and implementation of digital terrestrial television broadcasting systems*
- [7.11] **ITU-R**, Recommendation ITU-R BT.1735-1, *Methods for objective reception quality assessment of digital terrestrial television broadcasting signals of System B specified in Recommendation ITU-R BT.1306*
- [7.12] **ITU-R**, Recommendation ITU-R SM.1875, *DVB-T coverage measurements and verification of planning criteria*
- [7.13] **ITU-R**, Report ITU-R BT.2035, *Guidelines and techniques for the evaluation of digital terrestrial television broadcasting systems*
- [7.14] **ITU-R**, Report ITU-R BT.2137, *Coverage prediction methods and planning software for digital terrestrial television broadcasting networks*
- [7.15] **ITU-R**, Report ITU-R BT.2143, *Boundary coverage assessment of digital terrestrial television broadcasting signals*
- [7.16] **ITU-R**, Report ITU-R BT.2248, *A conceptual method for the representation of loss of broadcast coverage*
- [7.17] **ITU-R**, Report ITU-R BT.2252, *Objective quality coverage assessment of digital terrestrial television broadcasting signals of Systems A and B*
- [7.18] **ITU-R**, Report ITU-R BT.2389, *Guidelines on measurements for digital terrestrial television broadcasting systems*

CHAPTER 8

Satellite assistance

8.1 Introduction

This Chapter describes how satellites can assist the provision of digital terrestrial television broadcasting services.

For large area coverage (national and international), television broadcasting via satellite is commonly in use. Such Broadcasting Satellite Service (BSS) is not the subject of this Handbook, and specific information on BSS is available in the documentation of ITU-R Study Group 4.

Satellites, especially in the fixed satellite service (FSS) and in the mobile satellite service (MSS), are nevertheless of significant importance to the terrestrial television broadcasting service. For example, satellites can be used to feed DTTB transmission networks; they are also helpful as return channels in interactive television in cases where no other telecom networks are available for that purpose. Broadcasting satellites and terrestrial TV broadcasting can, in principle, cooperate to optimize the broadcasting coverage. Such concepts are often called hybrid broadcasting although the term itself is not defined in the ITU Radio Regulations, and applications of such schemes are currently only known for digital sound and data broadcasting.

NOTE – A very useful application for the production of television is satellite news gathering (SNG), a specific form of ENG, which is dealt with in more detail in Chapter 15.

8.2 Satellites as feeder-links for terrestrial television broadcasting networks

A centrally generated broadcast multiplex can be distributed via an FSS satellite in order to feed a terrestrial broadcasting network. This is especially useful for large broadcasting service areas and when terrestrial feeder-links such as optical fibres or wireless relay links are not available.

Depending on the satellite frequency used, drop-outs may occur during heavy precipitation or when wet snow or ice accumulates in the parabolic receiving antenna at the broadcasting transmitter station. At frequencies higher than about 10 GHz, rain attenuation can lead to interruptions on the down-link. An uplink in Ku or Ka band is more stable, as power control and space diversity transmission be applied in case of signal attenuation.²⁸ With satellite feeding, a high percentage of reliability can be achieved. 100 percent viability cannot, however, be guaranteed.

In case of feeding a terrestrial SFN, due care has to be applied to compensate for the differences in propagation time at the various receiving sites. The path length between the satellite and each terrestrial broadcasting transmitter varies and varies the propagation time for the satellite signal also varies. Typical time differences are in the order of micro-seconds. For SFNs, one must assure that the time of emission is nominally equal at each terrestrial transmission site (note however that specific time shifts can be used for optimum SFN operation as described in Chapter 4). The received satellite signal should thus be cached for synchronous emission. For that purpose, the time reference provided by navigation satellites is often used. If time synchronization is not observed, part of the guard interval is lost and hence the resilience of the broadcast COFDM signals against multi-path interference.

²⁸ Power control increases the uplink power of the satellite Earth station in accordance with the measured signal attenuation during rain showers. A second Earth station located at a significant distance from the main station can be used as a spare and when rain showers at the main station are so heavy that power control is not sufficient to overcome the attenuation. Of course, the spare station needs to be connected to the main station via a reliable link that is not subject to rain attenuation, e. g. via optical fibre or radio links operating at frequencies below 10 GHz.

8.3 Using satellites as IP return channels for interactive television

In modern terrestrial television, interactivity needs an additional connection of the TV set or the TV set-top box to a telecommunication network, typically an IP based broadband network that allows access to the internet (WLAN, DSL, mobile network, etc.). In cases where such a terrestrial network is not available, access can often be achieved via a VSAT station that provides, at the consumer premises, such IP access via satellite. The parabolic antenna is equipped with a frequency diplexer that allows the satellite up and down-links to be decoupled. As the uplink is normally limited to low data-rates (e.g. request for content), the transmit power of such VSAT stations can be relatively low (a few watts) as well as the diameter of the parabolic antenna (of the order of one meter at Ku band).

More information on interactivity and the systems used for integrated broadcast-broadband applications can be found in Chapter 10.

8.4 Joint usage of the terrestrial and the satellite broadcasting

TV content is provided to terminals either through terrestrial infrastructures or, alternatively, through satellite distribution. With the introduction of TV mobile reception and more generally multimedia applications, there is a requirement from users for continuity of service that can be offered by hybrid systems combining satellite broadcasting and terrestrial broadcasting that use common RF chipsets receiving either satellite or terrestrial transmissions and based upon SDR technologies.

There are two types of system structures: Hybrid satellite/terrestrial system and Integrated MSS systems, as explained in the following definitions. These texts are provided as examples and to illustrate the principle of such systems, as they are currently only used for radio/data broadcasting.

8.4.1 Definition of a Hybrid Satellite/Terrestrial System

According to ETSI, a hybrid satellite/terrestrial system is a “system employing satellite and terrestrial components where the satellite and terrestrial components are interconnected, but operate independently of each other. In such systems the satellite and terrestrial components have separate network management systems and do not necessarily use the same modulation” [8.1]. Additionally, it should be noted that the two components do usually not operate within the same frequency band.

For example, the combination of satellite and terrestrial infrastructure optimizes the investment costs by offering a signal over sparsely populated areas, while in densely populated areas, where the satellite signal is more difficult to receive, terrestrial infrastructure is used to deliver the same content in the same band. This terrestrial infrastructure may broadcast local programmes in addition of those broadcast by the satellite.

8.4.2 Definition of an Integrated MSS System

According to ETSI and ITU-R, an integrated MSS system is “a system employing a satellite component and a ground component where the ground component is complementary to the satellite component and operates as and is an integral part of the MSS system. In such systems, the ground component is controlled by the satellite resource and network management system. Further, the ground component uses the same portions of MSS frequency bands as the associated operational mobile-satellite system.” [8.1], [8.2], [8.3]

Such systems are referred to as MSS-ATC (MSS-Ancillary Terrestrial Component) in the United States and Canada, and MSS-CGC (MSS-Complementary Ground Component) in Europe and are implemented in the 1-3 GHz bands.

As shown in Figure 8.1, the ground component of an Integrated System is not an independent stand-alone network and it uses the same frequencies assigned to the satellite component, although the two components do not necessarily use the same frequencies simultaneously in the same geographic area. This spectrum sharing provides a more useful service by improving overall spectrum efficiency by permitting greater frequency reuse. This in turn allows economies of scale that are important to reduce network costs.

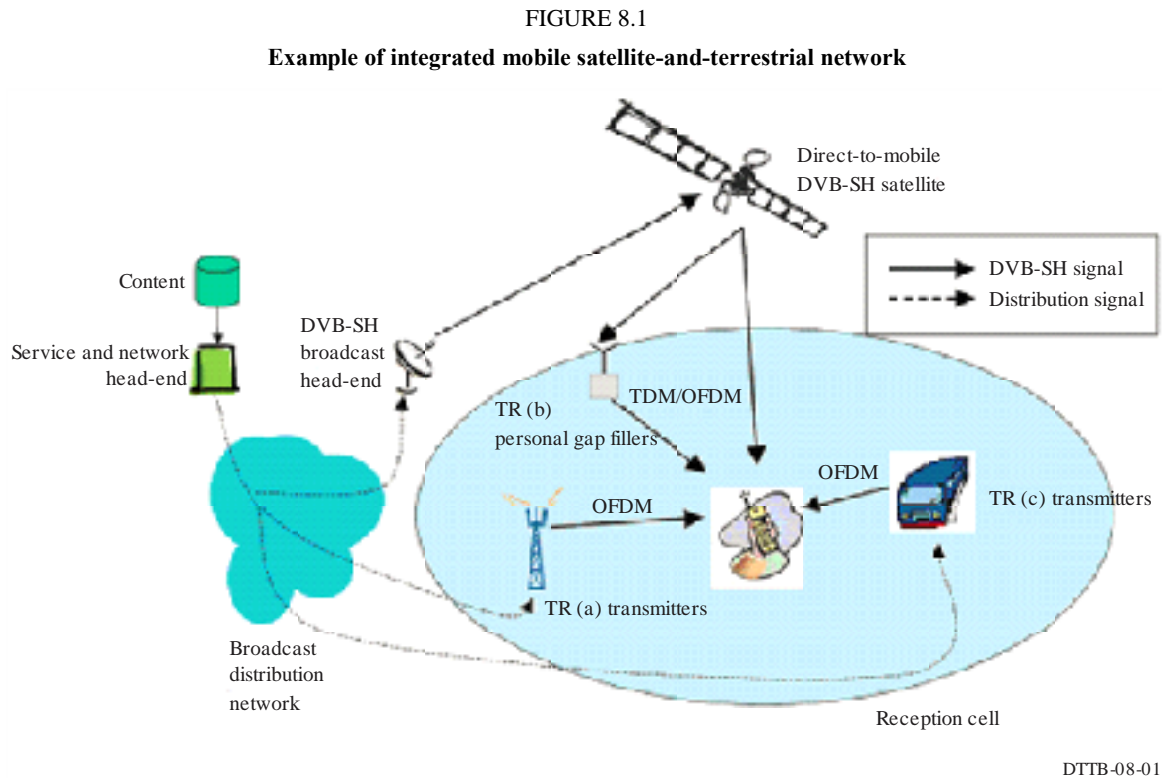

Bibliography to Chapter 8

- [8.1] **ETSI TR 103 124** *Satellite Earth Stations and Systems (SES); Combined Satellite and Terrestrial Networks scenarios*
- [8.2] **ITU-R** Vocabulary:
<http://www.itu.int/net/ITU-R/asp/terminology-definition.asp?lang=en&rlink={FB87FE16-E1BC-42E6-92BC-567849F31903}>
- [8.3] **ITU-R**, Report ITU-R BS.2173, *Multi-carrier based transmission techniques for satellite systems*

PART 2

SYSTEM ASPECTS

Introduction to Part 2

Whilst Part 1 dealt with the networking aspects of digital terrestrial television broadcasting (DTTB) in general and mainly in system independent form, Part 2 concentrates on the system aspects. Part 2 starts from a detailed and comprehensive description of the various terrestrial digital broadcasting systems, then deals with interactivity and collaboration between broadcasting and broadband technologies, and gives information on conditional access including content protection.

In digital signals, audio-visual quality is determined differently in comparison to the analogue television service. Whilst the latter is highly dominated by transmission noise and interference, the digital signal does not suffer from such disturbances as long as certain levels of noise and interference are not exceeded. In contrast, there is no such thing as graceful degradation. Owing to the forward error corrections, there is less than one decibel of margin between perfect reception and total failure. Visible artefacts (such as judder) are due to the compression system used as applied in the broadcasters' playout and coding systems.

Of course, receivers need to perform adequately. Their functions are described in a specific chapter. An important issue concerns access services for people with disabilities or special needs. Digital television offers more possibilities and easier realization for these services that are of help to all of us, not only to people with disabilities.

CHAPTER 9

Systems for digital terrestrial television broadcasting

9.1 Broadcast system technologies

9.1.1 Service multiplex and transport methods

9.1.1.1 Introduction

In contrast to analogue television broadcasting, where television programme components (such as the picture or the accompanying sound, etc.) are transmitted separately, digital broadcasting systems are based on the principle of the simultaneous combined transmission of video, sound, data and control signals.

In analogue broadcasting systems, video and sound for any programme are transmitted in separate with frequency channels, on the principle that one programme signal occupies the whole channel bandwidth (Figure 9.1).

In digital broadcasting systems, simultaneous transmission mode within one frequency channel is used to deliver data streams containing packets generated from audio and video information from one or more programmes (Pr. 1, Pr. 2 ... Pr. n), and additional data streams, with virtual time and frequency bandwidth segmentation (Figure 9.2).

FIGURE 9.1

Principle of multi-programme transmission in analogue broadcasting systems

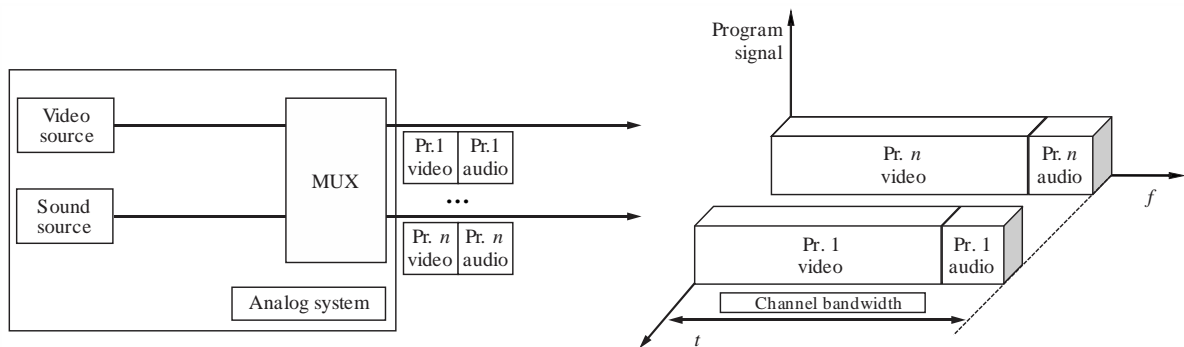

DTTB-09-01

FIGURE 9.2

Principle of multi-programme transmission in digital broadcasting systems

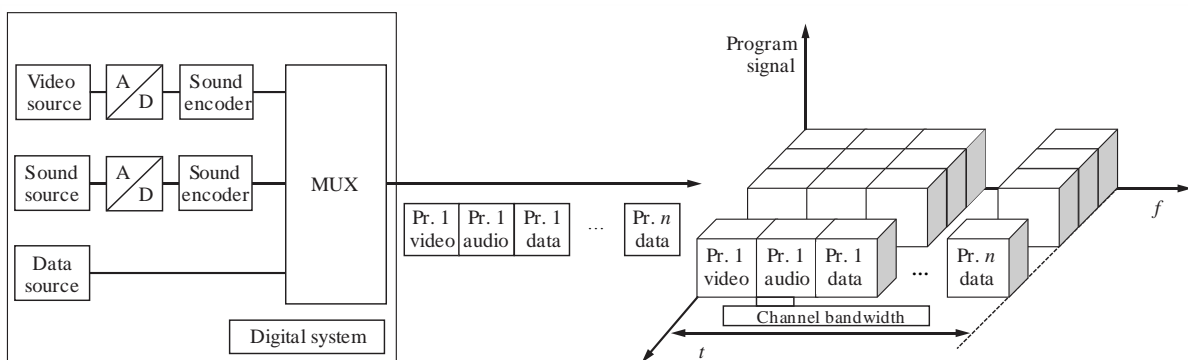

DTTB-09-02

It became possible to provide simultaneous transmission of multiple programmes' components by the use of digital signal processing techniques, digital telecommunication technologies and, particularly, data reduction methods based on redundancy specific for certain type of media (e.g. visual redundancy, psychoacoustic redundancy and statistical redundancy). Combined use of all these technologies made possible the increasingly efficient use of the radio spectrum and thus a significant reduction of the channel capacity required for information transmission.

9.1.1.2 Service multiplex methods

In DTTB, one or more digital multiplexes may carry a number of television services, each comprised of one or more video components, one or more audio components, and optionally other components such as ancillary data. It is also necessary to transmit additional data that enables the user equipment to locate the service of interest (and the components of interest within that service), and to enable the user equipment to create a suitable navigation environment for user-friendly access to the available digital services.

Service multiplexing can be implemented using structured transmission (fixed assigned method), packet transferring (variable assigned method), or a combination of both. Such approaches have significant advantages for various service implementations.

Fixed and variable length packet multiplexing. The overall system multiplexing approach can be thought of as a combination of multiplexing at two different layers. In the first layer (programme layer), single program bit streams are formed by multiplexing packets from one or more elementary bit streams (Figure 9.3), and in the second layer (transport layer), a number of single program bit streams are combined to form one or more transport stream(s).

At the source encoder output (video and audio encoders) information is organized as series of a separated streams, called Elementary Streams (ES) (Figure 9.3).

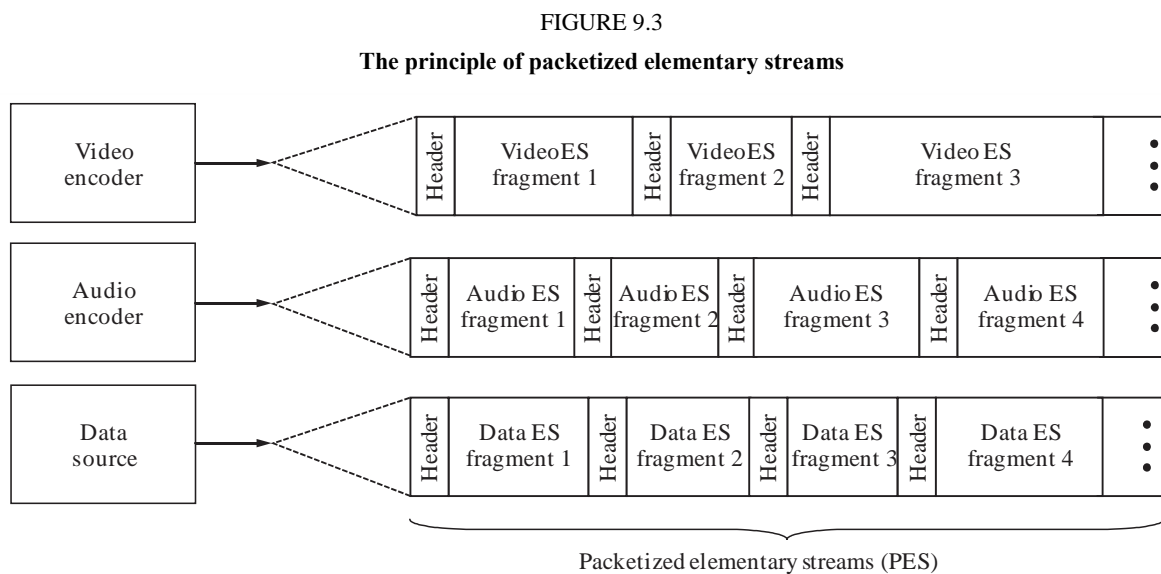

DTTB-09-03

Each of these elementary streams is packetized, because it is formed by a series of variable length packets, which each contain a certain portion of information about the transmitted image, sound sequences or data. In digital television broadcasting systems, data streams can be transmitted as in the PES stream payload or by use of other mechanisms, defined in section 9.1.4.

Elementary stream packet length depends on many factors, such as content criticality to the compression, source encoder buffer overlap, etc. The maximum packet capacity is limited to 64 kByte.

The structure of the PES packet with an indication of the basic elements is shown in Figure 9.4. The PES packet consists of the header, and the followed elementary stream of video or audio signals standardized by the Moving Pictures Expert Group (MPEG) or the elementary stream for data services, and its length is variable (both the header and the content of the packet are variable).

PES-packet headers consist of mandatory and optional parts. In the mandatory part of PES packet header, that has length 6 bytes, information about the packet beginning (3 bytes) (indicates the start of the PES packet), stream identifier, defining type of the stream, which fragment is being carried in this PES-packet (1 byte), and packet PES length value (2 bytes) are given.

FIGURE 9.4
PES-packet structure

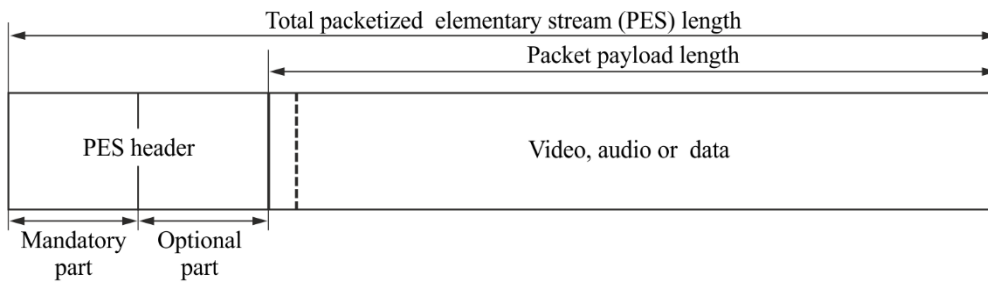

DTTB-09-04

The availability of the optional part of a PES header depends on the application’s requirements. If applied, this variable length part of the header contains information about use of scrambling in the elementary stream, whether the material of the associated PES packet payload is copyrighted or not, whether the contents of the PES packet payload is an original or copy, the total number of bytes of the optional fields and stuffing bytes contained in this PES packet header. In addition different optional fields may be applied, particularly, fields, containing information on the presentation time stamp (PTS) and on the decoding time stamp (DTS), that are necessary for audio and video synchronization.

In detail, PES packet format, and also the limitations for different types of streams (video PES streams, audio PES streams) are defined in Recommendation ITU-R BT.1209-1 [9.1].

For a single program bit stream, forming the multiplexed bit stream requires that individual packetized elementary bit streams (PESs) are combined with individual packet identifiers (PID) sharing a common time-base, and a packetized control bit stream (service information sub-channel) that describes the program.

FIGURE 9.5
Illustration of multiplexing to form a single program stream

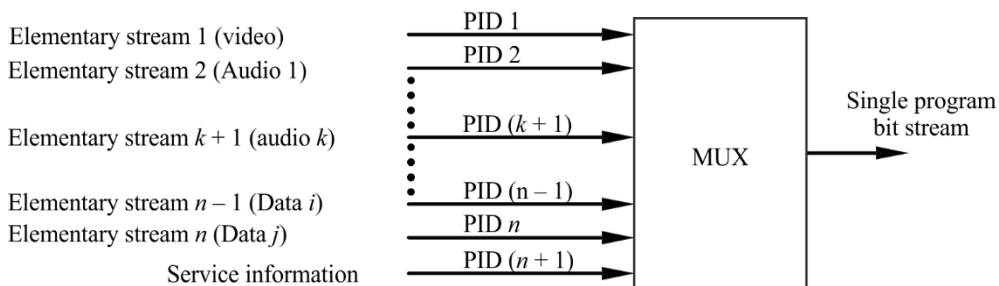

DTTB-09-05

For digital multimedia broadcasting systems, a special multiplexing scheme with variable-length packets – called type-length-value (TLV) multiplexing – is defined. Specifications are given for schemes for transporting IP packets over broadcasting channels: encapsulation format, header compressed IP packet format, and transmission control signals. For more details see Recommendation ITU-R BT.1869 [9.2] and [9.78, 9.86].

Statistical multiplexing. Audiovisual information compression codecs with Variable Bit-Rate (VBR) coding have widespread use. In such codec compression, an algorithm is used to allocate a certain data capacity for picture scenes that are critical to compression quality. Otherwise, fewer bits are used.

This leads to the possibility of bit-rate variation at the audio or video encoder output depending on the nature of the scene or the sound sequence being processed, or depending on requirements of the particular program. However, for further processing in the broadcast system it is often necessary to obtain a time-independent bit-rate. For provision of this, padding information is added to the data. Under such conditions, however, the efficiency of spectrum use decreases.

In digital broadcasting, it is highly desirable to use the available channel capacity in an effective and efficient way. Due to the fact that the bit rate required to obtain a desired picture quality depends on picture content, the use of constant bit rate coding leads to large variations in picture quality, and an inefficient use of channel capacity. This suggests that a variable bit rate compression scheme that allows the channel capacity to be dynamically allocated between programmes would result in improved overall picture quality and/or bandwidth savings. In order to perform bit allocation across programmes, a control mechanism known as joint coding control has to be introduced. This technique is referred to as statistical multiplexing (although in conventional statistical multiplexing there is no global control mechanism).

The MPEG encoders available on the market today are designed to support a variable output data rate. In a multi-programme environment, the data rates of several multiplexed programmes can be jointly controlled in such a way that the desired picture quality of each programme is achieved by using a variable bit rate encoding scheme, while maintaining the aggregate bit rate constant at the channel rate.

Basic principles and requirements to statistical multiplexing are defined in Recommendation ITU-R BT.1437 [9.3] and Recommendation ITU-T J.180 [9.4].

It is therefore possible to increase channel use efficiency to some extent by the use of statistical multiplexing (Figure 9.6).

FIGURE 9.6
Example of statistical multiplexing

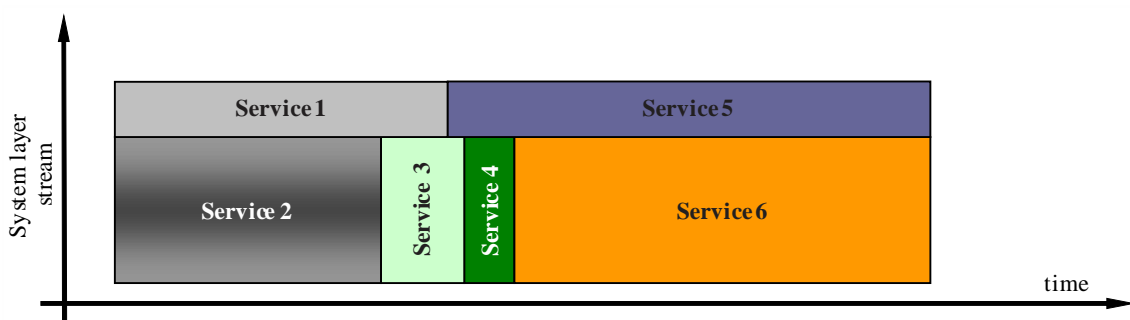

DTTB-09-06

In the case of statistical multiplexing, common channel resource allocation to services carried in the system layer stream (Service 1 to Service 6 in Figure 9.6), depending on required bit-rate in each of portions of time, is performed. In this case, the channel resource is used in more efficient way than in the case of fixed multiplexing, when each service is allocated a fixed channel volume. One of the disadvantages of statistical multiplexing is the complexity of the control systems as compared with the usual fixed multiplexing method, and channel resource allocation requiring additional scheduling, while still ensuring access of all services to the channel resource. In addition, the situation may occur, when the unanticipated reduction of the resource

assigned to one broadcaster's programs leads to quality reduction or other inconvenience to other broadcasters sharing the same multiplex resource.

In case of second generation DTTB systems the special statistical multiplexing scheme called physical-layer pipe (PLP) is used. A PLP may be a logical or a virtual sub-channel organized within a particular physical channel. PLPs are used to carry the service data and signalling data for other layers than L1 (Physical layer).

Each service PLP enables the transport of data independently of its structure, with freely selectable and specific robustness specific to the physical parameters of the PLP used (see Figure 9.7) [9.87]. Such an approach gives the possibility of implementing the service-specific protection and more efficient usage of channel resource based on the required typical service protection level and modulation format (see Figure 9.8) [9.71].

FIGURE 9.7
DVB-T2 system concept of fully transparent physical-layer pipes

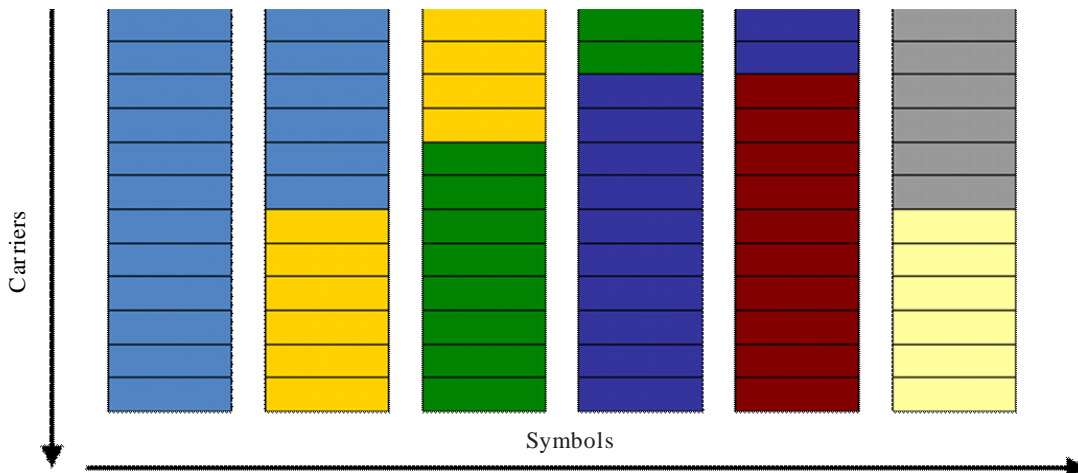

DTTB-09-07

The DVB-T2 specification [9.8] allows a constellation, code rate and time-interleaving depth to be assigned to each single PLP individually. Furthermore, the formatting of the content follows the same baseband-frame structure as that employed by DVB-S2. Both the allocated capacity and the robustness can be adjusted to the content/service providers' particular needs, depending on the type of receiver and the usage environment to be addressed.

FIGURE 9.8
Service-specific concept based on PLPs

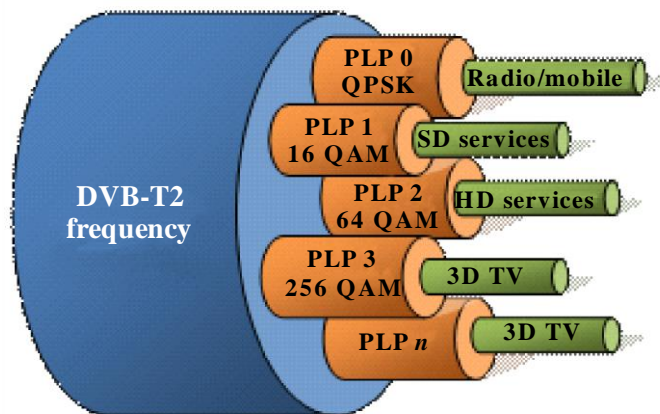

DTTB-09-08

There are two types of PLPs: common PLPs (which contain common information for several PLPs (also called as group of PLPs), e.g. service or other information) and data PLPs of type 1 and type 2. The data PLPs are intended to carry the actual T2 services. The difference between the two types of data PLPs lies with the possibilities of sub-slicing and power saving.

Hence, receivers need to decode up to two PLPs at the same time when receiving a single service: the data PLP and its associated common PLP.

Two general input modes are defined: input mode A uses a single PLP (this case is typical for first generation digital broadcasting systems), whilst input mode B uses multiple PLPs (Figure 9.9).

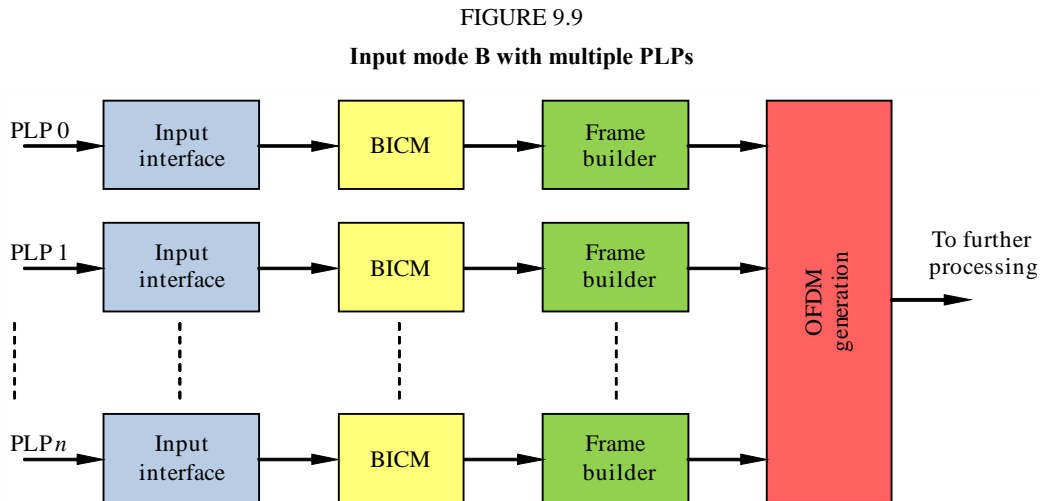

DTTB-09-09

It may be desirable for the common PLP of a group to use different modulation and coding from the data PLPs, to compensate for the reduced time diversity of a common PLP compared to the type 2 PLPs with their multiple sub-slices. This can be accommodated if the common data is arranged to have a fixed data rate.

A DVB-T2 system may contain different groups of PLPs each with different coding and modulation, provided the total bit-rate within each group is constant.

More advanced statistical multiplexing could in principle be performed between PLPs with different code rates or modulation. In the case of different code-rates, the statistical multiplexer would need to allocate bits to each service in proportion to the code-rate of the associated PLP, so that the total gross bit-rate remained constant. Using the “one big transport stream” model, the big TS would have a rate corresponding to the entire capacity being given to the PLP of the highest code-rate.

Sliced multiplexing. (Also called sliced multiplexing with portioning of system stream in the time, frequency or time-frequency domain.) The objective of time slicing is to reduce the average power consumption of the terminal and enable smooth and seamless service handover.

When using time slicing, multiplex is organized as shown in Figure 9.10.

FIGURE 9.10
Time-slicing principle

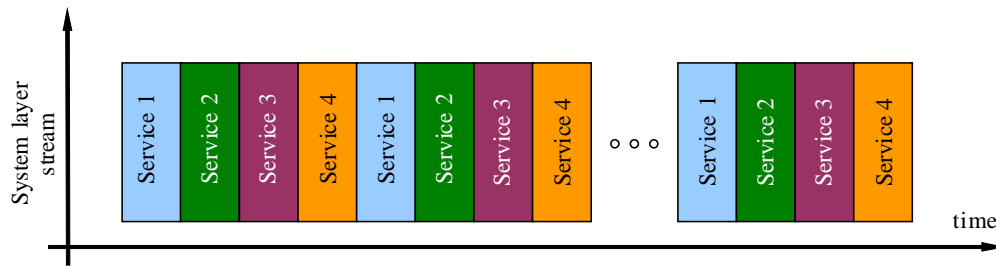

DTTB-09-10

In the case of such multiplex organization, the original digital stream of each service is divided into slices, whose sizes are sufficient for provision of continuous information presentation to the user. Each of these slices is transmitted during certain short time intervals. Different services' streams are transmitted slice by slice and the interval between consecutive slices of one service is not exceeded by the time necessary for reception, decoding and presentation of the information carried by the slice. Time slicing enables a receiver to stay active for only a fraction of the time, i.e. when receiving bursts of a requested service.

Several variants of time-slicing realization in digital terrestrial broadcasting exist: using a dedicated multiplex, a mixed multiplex or hierarchical transmission.

Figure 9.11 shows the variant of time slicing implementation based on a dedicated multiplex with Multi-Protocol Encapsulation (MPE) for the case of IP-only services transmission.

The IP encapsulator is assumed to take responsibility for generating MPE sections from incoming IP datagrams, as well as adding the required PSI/SI data. The output stream of the IP encapsulator is composed of MPEG-2 transport packets.

FIGURE 9.11
Example of time-slicing implementation with use of dedicated multiplex

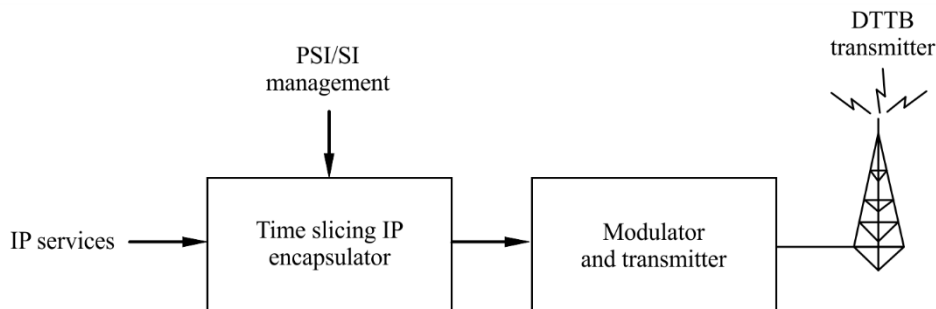

DTTB-09-11

As there are no other services (i.e. no non-time-sliced services), the functionality remains simple. Time slice bursts are generated in the IP encapsulator. A burst may use the maximum bit-rate. Any "off period" (that is, time when no data bursts for any elementary stream are transmitted) may be filled with null packets. PSI/SI sections may be spread over the transport stream by allocating a constant bit-rate for it.

Figure 9.12 illustrates the construction of a head-end for the transmitted multiplex containing both IP services and other (digital-TV) services. The major difference from the case of a dedicated multiplex is the requirement for a multiplexer.

FIGURE 9.12

Example of time-slicing implementation with use of mixed multiplex

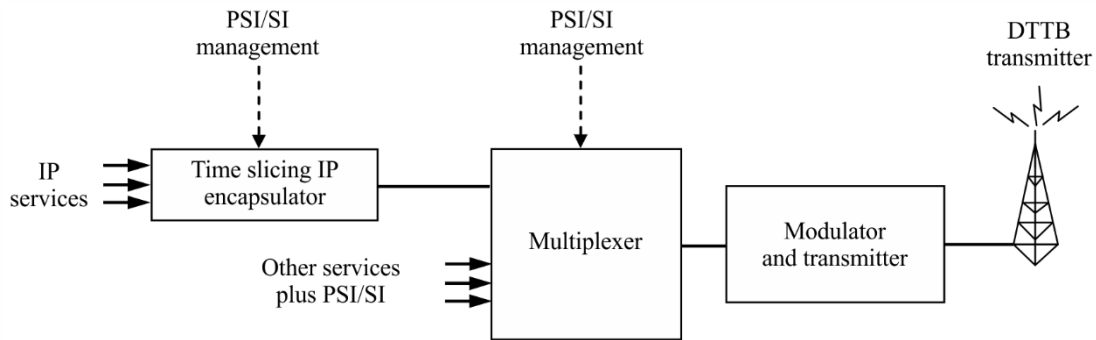

DTTB-09-12

One possible way to avoid mixing time-sliced and non-time-sliced streams in a common multiplex – and thus to avoid the use of a multiplexer – is to use a hierarchical transmission mode. In this case, the multiplex containing time-sliced services is transmitted at a high priority – ensuring better robustness in a mobile environment – while the multiplex for non-time-sliced services is transmitted at a low priority – giving a higher bit-rate for fixed reception services. This effectively supports two multiplexes within a single transmission. A simplified block diagram showing support for hierarchical transmission is depicted in Figure 9.13.

FIGURE 9.13

Variant of time-slicing realization with use of hierarchical transmission

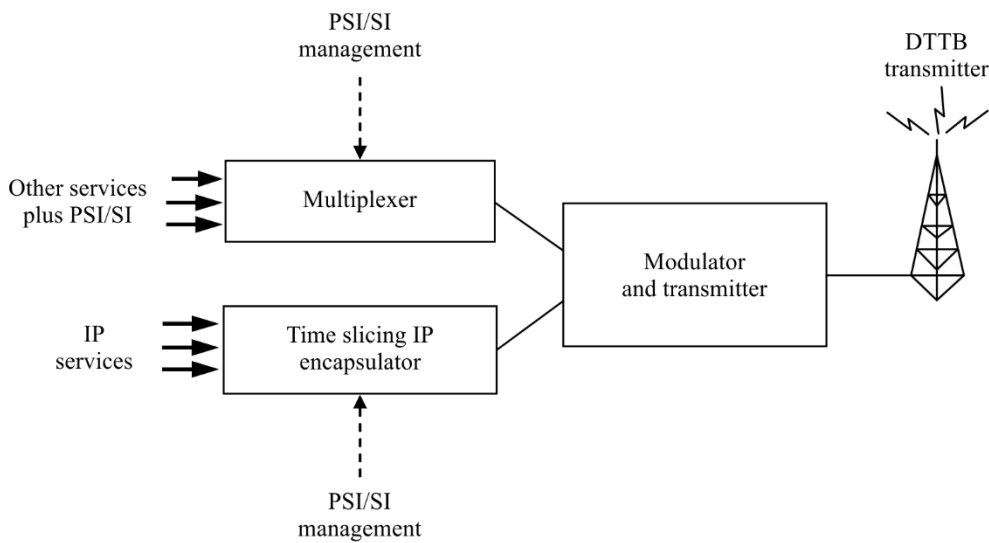

DTTB-09-13

Time-Frequency-Slicing (TFS) of second generation DTTB is defined in [9.8]. TFS is a method where the sub-slices of a PLP are sent over multiple RF frequencies during the system frame. This introduces two-domain statistical multiplexing – either in time and frequency.

The basic block diagrams given in Figure 9.14 apply when TFS is used, but the frame builder and OFDM generation modules are modified to include additional chains so that there is one branch for each of the N RF channels of the TFS system.

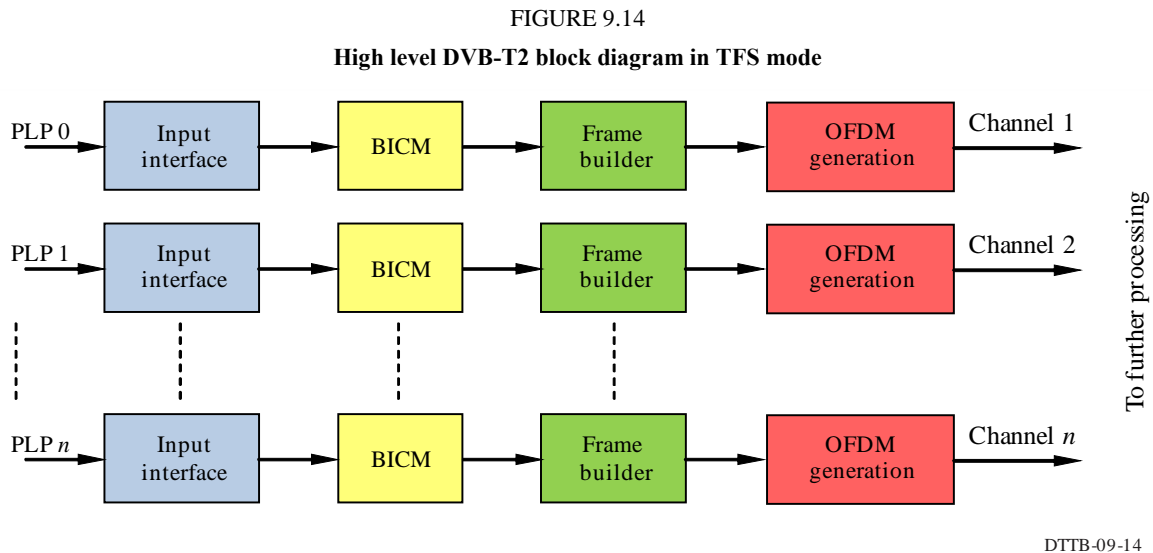

In the case of TFS the maximum bit rates correspond to those in normal mode of operation. However, if applied, TFS provides more flexible statistical multiplexing and improved receiver performance in terms of link budget and more efficient signal processing in MIMO/SIMO modes on the receiver side.

More information about TFS is available in EBU Technical Report 35 [9.5]

9.1.1.3 Service transport methods

The second layer of multiplexing is multiplexing program streams to form a single stream, which is called the Transport Stream (TS).

Terrestrial digital television and multimedia broadcasting systems for simultaneous transmission of different data types, independent on channel bandwidth, currently use MPEG-2 transport stream, defined in Recommendation ITU-T H.222.0 [9.6], Standard ISO/IEC 13818-1 [9.7], MPEG Media Transport (MMT) [9.75] or Baseband (BB) stream, defined in ETSI EN 302 755 [9.8] (see also Recommendation ITU-R BO.1784 [9.9] and ETSI EN 302 307 [9.151]).

MPEG-2 transport stream multiplexing. In developing the transport mechanism, interoperability among digital media, such as terrestrial broadcasting, cable distribution, satellite distribution, recording media, and computer interfaces, is a prime consideration. ITU-R recommends that digital television systems employ the MPEG-2 TS syntax for the packetization and multiplexing of video, audio, and data signals for digital broadcasting systems. The MPEG-2 TS syntax (see Recommendations ITU-R BT.1207 [9.10] and ITU-R BT.1209-1 [9.1], Recommendation ITU-R BT.1299 [9.25]) was developed for applications where channel bandwidth or recording media capacity is limited and the requirement for an efficient transport mechanism is paramount.

Framing, transmission and data identification methods within multi-programme stream in the MPEG-2 TS-based digital terrestrial television broadcasting systems are defined in Recommendation ITU-R BT.1300-3 [9.11]. It covers issues on the means of dividing the digital data stream into “packets” of information, the means of uniquely identifying each packet or packet type, and the appropriate methods of multiplexing video data stream packets, audio data stream packets, and ancillary data stream packets into a single data stream consisting of a sequence of 188-byte TS packets.

The system layer of multiplexing in the case of single transport stream mode is presented in Figure 9.15.

Packetized program streams (PS), containing information about video (V), audio (A) or data (D), formed on the previous system level, are provided to an MPEG-2 transport stream multiplexer, where PS variable length packet mapping into packetized transport stream format with fixed packet length is performed.

FIGURE 9.15
MPEG-2 transport stream forming

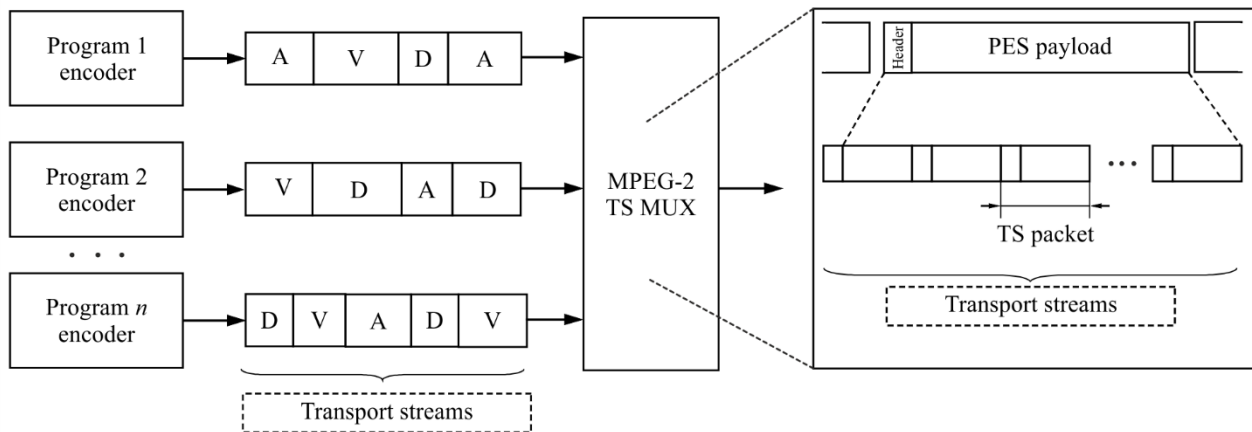

DTTB-09-15

One PES packet is distributed on several transport stream packets. Considering that PES packet length in bytes is not always multiple of 184, some transport packets (which contain PES packet remainders) will be only partially filled. The remaining parts of those transport packets are padded by an *adaptation field*, the length of which equals difference between 184 bytes and PES remainder. Such adaptation fields are used (in some cases) as in-built delivery channel for some service information (e.g. Program Clock Reference stamps).

A transport stream is optimized for transmission over a broadcast environment, as it provides a constant bit-rate at the output of the transport multiplexer. Taking into account that streams at the input of the transport multiplexer may be of Variable Bit-Rate (VBR), for transition to Constant Bit-Rate (CBR) the insertion of null-packets is performed (see Figure 9.16).

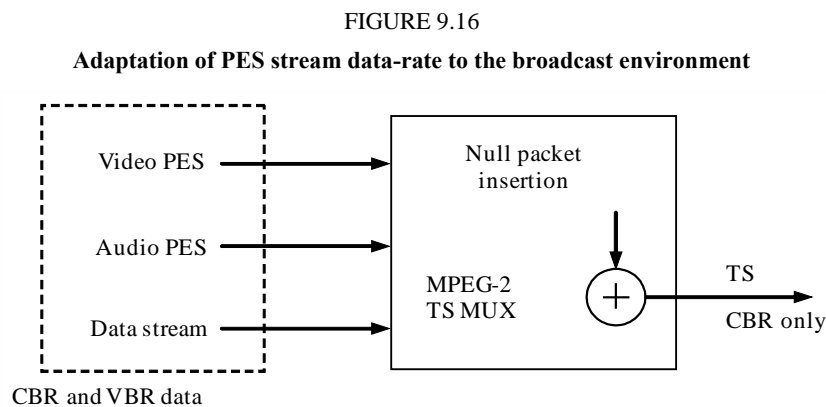

DTTB-09-16

In some applications, the null-packets are used as an embedded measurement channel for transmission test signals or diagnostic information.

Current progress in telecommunication and broadcast technologies allows transmission within digital television broadcasting system not only of one transport stream, but also of several transport streams, the number of which is limited only by the system frame capacity. Thus, depending on system implementation, it is possible to migrate from "Single stream mode" to "Multi-stream mode", providing an extended range of possibilities, such as forming a single stream, containing information from any transport stream, for further re-transmission.

The principle of "Multi-stream mode" is illustrated on Figure 9.17.

FIGURE 9.17
 “Multi-stream mode” principle

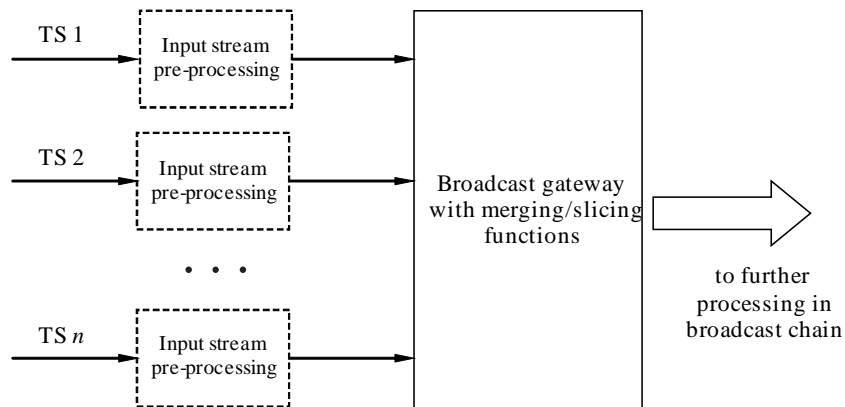

DTTB-09-17

After pre-processing, multiple input transport streams enter a broadcast gateway, where their merging is performed to create a single continuous stream with further partitioning into link layer blocks (packets, frames, etc.). In addition, scheduling in the broadcast gateway, applying a required set of parameters and performances, such as usage of dummy data blocks or padding, may be used. Thus, the channel is organized into set of separate logical pipes, each of which may provide transmission of information from separate transport streams.

The broadcast gateway is required in second generation, for example the DVB-T2 Gateway.

Migrating to DVB-T2 architecture implies the insertion of the T2 Gateway at the DTTB head-end, the update of DVB-T modulators to DVB-T2 modulators, as well as the replacement of STBs or integrated TVs with a DVB-T2 front-end. The architecture remains the same for either Single PLP or Multiple PLP (M-PLP) modes [9.71].

The T2 Gateway aims at encapsulating the incoming MPEG-2 TS into baseband frames, inserting synchronization information for SFN broadcasting, controlling modulators configuration, scheduling the M-PLP configuration as well as the TFS allocation.

The T2 modulators receive the configuration from the T2 Gateway, perform the channel encoding by adding the forward error correction information, build the T2 frames, and modulate the signal prior to transmitting it over the air. A DVB-T amplifier could be used to broadcast DVB-T2 by upgrading its DVB-T modulator to a DVB-T2 one.

The DVB-T2 standard has defined a new protocol interface the T2-MI (T2-Modulator Interface) to communicate between the T2 Gateway and the modulator(s). The T2-MI packets carry the data encapsulated into baseband frames, provide for synchronization information when broadcasting over SFN and include all the required signalling information for the transmission. All the PLP, TFS and SFN features are scheduled from the T2 Gateway and described within specific T2-MI packets [9.71] and [9.150].

There are several ways to implement of “Multi-stream mode” principle: separate TSs with common control, and one high bit-rate TS.

In the case of separate TSs with common control (see Figure 9.18), N variable-bit-rate encoders are used. Each of them is producing a constant-bit-rate TS containing one service (video, plus audio and other possible components), where the proportion of null packets varies depending on the instantaneous bit-rate. A central control unit ensures that the total amount of data (i.e. not considering null packets) does not exceed the total capacity limit.

To allow for insertion of common data into the TSs, the N TSs must have the same bit rate and should include co-timed null packets with a bit rate at least as high as that of the common data. This common data will be inserted later in the chain, replacing the co-timed null packets, and will be carried in the common PLP. The bit rate of each TS should at least be equal to the peak of the sum of the service bit rate, and the bit rate of the common data.

A re-multiplexer, which should preferably be co-sited with the encoders, then receives these TSs and replace some co-timed null packets with common data, according to the rules for splitting of TSs into data PLPs and a common PLP. The re-multiplexer would then output the N TSs to the Gateway with the required characteristics. With this method PCR values do not have to be modified anywhere in the chain. It should be noted that in a practical implementation the re-multiplexer and the gateway may be a single piece of equipment.

FIGURE 9.18

Example of separate TSs with common control

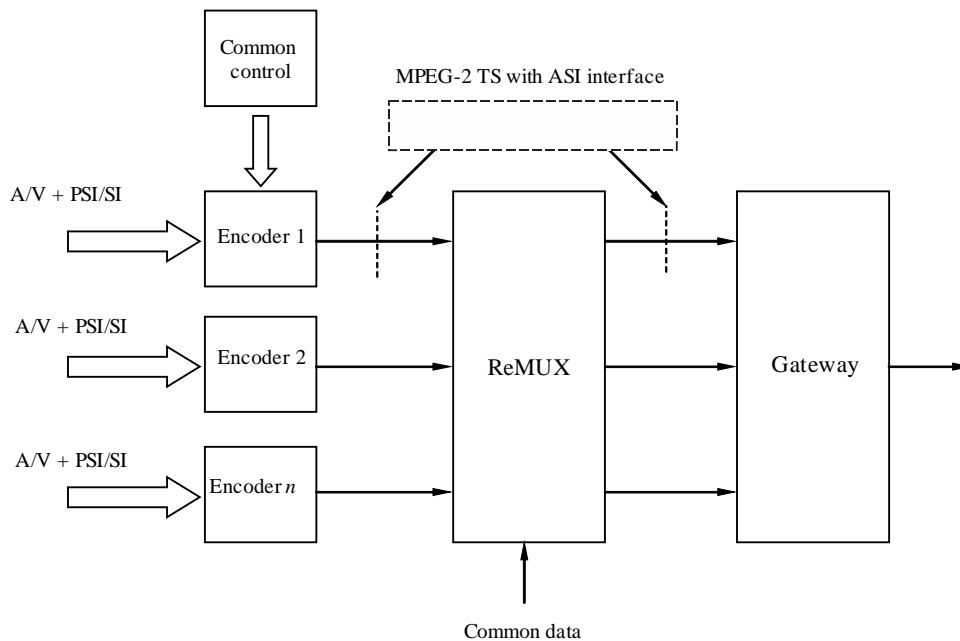

DTTB-09-18

In a case of one high bit-rate TS, a possible implementation is to use a normal statmux and then split this into the N TSs. N TSs would first be generated as above, but without the requirement for the same bit rate and co-timed common data, and then fed to a multiplexer. The multiplexer then assembles a big TS, containing all services of the elementary TSs and includes also all PSI/SI and other common data, according to splitting rules. The bit-rate of the big TS (again not considering the null packets) must not exceed the capacity limit of the N PLPs. Using traditional TS-distribution means the big TS may be transported to another site, where the splitting takes place.

The big TS is finally split into N TSs by two conceptual steps:

- 1) cloning of the big TS into N identical TSs;
- 2) for each of those TSs, keep only the packets for one PLP in the TS by replacing all other TS packets with null packets.

The result of this splitting operation is N TSs, each keeping the bit rate of the big TS, including one service and including common data co-timed with other TSs. Additionally, the PSI/SI of the original TS will have to be modified so that e.g. the single SDT (actual) of the input TS is separated into N new SDT (actual), one for each output TS. The operations performed at "the other site" may be performed using separate equipment for the multiplexer and the gateway or as a single piece of equipment.

The total complexity is lower in the first case, whereas the advantage in the second case is that conventional statmuxes may be used for generation of the single big TS.

Another possible benefit of the second arrangement is that it would allow a professional receiver to re-generate and output the original big input TS by decoding and merging all of the PLPs, because the null packets would be in complementary positions. This might be useful for re-broadcast, head-end or archiving applications.

BaseBand framing. Baseband (BB) frames are used in second generation digital television broadcasting systems as the main data containers, allowing the carriage of input stream data in MPEG-2 format (backward-compatible mode) and/or in format of continuous or packetized generic stream (GS). Where packetized streams are being carried, the packets may be mapped to BB frames either synchronously or asynchronously, i.e. each BB frame may contain a whole number of packets, or packets may be fragmented across two BB frames.

After system pre-processing the BB framing by mapping of input user packets (UP) of packetized streams directly in the frame data field (DATA FIELD) with DFL length is performed. In this case, MPEG-2 transport streams and other supported stream types may be used as input streams. In the case of continuous stream, operation of fragmentation on data blocks is performed. In the case of MPEG-2 transport stream transmission each sync byte of transport packet with user packet length (UPL) is replaced by CRC-8 checksum, that provides protection from errors at the packet level.

MPEG Media Transport (MMT). MMT transport multiplexing protocol is defined in ISO/IEC 23008-1 [9.12] and in Recommendation ITU-R BT.2074-0 [9.75]. It specifies an encapsulation format of media components, delivery protocol, and signalling information for various applications including broadcasting applications.

ISO/IEC 23008-1 has been developed to support delivery of media data over heterogeneous networks including broadcasting channels and broadband networks. In MMT-based systems, media components, such as video, audio, and closed captions (cc), constituting a TV programme are encapsulated into media fragment units (MFUs)/media processing units (MPUs). They are carried as MMT protocol (MMTP) payloads of MMTP packets and delivered in IP packets. Data applications that are related to a TV programme are also encapsulated into MFUs/MPUs, carried in MMTP packets, and delivered in IP packets.

IP packets generated like this are multiplexed over broadcasting channels with an IP multiplexing scheme, also referred to as a Layer 2 (L2) protocol, e.g. the TLV multiplexing scheme described in Recommendation ITU-R BT.1869 [9.2].

In the broadcasting channels, the three components are multiplexed into one IP data flow and delivered in one Layer 2 stream, since all transmitted information is delivered to all receiver terminals. On the other hand, in the broadband networks, components are delivered as a separate IP data flow, since each component is delivered to the receiver terminal requesting it.

In MMT-based broadcasting systems, media components delivered in different channels can easily be included in one MMT package. MMT-based broadcasting systems support hybrid delivery of multimedia content.

Therefore, MMT-based protocol enables Hybrid Broadcast- Broadband Television (HbbTV) and is also used in some application.

9.1.2 Service information in digital TV systems

In DTTB, one or more digital multiplexes may carry a number of television services, each comprised of one or more video components, one or more audio components, and optionally other components such as ancillary data. It is also necessary to transmit additional data that enables the user equipment to locate the service of interest (and the components of interest within that service), and to enable the user equipment to create a suitable navigation environment for user-friendly access to the available digital services.

To implement this in digital terrestrial broadcasting systems at program and system layer, information is inserted, which may be classified in two sub-groups: service information, specific to programs (PSI), and information being inserted at system level (SI).

The basic elements of service information are defined in Recommendation ITU-T H.222.0 [9.6] and ISO/IEC 13818-1 [9.7]. All service information is organized in tables, and contains data that may be used in the receiver for processing and synchronization in different layers: network, transport, application layer, etc.

MPEG-2 Programme-Specific Information. In the general case, according to [9.6] and [9.7], PSI consists of six tables:

- Network Information Table (NIT): defines DTTB network parameters such as carrier frequency, channel bandwidth, channel encoding parameters, etc. and references the Network PID, which carries data whose definition and structure is defined in particular digital broadcasting system.
- Program Association Table (PAT): to provide the correspondence between a program number and the packet identifier (PID) value of the TS packets that carry the program information.
- Program Map Table (PMT): to specify the types of elementary components that make up the service and the PID in the TS that carries them.
- Conditional Access Table (CAT): to support the needs of access control, the CAT associates one or more private Entitlement Management Message streams each with a unique PID value.
- Transport Stream Description Table (TSDT): to contain data that may indicate the method for including private data in the TS, or to carry descriptors whose scope includes all services carried in the TS.
- IPMP Control Information Table (ICIT): used for Intellectual Property Management and Protection (as defined in ISO/IEC 13818-11:2004 [9.76]) based on digital rights management (DRM) standards, adapted from the MPEG-4 IPMP extension specification. Implementation of ICIT transport within MPEG-2 TS is defined in [9.6] and [9.7].

MPEG-2 based Service Information. In addition to the PSI, the Service (or System) Information (SI) of digital terrestrial television systems allows for identification/selection of services or events for the user in the system TS and may also provide information on services carried by different multiplexes and even other networks. SI data complements the PSI tables specified in [9.6] and [9.7] by providing data to aid automatic tuning of receivers, and information intended for display to the user. System-specific SI is defined as follows:

- The ATSC SI is generated as specified in references [9.88-9.92]. The specification defines a Master Guide Table and Virtual Channel Table database. These tables may reference event information and extended text messages carried in other PID streams, or may include information for events present on other transport multiplexes or analogue channels.
- The DVB-T SI is specified in references [9.93-9.96]. Service information specification defines a number of tables, carried in several pre-assigned PID values. Tables include the NIT, the Service Description Table (SDT), the Event Information Table (EIT), the Time Offset Table (TOT), the Running Status Table (RST), the Time and Date Table (TDT), and the Bouquet Association Table (BAT).
- The ISDB-T SI and guidelines for its use are specified in references [9.97-9.99]. Such SI standard specifies a number of tables, carried in several pre-assigned PID values. Tables includes the NIT, the Service Description Table (SDT), the Event Information Table (EIT), the Time Offset Table (TOT), the Running Status Table (RST), the Time and Date Table (TDT), the Bouquet Association Table (BAT), the Local Event Information Table (LIT), the Event Relation Table (ERT), the Index Transmission Table (ITT), the Partial Content Announcement Table (PCAT), the Stuffing Table (ST), the Broadcaster Information Table (BIT), the Network Board Information Table (NBIT), and the Linked Description Table (LDT).

MMT service information. The MMT transport protocol uses its own type of service information and re-uses some elements of MPEG-2 SI.

There are three kinds of MMT-signalling information: Message, Table, and Descriptor. Such types of information can be common for all systems or can be system-specific.

Common type MMT messages for broadcasting systems are used for the indication of the start of MMT signalling information, Media presentation information (MPI) message, delivery of clock related information, information on required device capabilities for the content consumption and other information. The following are common type MMT-signalling information tables:

- Package access (PA) table: provides information on all other signalling tables (like PAT in MPEG-2 Systems)

- MMT presentation information (MPI) table: provides a presentation information
- MP table: provides configuration information on the MMT package, such as lists and locations of Assets
- CRI table: provides a CRI descriptor
- DCI table: Provides information on the required device capabilities for consumption of the package
- Package list table: provides the IP data flow and packet id of the PA message for the MMT package as a broadcasting service

Common type MMT-signalling information descriptors provide the relationship between the MMT timestamp and the MPEG-2 system time clock for synchronization, presentation time of MMT data block and so on.

9.1.3 Protocol stack for digital television broadcasting system

9.1.3.1 General principles

Layered models for digital broadcasting systems are defined in the Report ITU-R BT.1223 [9.13]. According to this Report, the OSI model was chosen as the baseline system model with a division of signal processing into seven layers: physical, link, network, transport, session, presentation and application layers.

At each of the layers, certain functions on the broadcast service data are performed. For each system, a protocol stack, which provides these functions, has been defined.

Each of the protocols is an interface to the adjacent layers, and defines the order and principles for the conversion of data for transfer to the upper and lower layers of the protocol stack.

Taking into account the rather different nature of digital broadcasting and traditional telecommunication systems, in digital broadcasting systems the protocol stack is being defined up to fourth layer of the OSI model. The remaining layers are not defined in the majority of system specifications and are directly defined by the applications carried by the system.

Considering that information transmission has been implemented not only for the traditional broadcasting environments, such as terrestrial, cable and satellite, but also for other telecommunication networks, such as the Internet, the protocol stack can change from between implementations.

9.1.3.2 Broadcast system layered model

Taking into account the above, and considering that in the case of interactive systems the return channel may be organized by means of any other telecommunication network, protocols up to the 4th layer of the OSI model are defined in the digital broadcasting systems themselves. Other protocols independent of the systems are also defined.

In addition, taking into account that system implementations differ to some extent, the protocol stack may be also varied. That is why a generalized protocol model of digital television broadcasting systems, without an indication of the particular implementation's protocol stack, which will be defined in section 9.2 of this Handbook, is presented below. This generalized model is based on existing Recommendations and specifications for the following applications: television and multimedia broadcasting, IP-based services and non-IP data broadcasting (see Figure 9.19).

FIGURE 9.19
Generalized protocol stack for broadcast system

Television services	Data services	Multimedia A/V services	IP-based services
Video and audio	Data and control	Video and audio	Data
MPEG-2 PES	MPEG-2 Section	IP or other signalization protocol	
MPEG-2 TS		GSE-based BB or other system stream	
Transmission layer (terrestrial television and multimedia broadcasting air interfaces, such as DVB-T, ATSC, ISDB-T FLO, T-DMB)			
Physical layer (terrestrial channel)			

DTTB-09-19

9.1.3.3 The layered model in interactive systems and new applications

Considering that nowadays broadcasting applications can be implemented in both asymmetric and symmetric ways, two types of protocol stacks need to be considered – the protocol stack of unidirectional broadcasting applications, and the protocol stack of bidirectional broadcasting applications. Each of the protocol stacks is applied to typical broadcasting systems with a broadcaster-to-user transmission channel, or for interactive services within broadcasting services with both a broadcaster-to-user and a user-to-broadcaster transmission channel.

Therefore, the concept of separation of protocols into two groups was chosen – those dependent on the network and those independent of the network.

Network-dependent protocols are located in the protocol stack up to layer 4 of the OSI model – that is, in the physical, data link, transport and network layers. Network-dependent protocols related to television and multimedia broadcasting have been developed by, *inter alia*, ATSC, ISDB, DVB etc.,. Some protocols from telecommunication networks (GSM, DECT, 3G, etc.) have been adopted for use by the interactive channel. The use of telecommunication networks for the organization of the interactive channel allows the use of the existing telecoms infrastructure and, to some extent, to reduce investments required to implement interactivity in broadcasting systems.

Network-independent protocols are located in protocol stack from the fourth layer of OSI model upwards and are not, in most cases, defined by the broadcasting system standards. Some exceptions exist in standards on middleware software (MHP, GEM, Ginga, ARIB, DASE, IMP, MHEG, etc.) which are independent of network. Application of these middleware environments is optional and defined by the market.

Network-independent protocols are defined for use in interactive applications and data delivery of any type to from the user(s). All these protocols can be classified into two types: protocols for data transmission of interactive and broadcasting services (audio, video and/or data), and protocols for data downloading/uploading and interaction organization through broadcasting or interactive channels.

The application of the network-independent protocols is not new to broadcasting systems and is not an innovation for interactive services. It is possible to consider MPEG and non-MPEG protocols at the presentation layer which define the structure and parameters of a digital stream of encoded content. An example of network-independent protocols is the possibility to use compression methods such as MPEG-2, MPEG-4/AVC/SVC, MPEG-HEVC, VC-1 within digital television and multimedia broadcasting systems.

The transfer of information other than audio and video, a network-independent protocol such as DSM-CC (Digital Storage Media – Command and Control) may be used [9.22].

Moreover, for possibility of interactive services data transmission such widespread network-independent protocols as User Datagram Protocol (UDP), the Internet Protocol (IP), Real Time Transfer Protocol (RTP), etc. may be used. More detailed information is presented in Recommendation ITU-R BT.1434 [9.14], as well as in the corresponding normative bases of current broadcasting systems.

9.1.4 Data transmission techniques over DTTB systems

9.1.4.1 General aspects

In addition to transmission of audio, video and data ancillary to the television programme (such as subtitles, teletext, so on), digital TV systems allow transmission of other types of non-broadcast service data. It became possible, primarily due to the application of new audiovisual information compression methods and other technologies allowing the bandwidth required for high quality audio and video delivery to be reduced, thus freeing some channel capacity for additional data streams. This flexibility allows the concept of using a system as a “container”, with the provision that capacity used for data cannot also be used for audio/video programme content.

The basic principles of data broadcasting are explained in Report ITU-R BT.956 [9.32], Report ITU-R BT.1210 [9.127] and Report ITU-R BT.1225 [9.128].

In general, data broadcasting within the digital television broadcasting system is based on certain principles, defined in Recommendation ITU-R BT.807 [9.15].

According to this Recommendation for providing interoperability with other telecommunication systems, data broadcasting systems' architecture should be based on the layered approach of the ISO Open Systems Interconnection (OSI) of basic reference described in ISO 7498 [9.16].

The ISO OSI basic reference model in the context of broadcasting is presented in Table 9.1.

The functional items listed at each hierarchical level do not refer to specific implementation solutions, but to the overall logical features that are considered sufficient to characterize the service and performance of any typical data broadcasting system.

Broadcasting networks remain essentially unidirectional. Even where new interactive services are introduced, the return path in most cases uses a different type of network (such as IP networks). This situation is included within the OSI 7-layer model by the concept of “connectionless” operation. In typical telecommunications, the connectionless class of transmission normally refers to a virtual unidirectional protocol, where physical bidirectional data paths exist, but are only used in one direction. However, the concept equally covers a physically unidirectional situation. In both cases, a prior agreement is required as to the purpose and significance of the data transmission. In the data broadcasting case this agreement must be set up via other means of communication, although it will frequently be implicit, such as in the purpose of equipment sold to a user.

TABLE 9.1

ISO OSI basic reference model in the broadcasting context

Layer	Principle Function	Classification
7 Application	Use of information at application level	Service information protocol
6 Presentation	Conversion and presentation of information	
5 Session	Selection of and access to information	
4 Transport	Identification of group of data	
3 Network	Identification of logical channel	Data broadcasting system
2 Data link	Linkage with logical transmission unit	
1 Physical	Physical transmission	Terrestrial broadcasting system

Mechanisms for data broadcasting within the digital broadcasting system are defined in the series of standards by ETSI, ARIB and ATSC (see Ref. [9.29, 9.30] for DVB, [9.100] for ATSC, [9.101], [9.31] for ISDB).

According to these documents, the following mechanisms are to be considered:

- Data piping;
- Data streaming;
- Encapsulation;
- Data carousel;
- Object carousels;
- Higher protocols based on asynchronous data streams.

Each of these mechanisms is optimized for certain applications and allows a certain trade-off between use of the frequency band, data delivery duration and the system overhead. Accordingly, the choice of a certain transmission mechanism is defined by the requirements of the application.

Nowadays, MPEG-2 standard series, chosen as the foundation for the DTTB system level, is the basis for definition of the data transmission mechanisms. Among them it can be possible to distinguish such standards as [9.6, 9.7] and [9.22], including the extensions for DSM-CC. During the development of both current and future digital broadcasting systems, some improvements to extend the capabilities of systems in comparison with basic system standards have been implemented.

As a base carrier for data services, the MPEG-2 transport stream and baseband stream are used, in which the required information is inserted by means of the above-mentioned mechanisms and delivered to the user through the broadcasting system. In this case, any of the elements of system and transport level may be used as required, including stuffing or adaptation fields.

Data piping. Currently, the principle of a “data pipe” is used for data broadcasting implementation in first generation digital terrestrial television and multimedia systems, and is accepted as a baseline principle in the second generation systems, where PLPs, which enable the transport of data of whatever structure with freely selectable, but PLP-specific physical parameters, are applied.

The data pipe transmission mechanism is used for data broadcasting services that require a simple, asynchronous, end-to-end delivery of data through broadcast networks.

General model of data piping provision is presented in Table 9.2.

TABLE 9.2

General model of data piping in MPEG-2 TS environment

Application
Service specific
Data piping
Transport stream MPEG-2

During transmission in an MPEG-2 TS stream by a data piping mechanism, direct insertion of data blocks is performed after fragmentation (if needed) in transport packet payload with corresponding service information for providing identification possibility and extraction of this data in the user terminal.

Data streaming. This transmission mechanism became widespread in low bit-rate applications, such as Internet video streaming, where shared video pre-processing of current data block and buffering of the following data blocks needed for video data presentation is performed. The general model of data streaming provisioning is presented in Table 9.3.

TABLE 9.3
General model of data streaming in MPEG-2 TS environment

Applications
Service specific
Data streaming
Programme elementary stream
Transport stream MPEG-2

During the data streaming, depending on application requirements, synchronous or synchronized transmission of data may or may not be needed.

Synchronous data streaming is defined as the streaming of data with timing requirements in the sense that the data and clock can be regenerated at the receiver into a synchronous data stream.

Synchronized data streaming is defined as the streaming of data with timing requirements in the sense that the data within the stream can be played back in synchronization with other kinds of data streams (e.g. audio, video).

Asynchronous data streaming is defined as the streaming of only data without any timing requirements.

It is possible to provide these requirements in the broadcasting system by synchronization methods, defined directly in the MPEG-2 System standard with embedded synchronization.

9.1.4.2 Subtitling and Closed Captions

HTML5 defines subtitles as a “transcription or translation of the dialogue ... when sound is available but not understood” by the viewer (for example, dialogue in a foreign language) and captions as a “transcription or translation of the dialogue, sound effects, relevant musical cues, and other relevant audio information ... when sound is unavailable or not clearly audible” (for example, when audio is muted or the viewer is deaf or hard of hearing). Captions are “closed” when they are not ordinarily visible and need to be selected by the viewer.

In broadcasting, the same technology can be used to deliver both subtitles and captions, so the terms are often used interchangeably.

Whatever term is used, subtitles or captions add value to the viewer in understanding the story, scene, and context in broadcast programmes whether by viewers with hearing difficulties, or by viewers for whom the programme soundtrack is in a foreign language.

The broadcasting industry has used such systems for a long time – they were widely available in analogue TV. The move to digital TV gives the possibility of delivering multiple sets of subtitles/captions: for example in multilingual countries, separate subtitles in each language could be provided. They can be used to represent not only spoken dialogue, but also other sounds important to the understanding of a programme.

There are different types of subtitles. For example, ETSI EN 300 743 [9.79] specifies the method by which they may be coded and carried in DVB transport streams. The transport of the coded graphical elements is based on the MPEG-2 system described in [9.6, 9.7].

Other formats for providing subtitles (see [9.17]) are:

- ARIB closed caption standards based on enhancements of character encoding scheme;
- SMPTE format for timed text;
- EBU format for timed text (EBU-TT);
- ARIB Timed Text Markup Language (ARIB-TTML);
- TTML Text and Image Profiles for Internet Media Subtitles and Captions 1.0 (IMSC-1);
- HbbTV subtitles.

More information on subtitles and captions is provided in Chapter 14 of this Handbook.

ETSI TS 102 823 [9.77] includes the definition of how two or more elementary streams of a particular service may be encoded so as to observe the rules of a timing model and so to ensure that they can be synchronized within the receiver. Whilst the description of this timing model focuses on video and audio, it is applicable to any kind of data stream. The existing DVB specifications for conveying ITU-R System B Teletext in DVB bit-streams and Subtitling Systems already exploit this. However, they are not readily scalable so as to be applicable to the carriage of other kinds of “auxiliary” data that needs to be synchronized.

9.1.4.3 Higher protocols based on asynchronous data streams

Using higher protocols for data broadcasting based on asynchronous data streams supports the transmission of protocols that require a stream-oriented delivery of asynchronous data through broadcast networks. The data frames of these protocols are carried in PES packets which are defined in MPEG-2 Systems.

9.1.4.3.1 Data carousel

A data carousel is used for applications that require cyclic transfer over broadcasting networks of data, which may recur periodically or may be updated from time-to-time. An example of such an application is teletext, allowing navigation over a group of information pages with the possibility of navigating to any of them.

The general data carousel model is presented in Table 9.4.

TABLE 9.4

Data carousel generalized model in MPEG-2 TS environment

Applications
Service specific
Data carousel
DSM-CC data
Section
Transport stream MPEG-2

As the basis for different data carousel implementations, the ISO/IEC 13818-6 standard, containing the main principles of DSM-CC carousel, was chosen. Implementation of the basic specification of a data carousel in different broadcasting systems has been extended to allow for the introduction of additional service information, extending of carousel element series, etc.

The elementary data block of a data carousel is the “module”, which may be transmitted as a single unit, as combined in groups or/and super-groups (Figure 9.20). To allow update, correction or replacement of information in the data carousel, separate modules may be inserted, removed or updated during operation (“on the fly”).

Each of modules is transmitted cyclically and contains download data messages, each defined using the DSM-CC specification. The number of such messages depends on the size of the module and the maximum payload of each download data message. Information describing each module and any logical grouping is provided by download control messages.

FIGURE 9.20
Data carousel principle

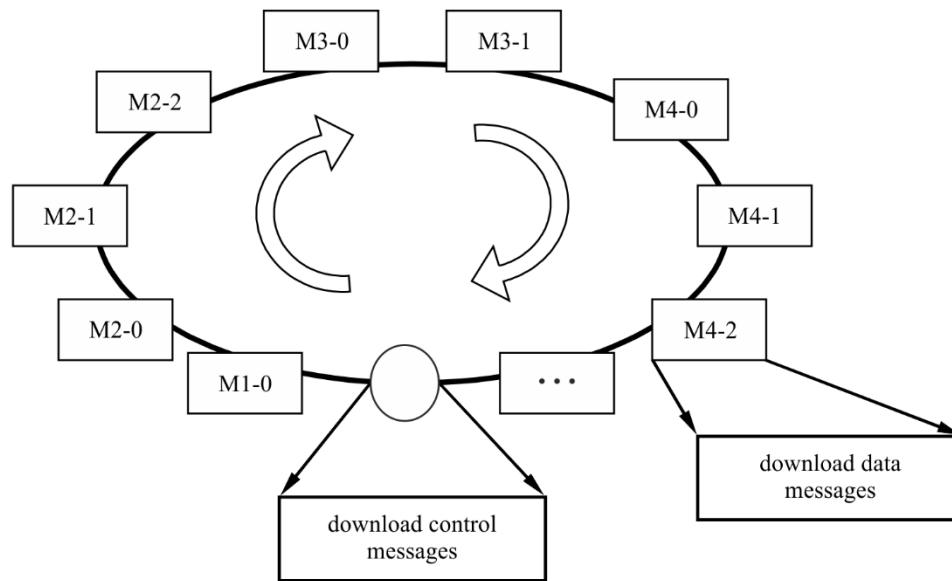

DTTB-09-20

The basic principles of teletext transmission in television systems are defined in Recommendation ITU-R BT.653 [9.18]. It provides information about the teletext systems, developed for use primarily with television systems of Recommendation ITU-R BT.470 [9.19]. The teletext service is primarily intended to display text or pictorial material in two-dimensional form reconstructed from coded data on the screens of suitably equipped television receivers.

Recommendation ITU-R BT.1301 [9.20] and ETSI EN 300 472 [9.21] specify the method by which teletext, in accordance with [9.18], may be carried in digital video broadcasting bit-streams. This transport mechanism is intended to satisfy the following requirements:

- to support, if required, the transcoding of the teletext data into the vertical blanking interval (VBI) of analogue video;
- that the transcoded signal should be compatible with existing TV receivers with teletext decoders;
- that the transmission mechanism should be capable of transmitting subtitles with accurate timing with respect to the video (i.e. to within or near the frame accuracy).

Teletext data are conveyed in PES packets which are carried by transport stream packets as defined in [9.6, 9.7]. The PID of a teletext stream associated with a service is identified in the PMT of the PSI for that service.

System software updates. Receiver software is increasingly complex. In order to guarantee the functionality of a receiver as well as increasing its functionality once deployed in the field, a software update service is required. ETSI TS 102 006 [9.78] specifies a standard mechanism for signalling a software update service and the means to carry the data for such a software update service. It is based on ISO/IEC 13818-6, ETR 162 and ETSI EN 300 468 for signalling and on ETSI EN 301 192 for data carriage. The transmission protocol is based on the DSM-CC data carousel specification (ISO/IEC 13818-6) and on the specification of DVB data carousels. Reference [9.31] is used for ISDB systems.

Multiple system software updates of multiple manufacturers are transmitted as groups in a two-layered Data Carousel. The DownloadServerInitiate message (DSI) is used as the entry point in the carousel and is shared by multiple manufacturers. One manufacturer can have multiple updates, each update in a separate group. It is assumed that all groups and modules can be transmitted on a shared elementary stream.

9.1.4.3.2 Object carousel

Object carousel is used for applications, requiring periodic broadcasting of DSM-CC User-User (U-U) Objects via broadcasting networks. In this case data broadcasting is realized according to DSM-CC Object Carousel and DSM-CC Data Carousel specification which are defined in MPEG-2 DSM-CC (see ISO/IEC 13818-6 [9.22]).

Objects may be classified according to DSM-CC specification on directory, file, stream or gateway for assess provision.

A DSM-CC object carousel facilitates the transmission of a structured group of objects from a broadcast Server to broadcast Receivers (Clients) using directory objects, file objects and stream objects. The actual directory and content (object implementations) are located at the Server. The Server repeatedly inserts the mentioned objects in the MPEG-2 Transport Stream using the object carousel protocol. The transmitted directory and file objects contain the content of the objects, while the transmitted stream objects are references to other streams during broadcasting. The stream objects may also contain information about the DSM-CC events that are broadcast within a particular stream. DSM-CC events can be broadcast with regular stream data and can be used to trigger DSM-CC applications.

9.1.4.4 Encapsulation

Encapsulation is applied in digital broadcasting systems for provision of interoperability with telecommunication systems, using other network protocols. This allows the broadcasting system to be considered not only as a traditional platform for image and sound delivery to the users, but also as platform for delivery of a wide range services, such as transmission of multimedia data and access to the Internet or other interactive applications.

Today the whole series of encapsulation implementation, mainly based on ISO/IEC 13818-6 [9.22], is defined in the broadcasting environment.

Multi-protocol encapsulation (MPE). The transmission of datagrams according to the MPE specification that is used in most cases in first generation DTTB systems is done by encapsulating the datagrams in DSM-CC sections (see [9.22]), which are compliant with the MPEG-2 private section format (see [9.6] and [9.7]).

The MPE general model is presented in Table 9.5.

TABLE 9.5

General model of MPE

Applications
Service specific
Datagram specific
MPE
DSM-CC private data
Section
Transport stream MPEG-2

During the encapsulation process, the required data is mapped into system stream with special tools, being specific to each of system stream formats. So, for example, in the case of MPEG-2, transport stream sections for data insertion are used.

MPE provides a mechanism for transporting data network protocols on top of the MPEG-2 Transport Streams. It has been optimized for carriage of IP, but can be used for transportation of any other network protocol. It covers unicast (datagrams targeted to a single receiver), multicast (datagrams targeted to a group of receivers) and broadcast (datagrams targeted to all receivers).

Due to the broadcast nature of television delivery networks, security of the data is very important. The encapsulation process allows secure transmission of data by supporting encryption of the packets and dynamically changing MAC addresses.

The multiprotocol encapsulation defines the IP/MAC Notification Table (INT). This table provides a flexible mechanism for carrying information about the location of IP/MAC streams.

Generic Stream Encapsulation (GSE). In second generation systems standard, the BB stream is chosen as system stream. This allows backward compatibility with first generation systems stream format and additionally specifies the use of a stream with variable length packets – generic stream (Figure 9.21). Thus this stream is often considered to have two types – packetized and continuous (at its core this is the same packetized stream, but with packet length more than one system frame length). In addition, a mechanism for insertion of any other data type into the stream by means of GSE encapsulation was defined ([9.9], [9.78], [9.86], [9.129]).

The GSE protocol allows for efficient encapsulation of IP and other network layer packets over a “generic” physical layer. Such a “generic” physical layer is intended as a transport mode that carries a sequence of data bits or data packets, possibly organized in frames, but with no specific timing constraints.

GSE provides a more efficient system operation for interactive systems that utilize advanced physical layer techniques such as, for instance, Adaptive Coding and Modulation (ACM). The inherent channel rate variability experienced in ACM systems makes the Generic Stream format more suited than the Transport Stream. GSE provides a flexible fragmentation and encapsulation method, which permits use of a smart scheduler to optimize system performance, either by increasing the total throughput and/or by improving the average packet end-to-end delay. In addition, GSE flexibility leads to a reduction in packet loss under fading variations, allowing the scheduler at the transmitter to dynamically change transmission parameters (for example modulation format, coding rate) for a particular network layer packet.

FIGURE 9.21

GSE encapsulation within DVB protocol stacks

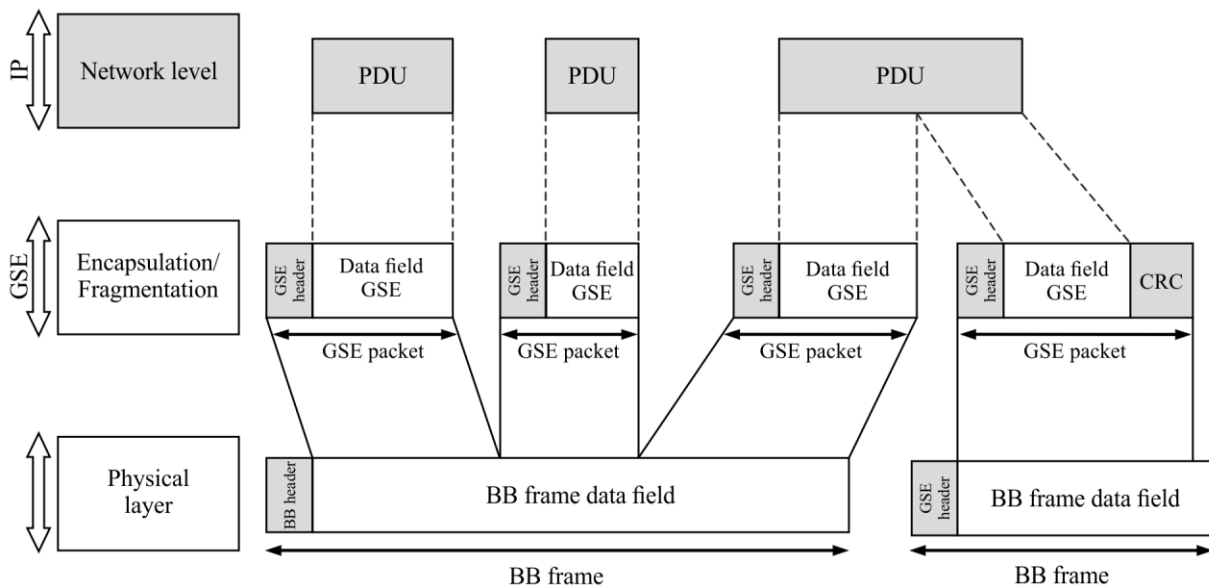

DTTB-09-21

In addition GSE encapsulation using provides following possibilities:

- Support for multi-protocol encapsulation (IPv4, IPv6, MPEG, ATM, Ethernet, 802.1pQ VLANs, etc.).
- Transparency to network layer functions, including IP encryption and IP header compression.
- Support of several addressing modes: In addition to the 6-byte MAC address (including multicast and unicast), it supports a MAC address-less mode, and an optional 3-byte address mode.

- A mechanism for fragmenting IP datagrams or other network layer packets over Base Band frames to support ACM/VCM.
- Support for hardware filtering.
- Extensibility: additional link protocols can be included through specific protocol type values (e.g. Layer 2 security, IP Header Compression, etc.).
- Low complexity.
- Low overhead.

In digital broadcasting system the possibility of simultaneous transmission of GSE and MPEG streams (mixed mode), one or several GSE ("Generic Stream only") streams is specified.

9.1.5 Data transmission over terrestrial multimedia broadcasting networks

In general, the basic mechanism for data transmission in multimedia broadcasting systems is encapsulation. Media types appropriate for content elements in multimedia broadcasting systems for mobile reception are listed in [9.102].

According to Recommendation ITU-R BT.2054 [9.23], multimedia broadcasting systems for mobile reception may have the same multiplexing and transport schemes as those for fixed reception. Broadcasting and telecommunication could be harmonized if some of the techniques used in mobile telecommunication systems are also used in multimedia broadcasting systems for mobile reception.

Multimedia signals such as audio, video or any other kind of data, are transmitted to a receiver, and then, they are presented at a proper time and in a proper way. In order to transmit and present content, the following functions are required:

Encapsulation. Multimedia signals are encapsulated into appropriate formats with timing information for presentation.

Formatting. Multimedia signals are appropriately formatted for delivery. This formatting includes the aggregation, multiplexing, and fragmentation of encapsulated multimedia signals.

Control for encapsulation, formatting and presentation. Information about the encapsulation, formatting and presentation of multimedia content is provided to the receiver.

These functions are provided by transport schemes. Transport schemes appropriate in multimedia broadcasting systems for mobile reception are listed in Table 9.6.

TABLE 9.6
Transport schemes

Scheme	Description
MPEG-2 TS (Transport Stream)	Widely used in broadcasting systems for fixed reception. It provides timing information for synchronization in packetized elementary stream (PES) layer, and a fixed-length packet for formatting.
MPEG-4 SL (Sync Layer)	Used in the synchronization layer to synchronize audiovisual content both temporally and spatially. It may be carried in MPEG-2 TS packets or real-time transport protocol (RTP) packets.
IP (see [9.24])	An intermediate protocol for media transport. It works with upper-layer protocol for media transport and may be carried in MPEG-2 TS packets.
GSE (see [9.2])	Encapsulation techniques for various kinds of packets including IP packets. A media transport protocol over IP is required.

Media transport protocols over IP that are appropriate in multimedia broadcasting systems for mobile reception are listed in Table 9.7.

TABLE 9.7

Media transport protocols over IP

Protocol	Description
RTP (real-time transport protocol)	The Internet engineering task force (IETF) protocol used for streaming services.
FLUTE (File delivery over unidirectional transport)	The IETF protocol used for the delivery of any kind of files.

Channel error characteristics differ between fixed and mobile reception because receiving conditions may change as a receiver moves around. Reliable delivery under such conditions is ensured by delivering additional data.

Schemes appropriate for ensuring reliable delivery in multimedia broadcasting systems for mobile reception are listed in Table 9.8.

TABLE 9.8

Schemes for reliable delivery

Scheme	Description
Data carousel	Data is transmitted repeatedly, so missed portions can be received during the following transmission cycle.
Application layer Forward Error Correction (AL-FEC)	A method for generating redundant data from the source data. Missed portions can be reconstructed from the redundant data by the FEC operation.

9.1.6 Transport interfaces for DTTB systems**9.1.6.1 General**

An interface is defined as a unidirectional or bidirectional connection between one or more functional equipment blocks of the same or different types. Such connections may be considered at either the physical or logical level. As interface realization is left to manufacturers, the main principles of implementation on the logical level will be further considered here.

All interfaces may be classified over following main categories:

- by application sphere: professional, semi-professional and non-professional interfaces;
- by physical transmission method: serial or parallel;
- by channel transmission method: synchronous or asynchronous.
- by directivity: unidirectional or bidirectional interfaces.

Considering that during the delivery of audiovisual information and/or data to the user, or during distribution between separate parts of broadcasting chain, different telecommunication/broadcasting or any other type of networks may be used, a set of interfaces, that may be used in different combinations in a digital television broadcasting network, have been defined.

9.1.6.2 Synchronous interfaces

For applications requiring synchronous delivery of audiovisual information, serial or parallel synchronous interfaces may be used. These interfaces are developed for compatibility with studio interfaces that allow the simplification of interaction between studio and transport functional equipment blocks. These interfaces are widely used in primary distribution or in the exchange of digital streams between studio functional blocks.

In the case of synchronous interfaces, the transport stream packet length is 188 bytes. The data transfer is synchronized to the byte clock of the data stream, which is the MPEG Transport Stream. A synchronous parallel interface is specified to cover short or medium distances, i.e. for devices placed near each other.

9.1.6.3 Asynchronous interfaces

The asynchronous transport interface has wide usage in broadcast system equipment, used for MPEG-2 transport stream delivery with a bit-rate of 270 Mbit/s.

The main principles and requirements for the physical path interface are described in standard EN 50083-9 [9.26] and ETSI TR 101 891 [9.132]. The Asynchronous Serial Interface (ASI) is a uni-directional transmission link to transfer data between professional digital video equipment.

During transmission over an asynchronous interface, two modes, optimized for different applications, may be used. In packet mode, when data is insufficient for providing of 270 Mbit/s bit-rate, a stuffing field, containing of special combination of binary symbols, are inserted between transport stream packets. In burst mode stuffing field are inserted between each byte of transport stream packet as required.

9.1.6.4 Interfaces to cable television networks

Cable distribution systems (e.g. CATV/SMATV/MATV) are sometimes used for distribution of DTTB signals. Interfaces are defined to match between the networks.

In the case then digital TV system provides interactive path, then interfaces according to Recommendation ITU-R BT.1436 [9.27] and Recommendation ITU-T J.112 [9.28] should be used. References [9.130, 9.131] are used in case Conditional Access (CA) and DVB systems.

9.1.6.5 Interfaces to telecommunication networks

Historically, use was made of ATM and PDH/SDH technologies for linking studio signals to the broadcast transmitters. Nowadays, most such connections are based on IP, either via terrestrial or satellite radio links or optical fibre links.

9.1.6.6 Interfaces to home networks

Increasingly, users share or link audio-visual information around a home network. This may be across several devices, or may enable a shared use of a single device. Taking into account the possibilities which digital TV broadcasting may provide, interaction between broadcasting and home local networks is an increasingly interesting issue.

In the past, technical solutions were often based on the IEEE 1394 standard (using ATM technology, trade name "Firewire"). Figure 9.22 depicts such a configuration in combination with various access networks.

FIGURE 9.22
General Structure of an In-Home Digital Network (example for IEEE 1394)

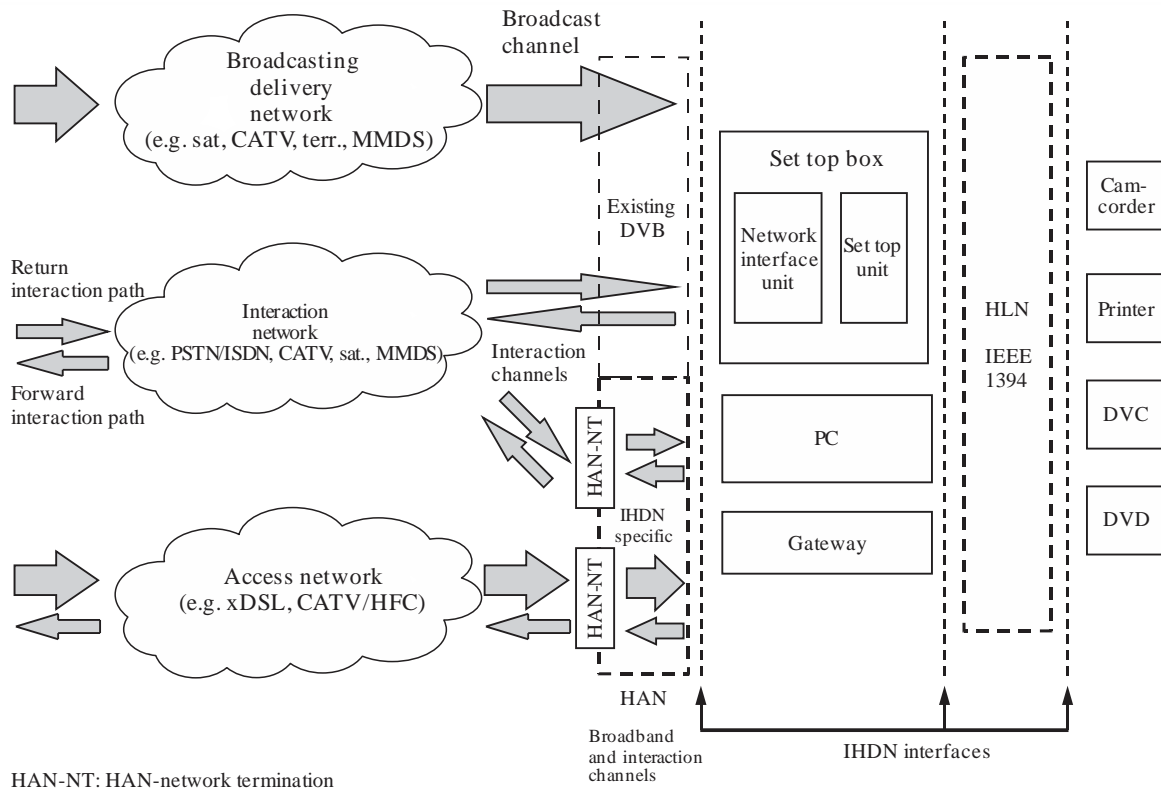

DTTB-09-22

Note that Figure 10.3 in Chapter 10 provides a similar block diagram but limited to the interactive television service, i.e. to the collaboration of the broadcasting delivery and the interaction network.

Nowadays, IP networks in the home are widespread, and therefore off-the-shelf IP solutions dominate the market. See Chapter 10 (Figure 10.2) for an example of how this may be accomplished.

Solutions based on IEEE 1394 are considered somewhat outdated. Today, home local networks are usually built up using the specifications of DLNA (Digital Living Network Alliance).²⁹

In contrast to IEEE 1394, which is mainly intended for cabled home networks and which makes use of a specific type of cable and connectors, DLNA is based on standard IP technology. The specification supports hardware and protocols for Ethernet, WLAN and MoCA (Multimedia over Cable Association [9.85]) installations. Widest use of DLNA is in combination with a home WLAN, i.e. a dedicated, managed wireless IP network. Such a network also allows for simple inclusion of a SAT-to-IP or DTTB-to-IP converter.

DLNA makes use of the UPnP (Universal Plug and Play) specifications [9.80], [9.81], [9.82], however, DLNA limits the application of UPnP to audio-visual media. An extensive description of DLNA and UPnP can be found in [9.83].

²⁹ The Digital Living Network Alliance (DLNA) is an industry initiative of more than 150 members from the IT and the entertainment sector. Main task of DLNA is the development and the maintenance of the DLNA guidelines as well as the certification of devices for standard conformity. These guidelines are available at <http://www.dlna.org/guidelines>

The setup a DLNA HLN is simple as DLNA certified CPEs (Customer Premises Equipment) care for a more or less automatic installation and interconnection. Thanks to the UPnP features, user devices can be added or removed at any time in a standardised and simple form. Consumer devices operate with an IP address obtained via DHCP or AutoIP. In order to detect consumer devices automatically, UPnP makes use of SSDP (Simple Service Discovery Protocol) functionalities [9.84]. The protocol stack of UPnP is depicted in Figure 9.23.

FIGURE 9.23
Protocol Stack for UPnP

UPnP Vendor								
UPnP Forum								
UPnP Device Architecture								
HTTP MU (multicast)	GENA	SSDP	HTTP U (unicast)	SSDP	HTTP	SOAP	GENA	
UDP					TCP			
IP								

NOTE – SOAP: Simple Object Access Protocol

GENA: General Event Notification Architecture

GENA is divided between the Publisher and the Subscriber. A Subscriber (UPnP Client) subscribes with Publisher (UPnP Server, usually the UPnP router in the home local network) in order to be informed about any change in the configuration.

9.1.7 Diversity reception of DTTB systems

Another trend is the increasing use of diversity reception in DTTB technologies. Diversity reception of DTTB signals offers substantial improvement in the coverage of television services. Frequency selective fading channel particularly effects mobile reception in terrestrial broadcasting systems, wherein the propagation characteristics change rapidly. Consequently, the fluctuation in the field strength caused by shadowing or reflection is greater in mobile reception than in fixed reception. An effective way to improve the reception performance is to use space diversity reception technology, in which multiple receiving antennas are used and the received signals are selected or combined.

Basic aspects of diversity reception tests are highlighted in Report ITU-R BT.2139 [9.74] and in sections 9.4.1 and 9.5.2. The results of tests performed in Italy and Japan with mobile reception of digital terrestrial television can also be found in [9.74]. Planning parameters for mobile reception in different DTTB standards can be found in Recommendation ITU-R BT.1368 [9.42].

9.2 Digital terrestrial television and multimedia transmission systems

Many digital terrestrial television and multimedia broadcasting systems have been proposed and standardised. Each of these has specific performance, features and possible implementations. This section provides clarification on the possible system variants to give guidance on current broadcasting systems and their implementation.

The distinction between digital terrestrial television systems and multimedia broadcasting systems is vanishing. There are three main reasons for this:

- The distinction between fixed and mobile reception is disappearing, as second-generation systems are designed for both reception modes.
- Early multimedia broadcasting systems were mostly based on IP. As later generations of DTTB receivers also have IP interfaces for connection to wireless networks, this distinction is disappearing too.

- Early multimedia receivers also had limited screen resolution, which was matched by the specific RF performance of the networks designed for them. Such distinctions between digital terrestrial television and multimedia broadcasting receivers are disappearing – even low-cost portable devices are now equipped with HD screens.

Digital broadcasting and multimedia systems standardized in the ITU-R are listed in Table 9.9. Information on each standard is provided later in this chapter and in the relevant parts of ITU-R Recommendations.

First generation Digital Terrestrial Television systems are specified in Recommendation ITU-R BT.1306 [9.33] and second generation systems are specified in Recommendation BT.1877 [9.34].

Digital Terrestrial Multimedia systems are specified in Recommendation ITU-R BT.1833 [9.35].

Spectrum shaping limits for DTTB system are defined Recommendation ITU-R BT.1206 [9.133]

Figure 9.24 shows the current status of introduction of DTTB standards across the world.

FIGURE 9.24
Status of introduction for digital television standards (September 2016)

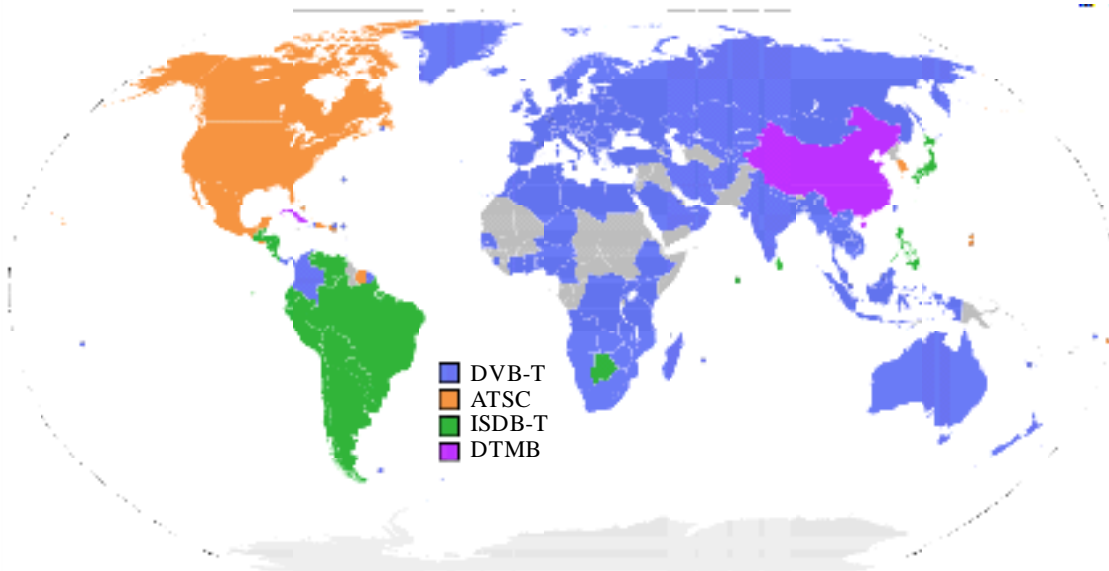

DTTB-09-24

In Figure 9.24, references to “DVB-T” include DVB-T2, and references to ISDB-T include SBTVD.

TABLE 9.9
ITU-R broadcasting standards

National / international system	ITU-R system	Handbook Section
Digital Terrestrial Television (DTT) Systems		
ATSC (Note 1)	DTT System A	9.3
DVB-T	DTT System B	9.4.1
ISDB-T	DTT System C	9.5
DTMB	DTT System D	9.6
DTMB-A	DTT System E	9.6
DVB-T2	Second generation DTT system	9.4.2

TABLE 9.9 (end)

National / international system	ITU-R system	Handbook Section
Digital Terrestrial Multimedia (DTM) Systems		
T-DMB/AT-DMB	DTM System A	9.7.8
ATSC-M/H	DTM System B	9.3
ISDB-T multimedia broadcasting for mobile reception	DTM System F	9.5.2
DVB-SH (obsolete)	DTM System I	9.4.1
DVB-H (obsolete) (Note 2)	DTM System H	9.4.1
MEDIA FLO (obsolete)	DTM System M	9.9
T2 Lite profile of DVB-T2 system (Note 2)	DTM System T2	9.4.2

NOTE 1 – The original variant of ATSC is now called ATSC 1.0. A further development of ATSC for non-real time delivery of services is called ATSC 2.0; see Section 9.3.2. A future broadcasting standard, called ATSC 3.0, is described in Section 9.3.3.

NOTE 2 – Studies on development of next generation DVB-H standard (DVB-NGH) were started and as result of this the draft technical specification ETSI EN 303 105 is published (DVB BlueBook A160, November 2012) [9.73]. DVB-NGH standard uses practically the same technologies as in DVB-T2 Lite, which is intended to extend DVB-T2 performance to handheld reception. The next stable draft of ETSI standard on this system is expected in October 2016.

9.3 ATSC

The ATSC (Advanced Television Systems Committee) standards describe a system designed to transmit high quality video and audio and ancillary data over a single 6 MHz channel. The original ATSC system (also called ATSC 1.0) can deliver the MPEG-2 Transport Stream with 19.39 Mbit/s of throughput in a 6 MHz terrestrial broadcasting channel (ITU-R Digital Terrestrial Television System A). Although the ATSC transmission subsystems are designed specifically for terrestrial and cable applications, the objective is that the video, audio, and service multiplex/transport subsystems can be useful in other applications. For delivery of DTV content to mobile or portable devices, ATSC uses the Mobile/Handheld (M/H) extension that is also called ATSC M/H (ITU-R Digital Terrestrial Multimedia System B).

A further extension to the ATSC standard (called ATSC 2.0) provides for “Non- Real-Time” (NRT) delivery of file-based content, including programs and clips to both fixed location and mobile DTV receivers. ATSC 2.0 also provides Interactive Services allowing broadcasters to connect broadcast programming with additional services related to that programming.

Currently, the Advanced Television Systems Committee is working on a next-generation ATSC system specification, entitled ATSC 3.0. This system will use COFDM for improved mobile reception and the multiplex will be IP based (like streaming services) rather than using the MPEG Transport Stream. At the time of writing of this Handbook, the full specification was not been completed. Consequently, ATSC 3.0 is not yet included in an ITU Recommendation. ATSC standards that have been finalised and approved by ATSC can be found on the ATSC website, www.atsc.org. A summary of expected ATSC 3.0 performance is given in Section 9.3.3.

9.3.1 ATSC 1.0

9.3.1.1 ATSC 1.0 architectural model

The ATSC broadcast system includes standards for the Main service ([9.48]-[9.53]) and a Mobile/Handheld (M/H) extension ([9.54]-[9.63]). A block diagram for the ATSC 1.0 system is shown in Figure 9.25. The ATSC digital television system consists of three subsystems.

- Source coding and compression;

- Service multiplex and transport;
- RF transmission.

FIGURE 9.25
ATSC broadcast system with TS Main and M/H services

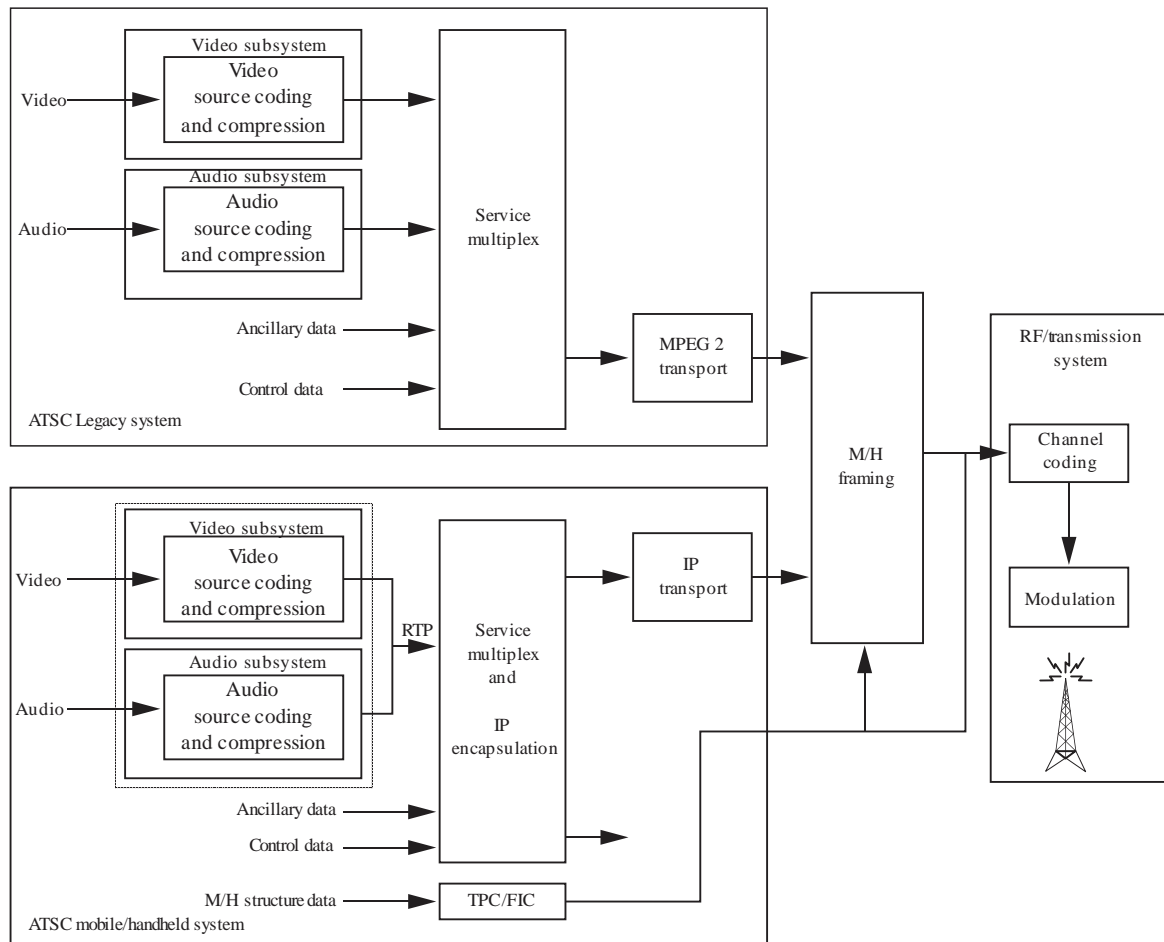

DTTB-09-25

The ATSC M/H service shares the same RF channel as a standard ATSC broadcast service described in ATSC A/53, also known as the “Main service” (or more precisely TS-M). M/H is enabled by using a portion of or the total of the available bit rate capacity of 19.39 Mbit/s and utilizing delivery over IP transport.

Central to the M/H extension are additions to the physical layer of the ATSC transmission system that are easily decodable under high Doppler rate conditions. Additional training sequences and additional forward error correction (FEC) assist reception of the enhanced stream(s).

9.3.1.2 Key technologies of ATSC 1.0

Key technologies used in ATSC 1.0 are the following:

Main ATSC service

- **System stream format:** modified MPEG-2 transport stream with possibility of delivery of information of traditional television applications (subtitles, teletext, electronic programme guide, etc.) and such applications as additional information on TV programs (possibly from Internet), interactive applications, etc.;

- **FEC algorithms:** concatenated RS (207, 187, 10) block code and 4-state convolutional encoder/differential encoder with code rate 2/3 as part of twelve trellis encoders. Also concatenated $R = 1/2$ or $R = 1/4$ trellis;
- **Interleaving:** interleaving is provided to a interleaving depth of approximately 4 ms. The interleaver employed is a convolutional byte interleaver with an interleaving degree $B = 52$ and an increment in the number of bytes per row $M = 4$;
- **8-VSB modulation:** The 8-level symbols combined with sync signals are used to suppressed-carrier modulate a single carrier. The lower sideband is removed except for a small transition region. A linear-phase, root-raised cosine Nyquist filter response is employed for spectral shaping in the transmitter. The VSB modulator uses the 10.76 M symbols/s, 8-level trellis encoded composite data signal (with pilot and sync added). Nominally, the roll-off in the transmitter has the response of a linear-phase root-raised cosine filter with α (roll-off factor) equal to 0.1152;
- **Channel compensation and synchronization:** a small pilot at the suppressed-carrier frequency (nominally 309 kHz from the lower band edge) and in-phase with the suppressed carrier is added to the signal;
- **Channel bandwidth:** ATSC uses a 6 MHz channel bandwidth;
- **Single frequency networks (SFN):** it is possible to implement an SFN mode with frame synchronization defined by ATSC standard [9.64] with some additional requirements to ATSC receiver equalizers.

ATSC M/H extension

- **Source encoding:** MPEG-4 AVC/ SVC coding (ITU-T Rec. H.264 | ISO/IEC 14496-10) for video and MPEG-4 HE-AAC v2 (ISO/IEC 14496-3 with Amendment 2) for audio in stereo/mono modes;
- **Service/ content protection:** the ATSC-M/H Service Protection system is based on the OMA BCAST DRM Profile. In the OMA BCAST DRM Profile there are two modes for Service Protection: 1) interactive and 2) broadcast-only. In the interactive mode, the receiver supports an interaction channel to communicate with a service provider in order to receive Service and/or Content Protection rights. In the broadcast-only mode, the receiver does not use an interaction channel to communicate with a service provider. Requests are made by the user through some out-of-band mechanism to the service provider, such as calling a service provider phone number or accessing the service provider website;
- **Improved FEC sub-system:** for robust reception on mobile/ handheld devices additional RS/CRC encoding is used. Concatenation of an additional convolutional encoder with TCM encoders provides a turbo code that is corresponding to a Serial Concatenated Convolutional Code (SCCC). Additional robustness is provided in time-varying wireless channels using a symbol interleaver. For the signalling channel a Parallel Concatenated Convolutional Code (PCCC) with code rate 1/4 is used for protection;
- **Improved channel compensation:** the M/H transmission system inserts long and regularly spaced training sequences providing the greatest benefit for a given number of training symbols in high-Doppler rate conditions. The length of the training sequences provides fast acquisition of the channel during burst power-saving operation of the demodulator;
- **Advanced signalling channel:** the data organization of the M/H system is established by information in the M/H Signalling Channel. Two channels (Transmission Parameter Channel (TPC) and Fast Information Channel (FIC)) for signalling are used. The FIC channel carries cross-layer information to enable a fast M/H service acquisition. The TPC channel defines information about recovering required data from M/H Frame.

9.3.1.3 Physical and link layers of ATSC 1.0

The functional block diagram for processing the Main ATSC service path is presented in Figure 9.26.

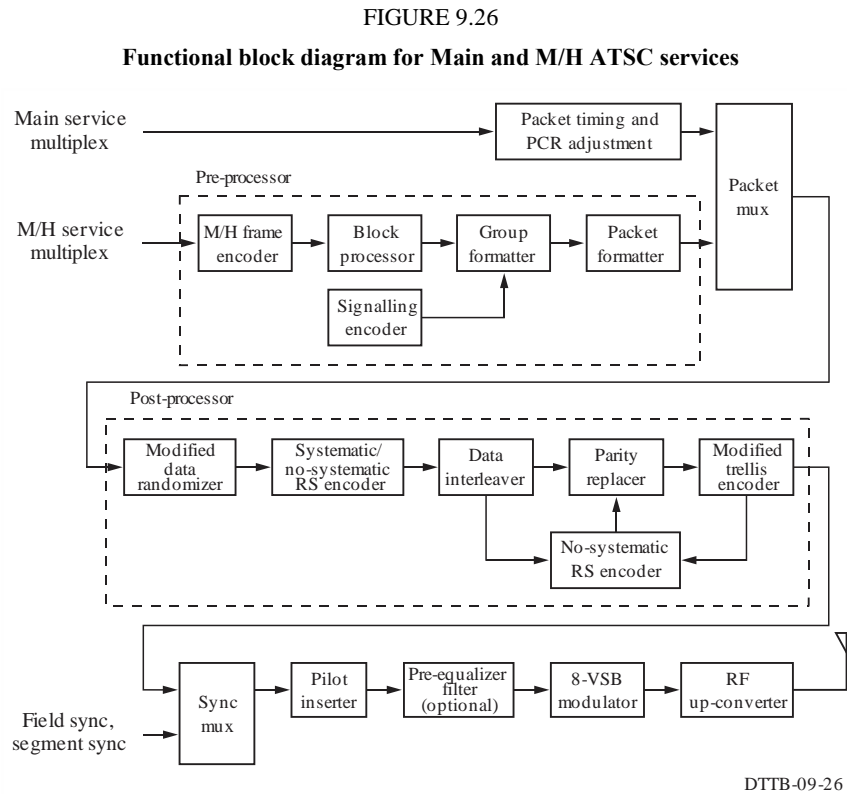

The incoming data in the Main Service channel is randomized and then encoded using Reed-Solomon coding for forward error correction (FEC), one-sixth-Data-Field interleaving and two-thirds-rate trellis coded modulation. The randomization and FEC processes are not applied to the sync bytes of the transport packets, which are represented in transmission by Data Segment Sync signals. Following randomization and forward error correction processing, the data packets are formatted into Data Frames for transmission, and Data Segment Sync and Data Field Sync are added. The signal is modulated and a small pilot carrier is inserted prior to RF up-conversion.

The M/H extension to the transmission system receives two sets of input streams: one consists of the MPEG transport stream (TS) packets of the main service data, and the other consists of the M/H service data. At a high level, the function of the M/H transmission system is to combine these two types of streams into one stream of MPEG TS packets and process and modulate them into the normal ATSC trellis-coded 8-VSB signal.

The ATSC-M/H system is separated into logical functional units corresponding to the protocol stack illustrated in Figure 9.27. The system uses IP-based multimedia transmission for enabling AVC/ HE-AAC video and audio services and personalized delivery of content. The IP-protocol requires UDP/ RTP protocol stack for video services and ALC control for FLUTE/ Service Guide.

FIGURE 9.27
ATSC-M/H system protocol stack

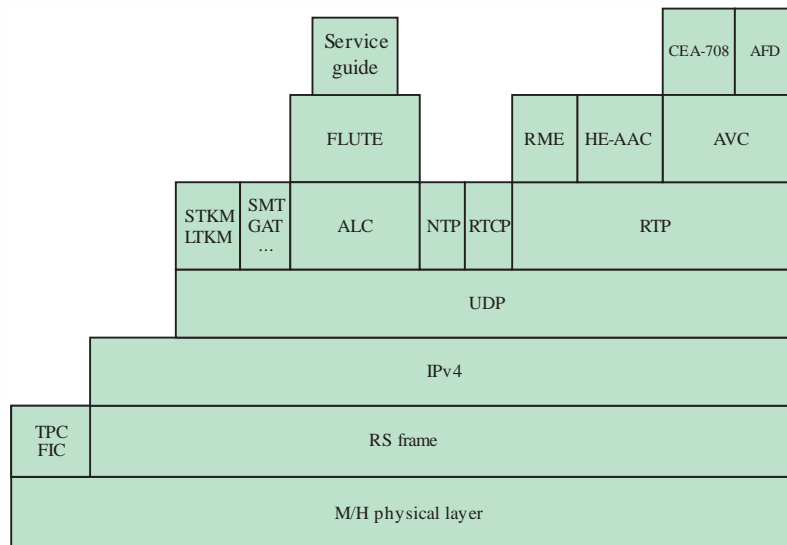

DTTB-09-27

The M/H data on the link layer is partitioned into Ensembles, each of which contains one or more services. Each Ensemble may be coded to a different level of error protection depending on the application. M/H encoding includes FEC at both the packet and trellis levels, plus the insertion of long and regularly spaced training sequences into the M/H data. Robust and reliable control data is also inserted for use by M/H receivers. The M/H system provides burst transmission of the M/H data, which allows the M/H receiver to cycle power in the tuner and demodulator for energy saving.

The M/H data are transmitted within the 8-VSB signal on a time-slice basis, which facilitates burst mode reception of just selected portions of the M/H data by an M/H receiver. Each M/H Frame time interval is divided into five sub-intervals of equal length, called M/H Subframes. Each M/H Subframe is in turn divided into four sub-divisions of length 48.4 ms, the time it takes to transmit one VSB frame. These VSB frame time intervals are in turn divided into four M/H Slots each (for a total of 16 M/H Slots in each M/H Subframe).

For compatibility with legacy 8-VSB receivers, the M/H service data is encapsulated in special MPEG-2 transport stream packets, designated as M/H Encapsulation (MHE) packets. The M/H transmission system can accommodate encapsulated service data that is in any desired format. For example, services carried in MPEG transport streams such as MPEG-2 video/ audio, MPEG-4 video/audio, other data, or services carried by IP packets.

Time-division multiplexing of main and M/H data introduces changes to the time of emission of the main service stream packets compared to the timing that would occur with no M/H stream present. Changes are necessary to compensate completely for temporal displacements at the combining point so that the emitted signal complies with the MPEG and ATSC standards to protect legacy receivers. These functions are performed by the "Packet Timing & PCR Adjustment" block shown in Figure 9.26.

The operations of the M/H transmission system on the M/H data are divided into two stages: a pre-processor and a post-processor.

The function of the pre-processor is to rearrange the M/H service data into an M/H data structure, to enhance the robustness of the M/H service data by additional FEC processes, to insert training sequences, and subsequently to encapsulate the processed enhanced data into MHE transport stream packets. The pre-processor operations include M/H Frame encoding, Block processing, Group formatting, packet formatting, and M/H signalling encoding.

The function of the post-processor is to process the main service data by normal 8-VSB encoding and to manipulate the pre-processed M/H service data in the combined stream to ensure compatibility with ATSC 8-VSB receivers. Main service data in the combined stream is processed exactly the same way as for normal 8-VSB transmission: randomizing, RS encoding, interleaving, and trellis encoding. The M/H service data in the combined stream is processed differently from the main service data in that the pre-processed M/H service data bypasses the data randomizer.

The pre-processed M/H service data is processed by a non-systematic RS encoder. Additional operations are done on the pre-processed M/H service data to initialize the trellis encoder memories at the start of each training sequence, which has been included in the pre-processed M/H service data. The non-systematic RS encoding allows the insertion of the regularly spaced long training sequences without disrupting reception by legacy receivers.

The Fast Information Channel (FIC) that is a separate channel from the data channel is delivered through the RS Frames. The main purpose of the FIC is to efficiently deliver essential information for rapid M/H Service acquisition. This information primarily includes binding information between M/H Services and the M/H Ensembles carrying them, plus version information for the M/H Service Signalling Channel of each M/H Ensemble.

9.3.1.4 Performance of ATSC 1.0

The Carrier-to-noise (C/N) ratio in an additive white Gaussian noise (AWGN) channel is 15.19 dB for 2/3 trellis coding. Also the C/N ratios are 9.2 dB for 1/2 rate concatenated trellis coding and 6.2 dB for 1/4 rate concatenated trellis coding. More information about ATSC receiver performance is provided in the ATSC Recommended Practice A/74 [9.65].

C/N requirements for ATSC-M/H are highlighted in ATSC Recommended Practice A/174 [9.66] on mobile receiver performance. Additionally, maximum sensitivity called Total Isotropic Sensitivity (TIS) is estimated below. Such requirements are provided in Table 9.10 and Table 9.11 for devices with in-build antennas.

TABLE 9.10

Typical TIS for UHF Devices with Self Contained Antenna Systems

Device class	Implementation margin	Noise figure	Antenna efficiency	AWGN C/N for rate 1/4	TIS at 584 MHz
Mobile Handheld	3 dB	6 dB	-8.6 dB	3 dB	46.5 dB μ V/m
Personal Player	3 dB	6 dB	-5.6 dB	3 dB	43.5 dB μ V/m

TABLE 9.11

Typical TIS for VHF Devices with Self Contained Antenna Systems

Device class	Implementation margin	Noise figure	Antenna efficiency	AWGN C/N for rate 1/4	TIS at 584 MHz
Mobile Handheld	3 dB	6 dB	-25 dB	3 dB	53.4 dB μ V/m
Personal Player	3 dB	6 dB	-22 dB	3 dB	50.4 dB μ V/m

9.3.1.5 Summary of ATSC 1.0 system parameters

Table 9.12 summarises the characteristics of the ATSC 1.0 system (also see Report ITU-R BT.2295-1 [9.43]).

TABLE 9.12

Key characteristics of ATSC system

Characteristics	ATSC
Reception modes: – Fixed – Portable – Portable handheld – Mobile	+ + + +
Channel bandwidth	a) 6 MHz; b) 7 MHz; c) 8 MHz
Net data rates	Depending on modulation and code rate: a) 4.23-19.39 Mbit/s b) 4.72-21.62 Mbit/s c) 5.99-27.48 Mbit/s
Spectrum efficiency (bit/s/Hz)	0.55-1.48
Single frequency networks	
Broadcasting types: – sound – multimedia – TV	+ +
Transmission data/service types	Video, audio, data
Frequency bands	VHF, UHF
Used bandwidth	At –3 dB: a) 5.38 MHz; b) 6.00 MHz; c) 7.00 MHz
Number of segments	1
Number of subcarriers per segment	1
Subcarrier spacing	–
Active symbol duration	a) 92.9 ns; b) 83.3 ns; c) 71.4 ns
Guard interval duration/ ratio	–
Frame duration	a) 48.4 ms; b) 43.4 ms; a) 37.2 ms
Time/ frequency synchronization	Segment sync, pilot carrier; Frame sync
Modulation methods	8-VSB
Inner FEC	2/3 trellis, concatenated 1/2 or 1/4 trellis
Inner interleaving	Independently encoded streams interleaved in time: a) 12; b) 24; c) 28
Outer FEC	RS (207,187, T = 10), concatenated RS (184,164, T = 10)
Outer interleaving	52 segment convolutional byte interleaved, concatenated 46 segment byte interleaved
Data randomization/ energy dispersal	16 bit PRBS
Hierarchical transmission	–
Transmission parameter signalling	Mode symbols in frame sync

9.3.1.6 Link budgets for ATSC 1.0

Recommendation ITU-R BT.1368 [9.42] provides link budgets in terms minimum field strengths for ATSC 1.0 terrestrial digital television (Main service) as shown in Table 9.13 below.

TABLE 9.13
Derivation by the figure of merit method ATSC 6 MHz system

Planning parameter ⁽¹⁾	Low VHF 54-88 MHz	High VHF 174-216 MHz	UHF 470-806 MHz
Frequency (MHz)	69	194	615
C/N (dB)	19.5 ⁽²⁾	19.5 ⁽²⁾	19.5 ⁽²⁾
k (dB)	-228.6	-228.6	-228.6
B (dB(Hz)) (6 MHz)	67.8	67.8	67.8
G_{1m^2} (dB)	-1.8	7.3	17.2
G_D (dB)	6	8	10
G_I (dB)	8.2	10.2	12.2
Transmission line loss (dB) α_{line}	1.1	1.9	3.3
Antenna 300/75 balun loss (dB) α_{balun}	0.5	0.5	0.5
Receiver noise figure (dB)	5	5	10
T_{rx} (K)	627.1	627.1	2 610
T_{line} (K)	65.0	102.9	154.4
LNA noise figure (dB)	5	5	5
LNA gain (dB)	20	20	20
T_{LNA} (dB)	627.1	627.1	627.1
T_{balun} (K)	31.6	31.6	31.6
T_a (K)	9 972.1	569.1	Negligible
$T_a\alpha_{balun}$ (K)	8 885.1	507.1	Negligible
$T_{line}/\alpha G$ (K)	0.8	1.6	3.3
$T_{rx}/\alpha G$ (K)	8.1	9.7	55.8
T_e (K)	9 552.6	1 176.8	717.8
10 log(T_e)(dB(K))	39.8	30.7	28.6
G_A (dB)	7.7	9.7	11.7
E_{rx} (dB(μ V/m)) ^{(2), (3)} (TBC)	35	33	39

NOTES – The values in the Table were calculated assuming C/N with typical multipath reception impairment and equal partitioning for noise and interference. The receiving system model is a typical receiving installation located near the edge of coverage and consists of an externally mounted antenna, a low noise amplifier (LNA) mounted at the antenna, an interconnecting downlead cable and an ATSC receiver.

⁽¹⁾ For definitions see Attachment 1 to Annex 1 in Recommendation ITU-R BT.1368 [9.42].

⁽²⁾ Figures should be adjusted downward (towards better performance) by 6 dB for 1/2 rate concatenated trellis coding or 9 dB for 1/4 rate concatenated trellis coding.

⁽³⁾ For formula see Attachment 1 to Annex 1 in Recommendation ITU-R BT.1368 [9.42].

An example estimation of ATSC M/H link budget for an Outside Mobile (vehicular) receiver (using Antenna Gain) and build-in antenna devices are summarized in Table 9.14.

TABLE 9.14

Example of link budget for devices with outside Vehicular Antennas

Item	Personal Handheld 584 MHz	Personal Handheld 195 MHz
System Reference Temperature, K	298.0	298.0
System Reference Temperature Noise Power, dBm	-106.5	-106.5
Device Noise Temperature (6 dB NF), K	1192.0	1192.0
Implementation Loss (self-radiation) (0 dB), K	0.0	0.0
Environmental Noise Temperature, K	372.5	2384.0
Total System Input Noise Temperature, K	1564.5	3576.0
Effective Input Noise Power, dBm	-99.3	-95.7
C/N for Mixed Rate and a TU-6 test ensemble, dB	17.0	17.0
Required Receiver Input Power, dBm	-82.3	-78.7
Antenna Gain, dBi	0.0	-3.0
Operational Field Strength, dB μ V/m	50.2	47.3
System Reference Temperature, K	298.0	298.0
System Reference Temperature Noise Power, dBm	-106.5	-106.5
Device Noise Temperature (6 dB NF), K	1192.0	1192.0
Implementation Loss (self-radiation) (3 dB), K	1192.0	1192.0
Environmental Noise Temperature, K	372.5	2384.0
Total System Input Noise Temperature, K	2756.5	4768.0
Effective Input Noise Power, dBm	-96.9	-94.5
C/N for Mixed Rate and a TU-6 test ensemble, dB	17.0	17.0
Required Receiver Input Power, dBm	-79.9	-77.5
Antenna Gain, dBi	-8.6	-25.0
Operational Field Strength, dB μ V/m	61.3	80.0

9.3.2 ATSC 2.0

ATSC 2.0 is designed to take the TV experience on fixed receivers to the next level by introducing a number of enhanced features based on newly-developed standards and focused application of existing standards.

At the physical layer ATSC 2.0 is backward compatible with ATSC 1.0. Mainly new features are introduced on the top-level of this DTTB system.

Internet-connected consumer devices enable new distribution and consumption models for television entertainment programming and information.

Many consumer electronics products such as video game consoles, Blu-ray™ disc players, and personal computers can be connected to the Internet, allowing them to receive content and services from Internet-based service providers. Televisions can also be connected to the Internet.

Other more fundamental developments in video technology, incorporated in ATSC 2.0, significantly improve the operation of TV systems. Since the first widely-deployed video compression technology, MPEG-2, was introduced decades ago, the AVC (H.264) video codec is now widely used for high-quality high-efficiency video distribution; it is found in Internet streaming services and also in the ATSC Mobile DTV standard. New high efficiency audio codecs are also found in the most modern video services.

ATSC 2.0 is designed to be in-band backward compatible, which means that, although ATSC 2.0 services are not expected to run on current ATSC receivers, the inclusion of ATSC 2.0 services in a transmission are designed to be compatible with current ATSC receivers' ability to receive current ATSC services in that transmission. ATSC A/107 [9.67] provides a top-level specification of the ATSC 2.0 fixed-broadcast digital television services, which augment the digital television services defined in ATSC Standards A/53 [9.48] to [9.53].

9.3.2.1 Non Real-Time Services

The ATSC A/103 non real-time (NRT) standard [9.68] describes standardized signalling, announcement, and transport of NRT essence. Non-Real-Time services for fixed broadcast are delivered within IP subnets; the particular IP subnets associated with a given virtual channel are identified by references in the Terrestrial Virtual Channel Table (TVCT) and associated PAT/PMT tables. There are seven consumption models identified by the NRT standard.

9.3.2.2 Interactive Services

The ATSC A/105 Interactive Services Standard [9.69] allows broadcasters to connect broadcast programming with additional services related to that programming. Central to this system are Declarative Objects (DOs) providing the user's interactive experience. Changes to the life-cycle state of Declarative Objects (for example to launch or kill a DO) can be initiated and changed by both broadcasters and viewers. The system provides for the extension of these services to second screens and provides for delivery of needed resources via the Internet path.

In addition to services already part of traditional terrestrial broadcast television, services described in the Interactive Services standard include:

- Personalization
- Service usage reporting
- Receiver access to web-based servers
- Support for automatic content recognition.

Three contexts for interactivity are supported in the Interactive Services Standard and related ATSC standards:

- Triggered interactive adjunct data services
- Other interactive NRT services
- Interactive applications not bound to a service.

In each case the interactivity is provided by Declarative Objects (DOs) that conform to the specifications of the Interactive Services Standard.

9.3.3 ATSC 3.0

At the time of writing this Handbook, ATSC 3.0 system standardization is still underway. However, according to ITU-R materials, ATSC 3.0 is expected to provide the following services [9.70]:

- High-definition television;
- Multicasting for multimedia;
- 5.1 digital surround sound;
- Electronic program guides;
- Enhanced closed captioning;
- Backwards compatible enhancements.

The ATSC 3.0 physical layer requirements are as follows [9.70]:

- Flexible, robust transmission system;
- Greater capacity (more bits/Hz);
- Ability to trade-off capacity for robustness;

- Robust system discovery and signaling;
- Integrated mobile/handheld capabilities;
- Flexible bit-rate and coverage area choices;
- Enable on-channel repeaters for robust indoor and mobile reception;
- Channel bonding enables spectrum sharing;
- Return channel option for emerging markets;
- Spectrum efficiency.

The expected physical layer features are as follows [9.70]:

- FFT sizes of 8K, 16K and 32K;
- Time-division multiplexing option;
- Physical Layer Pipe concept is same, Multiple PLP is a likely use case;
- Hierarchical preambles preceding frames;
- Low Density Parity Check for Forward Error Correction is similar, but there are new codes with different code rates;
- Bootstrap signal has 10 dB C/N robust performance for synchronization and tracking of system types;
- Non Uniform Constellations provide more than 1 dB performance gain;
- Higher modulation order options (up to 4096-QAM);
- Layered Division Multiplexing addresses robust service area;
- Wider range of SNR operating points (–6 dB to over 30 dB);
- 4 PLPs per service assignment for graceful operation (robust audio, scalable video coding options);
- Channel bonding enables spectrum sharing.

Expected management and protocols are as follows [9.70]:

- Management and protocols layer;
- Service delivery and synchronization;
- Service announcement and personalization;
- Interactive services and companion screens;
- Redistribution support / watermarks;
- IP transport (only) will be used for broadcast delivery of both streaming and file content;
- Broadcasting is part of the Internet.

Expected ATSC 3.0 video performance [9.70]:

- UHD TV is a key goal of ATSC 3.0 – 4k is the current focus, with 8k possible in the future;
- Resolution of 3840×2160;
- Frame rate of 60 Hz (120 Hz is under consideration);
- High dynamic range;
- Wide color gamut (as per Recommendation ITU-R BT.2020);
- 10 bits/pixel;
- HDTV delivery to mobile and handheld devices such as tablets.

The ATSC 3.0 video system will take advantage of recent advances in coding technologies:

- MPEG HEVC (Scalable video coding is being carefully studied);
- Attractive for possible efficiency gains;
- System complexity may be an issue;
- A promising system for delivery to multiple platforms;

- HEVC with scalable extensions (aka SHVC): 2x spatial scalability between base layer (BL) and enhancement layer (EL); Base layer optimized for mobile reception; Enhancement layer optimized for UHD resolution.

ATSC 3.0 audio performance [9.70]:

- Immersive audio features will provide high spatial resolution in sound source localization;
- Azimuth, elevation, distance (Increased sound envelopment for an enhanced “suspension of disbelief”);
- ATSC 3.0 audio targeted to various devices – Fixed, mobile & handheld;
- Differing speaker set-ups, and headphones, Including sub-optimal set-ups;
- ATSC 3.0 audio will provide for selectable, mixable audio components;
- Control of dialog: hearing- impaired can raise dialog level;
- Alternate audio tracks: Multiple language tracks, special commentary, and music and effects tracks;
- Allows viewers to select elements of the program mix and adjust to their preferences.

9.4 DVB-T and DVB-T2

According to ETSI EN 300 744 [9.36] and ETSI EN 302 755 [9.8] the DVB-T/DVB-T2 systems are defined as the functional blocks which perform the adaptation of baseband TV signals from the output of the transport multiplexer, to the terrestrial channel characteristics. For transmission of television broadcasting signals, channel bandwidths of 1.7 MHz and 7 MHz and used in the frequency band 174-230 MHz, and 8 MHz channel bandwidth are used in the band 470-862 MHz.

Additionally, DVB-T and DVB-T2 systems are effective mean for digital signal delivery in multipath condition and can thus be used for other applications such as electronic news gathering or microwave distribution system (see ETSI EN 301 701 [9.37] for DVB-T). Chapter 15 covers the use of DVB systems in ENG applications.

Due to the universally-supported input formats for transmitted information, high flexibility in selection of parameters to give the trade-off between channel capacity and receiver input signal power, the possibility of robust functioning in different broadcasting network types (multi-frequency or single-frequency networks) and receiving conditions (fixed, portable or mobile reception), DVB-T and DVB-T2 systems are used as the main standards for digital terrestrial television broadcasting in many countries (see map in Figure 9.24). More detailed information on introduction status of these standards is presented on the DVB Project website (www.dvb.org).

Some statistics on DVB-T and DVB-T2 systems adoption, provided by the DVB Project, are illustrated in Figures 9.28 to 9.30.

An analysis of the number of countries using DVB-T or -T2 systems are provided in Figure 9.28 grouped as follows:

- Countries with DVB-T introduction in progress or complete;
- Countries with DVB-T2 introduction in progress or complete;
- Countries with both DVB-T and DVB-T2 introduction in progress or complete.

FIGURE 9.28
Introduction of DVB-T and DVB-T2 systems (September 2016)

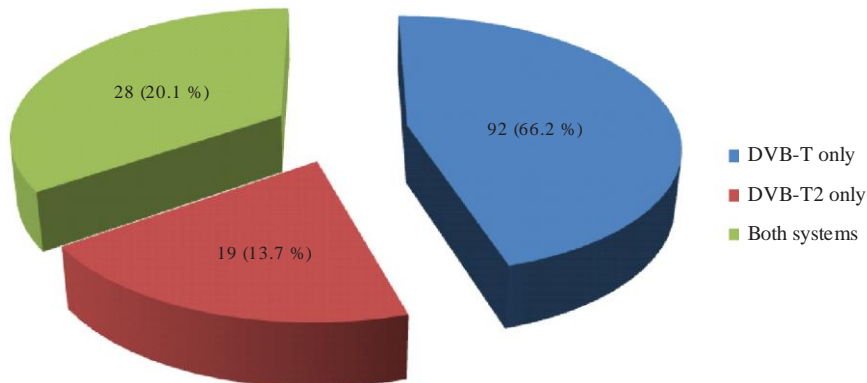

DTTB-09-28

Analysis shows that in August 2015 of the 139 countries where DVB was chosen, in 92 countries (66.2%) only DVB-T broadcasting networks were in use or being introduced, in 19 countries (13.7%) DVB-T2 only was being used or introduced and in 28 countries (20.1%) both standards were in use or being introduced.

As of September 2016, statistics for 150 countries are available. DVB-T only is used in 66 countries (44%), DVB-T2 only is used in 30 countries and both systems are used in 54 countries.

Figures 9.29 and 9.30 show the status of introduction of both standards (DVB-T & DVB-T2).

FIGURE 9.29
Introduction of DVB-T standard

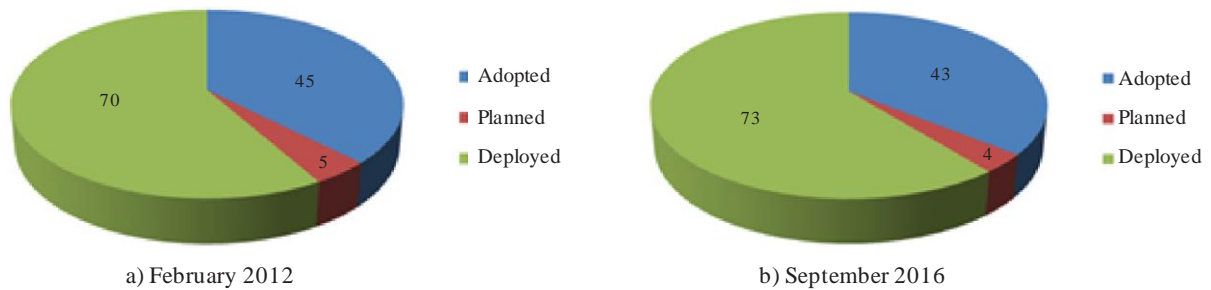

DTTB-09-29

FIGURE 9.30
Introduction of DVB-T2 standard

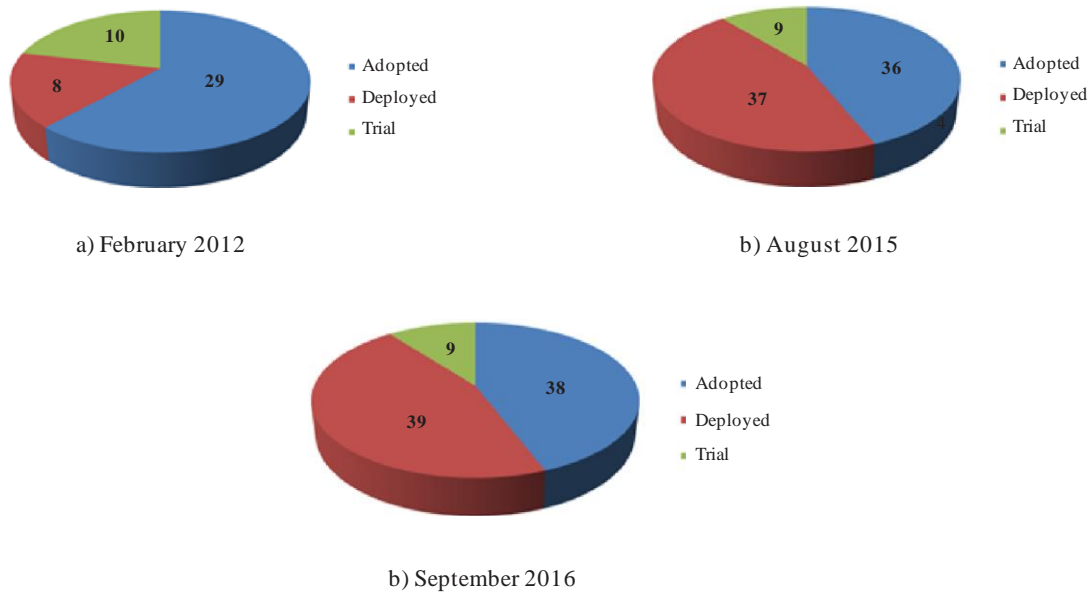

DTTB-09-30

In contrast, DVB-T2 deployment is speeding up. Statistics shows that in the three years from 2012 to 2016, number of deployed networks increased from 8 to 39. In addition, the number of countries that have adopted DVB-T2 standard also increased from 29 to 38.

9.4.1 DVB-T and its mobile TV extensions

Many early DVB systems used DVB-T, so information on this system is provided for completeness. New implementations would be expected to use DVB-T2 (see section 9.4.2).

9.4.1.1 Architectural model and protocol stack for DVB-T/H

An example protocol stack for DVB-T system is provided in Table 9.15. The basic protocol for audio-visual information transmission over physical media is the MPEG-2 transport stream.

TABLE 9.15
Example of protocol stack for DVB-T transmission
of digital television broadcasting

Application (reproduction, recording etc)					
MPEG-4 AVC/HEVC	MPEG-2 Video	MPEG Audio	AC-3, DTS	Subtitles, teletext	EPG, ESG
				PSI	SI
PES MPEG-2				MPEG-2 section	
MPEG-2 Transport Stream					
Physical layer of DVB-T (RS, M-QAM etc.)					

MPEG-2, MPEG-4 AVC or HEVC can be used as compression methods for the video component; AC-3, DTS, MPEG-1, MPEG-2 or MPEG-4 can be used for audio compression. Additionally ancillary elementary streams (subtitles, teletext, etc.) are delivered as data elementary streams in MPEG-2 private sections.

Mobile TV extension for DVB-T. Although the DVB-T transmission system has proven its ability to serve fixed, portable and mobile terminals; handheld terminals (defined as light-weight, battery-powered apparatus with relatively small screen and embedded antenna) require specific features from the transmission system. For this reason, DVB developed a transmission system for handheld terminals (DVB-H). This system is based on the DVB-T standard, with additional DVB H-specific functional blocks. So the DVB-H system will provide the same geographical coverage in comparison with DVB-T and similar network structures with seamless handover between DVB-H cells condition. Such variant of DVB-H system is designated as DVB-T/H. Dedicated DVB-H networks are also possible for implementation.

An example protocol stack for DVB-H system is illustrated in Table 9.16.

TABLE 9.16

Protocol stack of DVB-T/H system

Application layer	Real-time video application	File-based application	ESG
Presentation layer	H.264/MPEG-4 AVC (video) HE-AACv1/v2 (audio)		XML, HTML
Session layer	RTP	FLUTE/ALC	
Transport layer	UDP		
Network layer	IP (IPv4/IPv6)		
Link layer	MPE	Time slicing	MPE-FEC
	Transport stream MPEG-2 TS		
Physical layer	Physical layer DVB-T/H (M-QAM, OFDM, RS, CC)		

MPE and MPE-FEC with IP data and corresponding RS data sections are recovered from MPEG-2 TS transport stream. A typical IP/UDP/RTP stack of IP-based networks is used in the system for unification of the DVB-H system and for access to interactive services. On the presentation layer, video information decoding is based only on MPEG-4 (e.g. H.264/MPEG-4 AVC) and MPEG-1 and MPEG-2 AAC (Advanced Audio Coding) for audio compression.

During file-based application transmission without necessity of immediate consumption of service FLUTE/ALC protocol stack is used in DVB-H system. This protocols used for multicast and unicast datacasting based on IP-protocol (IPDC) to DVB-H. Electronic Service Guide (ESG) is used for service discovery and purchase operations based possibly on XML/HTML presentations.

Satellite assistance for Mobile TV in DVB-T/H framework. DVB-SH, *Digital Video Broadcasting – Satellite services to Handhelds*, is a system which provides IP based media content and data for broadcast services over an hybrid satellite and terrestrial infrastructure operating at frequencies below 3 GHz to a variety of portable and mobile terminals having compact antennas with very limited or no directivity. Target terminals include handheld defined as light-weight and battery-powered apparatus (e.g. PDAs, mobile phones), vehicle-mounted, nomadic (e.g. laptops, palmtops, etc.) and stationary terminals. DVB-SH uses the DVB IP Datacast (IPDC) set of content delivery, electronic service guide and service purchase and protection standards. It includes features such as turbo coding for forward error correction and a highly flexible interleaver in an advanced system designed to cope with the hybrid satellite/terrestrial network topology.

The DVB-SH system coverage is obtained by combining a Satellite Component (SC) and, where necessary, a Complementary Ground Component (CGC) to ensure service continuity in areas where the satellite alone cannot provide the required Quality of Service. The SC ensures wide area coverage while the CGC provides broadcasting type or cellular-type coverage. By this way, all types of environment (outdoor, indoor, urban, suburban and rural) can then be served. It should be noted that the area served by a beam of currently planned multi-beam satellites is in the order of 600 000 km². The hybrid nature of DVB-SH systems has consequences on the several service aspects: handover implementation, service discovery and access, Electronic Service Guide (ESG). It should also be mentioned that the regulations in some countries could allow the deployment of the CGC in anticipation of the satellite launch. The DVB Project published the DVB-SH standard in

February 2007 and was agreed as an ETSI Standard after a public comment process and becomes the ETSI EN 302 583 – *Digital Video Broadcasting (DVB); Framing Structure, channel coding and modulation for Satellite Services to Handheld devices (SH) below 3 GHz*. A list of Complementary standards including the *Implementation* guide (ETSI TS 102 584) is given in the list of relevant documents [9.103-9.110].

9.4.1.2 Key technologies in DVB-T

Key technologies used in DVB-T are following:

- System stream format: modified MPEG-2 transport stream for delivery of information of traditional television applications (subtitles, teletext, electronic programme guide, etc.) with additional information on TV programs, interactive applications, etc.;
- FEC algorithms: concatenated RS(204,188,8) block code and Rate Compatible Punctured Convolutional (RCPC) code (possible code rates: 1/2, 2/3, 3/4, 5/6, 7/8) for providing with interleaving/modulation subsystem of Quasi-Error Free (QEF) mode in which Bit Error Ratio (BER) on inner channel decoder output corresponds to approximately 2×10^{-4} and BER on outer channel decoder corresponds to $10^{-11} - 10^{-12}$;
- Interleaving: two-stage interleaving in convolutional interleaver in time domain (outer interleaving) and bit/symbol frequency interleaver (inner interleaving) for influence reduction of frequency-selective fading and impulse interference;
- Digital modulation: Gray-coded QPSK, 16-QAM, 64-QAM signal constellations providing different trade-off between noise immunity and spectral efficiency;
- Modulation modes: uniform (conventional) signal constellations and non-uniform (hierarchical) signal constellation in which service can be transmitted with different robustness;
- Multipath influence reduction: usage of COFDM with three basic modes (2K and 8K, 4K as extension for DVB-H) and four guard intervals (guard fraction: 1/4, 1/8, 1/16, 1/32) providing possibility of reliable transmission of services for reception in different condition (fixed, portable and mobile reception);
- Channel compensation and automatic configuration: scattered and continuous pilots for channel estimation & compensation, frequency and time synchronization; TPS pilots for automatic receiver configuration (setting for OFDM modes, modulation, coding, etc.);
- Diversity reception for improving receiver performance – optional (not included in baseline standard);
- Channel bandwidth: values of bandwidth is 5 MHz, 6 MHz, 7 MHz and 8 MHz providing possibility of system usage in different frequency plans;
- Supported network modes: single-frequency and multi-frequency networks of different sizes and configurations;
- Special synchronization means in single-frequency network: Mega-Frame Initialization Packet (MIP).

Considering that DVB-H system is based on the DVB-T physical layer, technologies specific to this multimedia broadcasting system are provided below. Other technologies are practically similar to DVB-T technologies.

DVB-H technical solutions are following:

- Receiver power consumption reduction: time slicing for power saving by decoding of only part of shared stream containing data of required service Reduction of power consumption with particular DVB-H link layer parameters (burst size, burst duration, off-time, etc.) is corresponding to approximately 90%.
- Multiprotocol Encapsulation (MPE): main difference DVB-H from DVB-T is IP-datagram based transmission of information of any service. IP datagrams is encapsulated in MPEG-2 TS by MPE procedure.

- Forward Error Correction for Multiprotocol Encapsulated (MPE-FEC) data: optional MPE-FEC technology allows improve C/N threshold value on which receiver operate in Quasi-Error Free (QEF) mode and reduce influence of Doppler effect during multi-path reception. This obtained by inclusion of additional error correction on MPE-level with usage of Reed-Solomon code (block code rates 1/1 (no coding), 1/2, 2/3, 3/4, 5/6, 7/8). So possibility of choice of different channel code rates it is provided thus required trade-off between noise immunity and information data rate is obtained.
- Extended set of OFDM modes: additional transmission mode used in DVB-H system at physical layer is 4k mode. It defined for increasing flexibility in network planning obtained by trade-off between mobility of receiver terminal and cell sizes in single-frequency network.
- Extended set of interleaving schemes: additionally to interleaving schemes used in DVB-T, in-depth symbol interleaver (choice between in native and in-depth interleaver – inner interleaver in DVB-T) is used in DVB-H system. Besides, during DVB-H framing the virtual block interleaving of MPE and MPE-FEC sections with interleaving depth depending on frame size is implemented.
- Enhanced TPS system: for signalling of elementary stream parameters in DVB-H multiplex the TPS channel defined in DVB-T is used. Reserved data channel with information on availability of DVB-H time-sliced elementary streams in shared multiplex and MPE-FEC usage.

Key technologies for DVB-SH system are following (in addition to DVB-T/H features that considered as Terrestrial Segment):

- Extended access methods to broadcasting channel: TDM and FDM modes are used in different segments of full network;
- Improved error correction: DVB-SH uses 3GPP turbo code with code rates 1/5, 2/9, 1/4, 2/7, 1/3, 2/5, 1/2, 2/3 as error correction in satellite network segment;
- Extended bandwidth and modulation: DVB-SH defines usage of 1.7 MHz bandwidth and QPSK, 8-PSK, 16-APSK.

9.4.1.3 Physical layer for DVB-T and Mobile TV extension

The DVB-T specification offers a range of deliverable net bit-rates from 4.98 Mbit/s to 31.67 Mbit/s (see ETSI EN 300 744 [9.36]).

The following processes shall be applied to the data stream at physical layer of DVB-T:

- Transport multiplex adaptation and randomization for energy dispersal;
- Outer coding (i.e. Reed-Solomon code);
- Outer interleaving (i.e. convolutional interleaving);
- Inner coding (i.e. punctured convolutional code);
- Inner interleaving (either native or in-depth);
- Mapping and modulation;
- Orthogonal Frequency Division Multiplexing (OFDM) transmission.

Adaptation path of DVB-T system is illustrated on Figure 9.31. Considering that terrestrial channel is characterized by high level of noise and interference adaptation path is more complex in comparison on digital broadcasting systems in other programme distribution environments (cable and satellite). Block diagram contains second parallel path used for hierarchical transmission mode (on figure it is highlighted by a dotted line).

Since the system is being designed for digital terrestrial television services to operate within the existing VHF and UHF spectrum allocation for analogue transmissions, it is required that the System provides sufficient protection against high levels of Co-Channel Interference (CCI) and Adjacent Channel Interference (ACI) emanating from existing PAL/SECAM/NTSC services. It is also a requirement that the System allows the maximum spectrum efficiency when used within the VHF and UHF bands; this requirement can be achieved by utilizing Single Frequency Network (SFN) operation.

FIGURE 9.31

Adaptation path of DVB-T digital terrestrial television broadcasting system

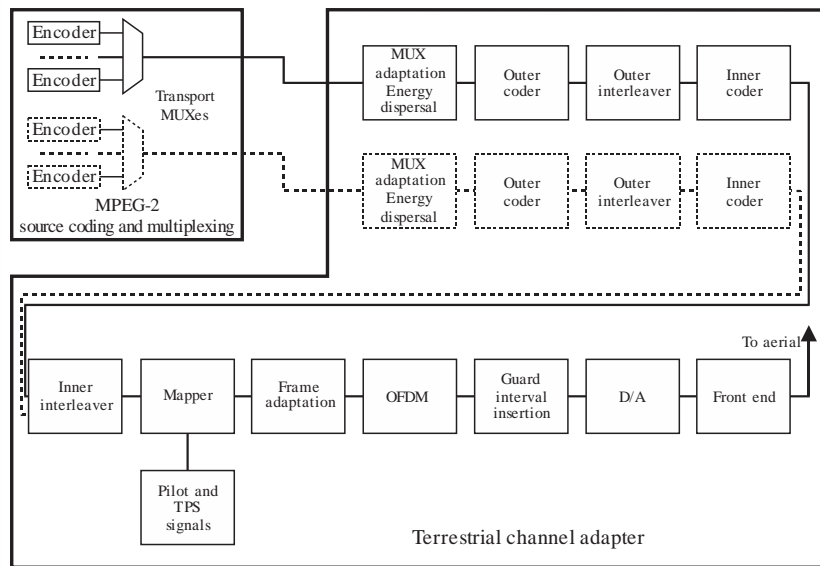

DTTB-09-31

To achieve these requirements an OFDM system with concatenated error correcting coding is being specified. To maximize commonality with the Satellite baseline specification (see EN 300 421) and Cable baseline specifications (see EN 300 429) the outer coding and outer interleaving are common, and the inner coding is common with the Satellite baseline specification. To allow optimal trade-off between network topology and frequency efficiency, a flexible guard interval is specified. This will enable the system to support different network configurations, such as large area SFN and single transmitter, while keeping maximum frequency efficiency.

Two modes of operation, a “2k mode” and an “8k mode”, are defined for DVB-T and DVB-H transmissions. The “2k mode” is suitable for single transmitter operation and for small SFN networks with limited transmitter distances. The “8k mode” can be used both for single transmitter operation and for small and large SFN networks.

Exclusively for use in DVB-H systems, a third transmission mode the “4k mode” is defined in Annex F, addressing the specific needs of Handheld terminals. The “4k mode” aims to offer an additional trade-off between transmission cell size and mobile reception capabilities, providing an additional degree of flexibility for DVB-H network planning.

The system allows different levels of QAM modulation and different inner code rates to be used to trade bit rate versus ruggedness. The system also allows two level hierarchical channel coding and modulation, including uniform and multi-resolution constellation. In this case, the functional block diagram of the system shall be expanded to include the modules shown dashed in Figure 9.31. Two independent MPEG transport streams, referred to as the high-priority and the low-priority stream, are mapped onto the signal constellation by the Mapper and the Modulator which therefore has a corresponding number of inputs.

To guarantee that the signals emitted by such hierarchical systems may be received by a simple receiver, the hierarchical nature is restricted to hierarchical channel coding and modulation without the use of hierarchical source coding.

A programme service can thus be “simulcast” as a low-bit-rate, rugged version and another version of higher bit rate and lesser ruggedness. Alternatively, entirely different programmes can be transmitted on the separate streams with different ruggedness. In either case, the receiver requires only one set of the inverse elements: inner de-interleaver, inner decoder, outer de-interleaver, outer decoder and multiplex adaptation. The only additional requirement thus placed on the receiver is the ability for the demodulator/de-mapper to produce one stream selected from those mapped at the sending end.

The price for this receiver economy is that reception cannot switch from one layer to another (e.g. to select the more rugged layer in the event of reception becoming degraded) while continuously decoding and presenting pictures and sound. A pause is necessary (e.g. video freeze frame for approximately 0.5 seconds, audio interruption for approximately 0.2 seconds) while the inner decoder and the various source decoders are suitably reconfigured and reacquire lock.

More detailed information on processing of MPEG-2 TS in DVB-T adaptation path is provided in ETSI EN 300 744 [9.36] and ETSI TR 101 190. Other useful information on DVB-T implementation is provided in [9.166, 9.167].

DVB-T mobile reception based on diversity technologies. In its simplest form, antenna diversity is achieved in a receiver that demodulates, in parallel, the signals of more than one (typically two to four) receiving antennas. The best output of these received signals (normally that with the lowest BER) is then further processed. A technically remarkable step ahead uses the principle of Coherent Carrier Summation (CCS), where the COFDM signals of the various receiving antennas are combined in coherent form prior to demodulation. This was demonstrated in Italy and is reported in more detail in [9.74]. Weighted summation can also be accomplished at the baseband level as demonstrated in Japan (see section 9.5.2). For both combination methods, significant improvements are achieved to overcome selective fading and reduction in C/N .

Test results show that diversity significantly improves reception performance in comparison with “classical” single antenna reception³⁰. Different variants of diversity reception are possible (Maximum Ratio Combining, Coherent Carrier Summation, etc.). Table 9.17 shows the results of some DVB-T reception tests, with CCS diversity and without, expressed both as the number of video breakdowns and as a percentage of the total time of successful reception of each measured path.

TABLE 9.17

Result of diversity reception test for DVB-T standard

Path	Total breakdowns		Percentage T_{on}/T_{total}	
	Single antenna	CCS	Single antenna	CCS
Agrate – Dalmine	5	1	13%	100%
Dalmine – RaiWay Control Centre Monza	18	3	15%	98%
RaiWay Control Centre Monza – Sesto Calende (A4, A8, A26)	22	15	25%	90%
Sesto Calende – RaiWay Control Centre Monza (A26, A8, Tang. Nord)	46	6	43%	95%
Milano – Outer City Path (“Terzo anello”)	114	10	51%	99%
Milano – Inner City Path (Historical Centre)	75	34	36%	91%

The basic elements of the link layer specific to the DVB-H system are time-slicing and Forward Error Correction for multi-protocol encapsulated data (MPE-FEC). The basic elements of the physical layer defined in the DVB-T system are Transmission Parameters Signalling (TPS), 4k transmission mode and in-depth symbol interleaver.

Transmission on the DVB-T physical layer is implemented by means of OFDM with multiple carriers. Only one new physical layer element is defined for DVB-H in comparison with DVB-T: extended TPS signalization system for DVB-H elementary streams in a shared multiplex. The DVB-H data stream is also compatible with the DVB transport stream.

³⁰ Similar improvements in performance would be expected for other DTTB systems using diversity reception.

In addition to transmission of multimedia broadcasting in terrestrial broadcasting networks DVB-H is used as terrestrial segment of DVB-SH hybrid multimedia broadcasting system.

The physical layer of DVB-H is based on the physical layer of DVB-T system except for input IP streams consisting of IP datagrams. The reference architecture for the DVB-H physical layer is provided in Figure 9.32.

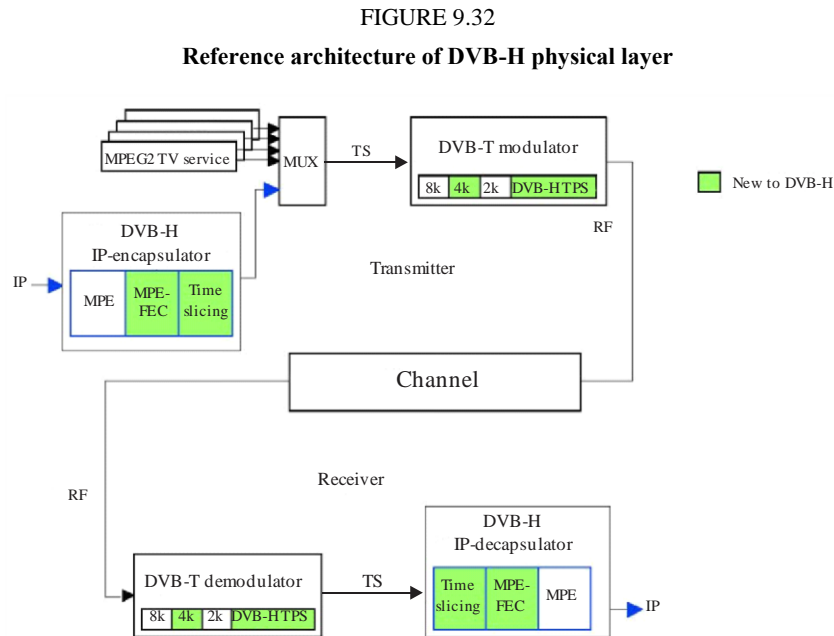

In this case, typical MPEG-2 TV services and DVB-H time-sliced services may be transmitted in a shared multiplex. DVB-H services can be transmitted using the full multiplex capacity (i.e. a dedicated DVB-H network). As shown in Figure 9.32, handheld terminals decode and process only the services based on the IP-protocol. A DVB-T demodulator supporting 2k, 4k and 8k modes with related DVB-H TPS recovers packets of MPEG-2 transport stream from the RF signal. The time slicing module is used for power consumption reduction and smooth/seamless service handover in the DVB-H system. The MPE-FEC module, provided by DVB-H, offers additional robustness over the physical layer transmission.

As time slicing and MPE-FEC constitute processes applied at the Link layer (OSI Layer 2) they do not raise any incompatibility issues and are fully compatible with the existing DVB Physical layer (OSI layer 1) (i.e. DVB-T, DVB-S and DVB-C).

Physical layer for satellite assistance based system. The DVB-SH system is designed for frequencies below 3 GHz, supporting UHF band, L Band or S-band. It complements and improves the existing DVB-H physical layer standard as described in ETSI EN 302 304 [9.111].

The DVB-SH standard specifies two operational modes:

- SH-A: specifies the use of COFDM modulation on both satellite and terrestrial links with the possibility of running both links in SFN configuration. This mode can be used on both the direct and indirect paths; the two signals are combined in the receiver to strengthen the reception in a SFN configuration.
- SH-B: uses Time-Division Multiplexing (TDM) on the satellite link and COFDM on the terrestrial link. This mode is used on the direct path only. The system supports code diversity recombination between satellite TDM and terrestrial OFDM modes so as to increase the robustness of the transmission in relevant areas (mainly suburban).

Figure 9.33 shows the general view of a typical implementation of a DVB-SH system.

In the first case, SH-B takes advantage of satellite transponders operated in full saturation while SH-A requires satellite transponders operated in a quasi-linear mode. In the second case, SH-B provides little or no performance advantage over SH-A. Beyond these pure performance considerations, the choice between SH-A and SH-B may be essentially driven by frequency planning constraints as outlined below, or by the flexibility gained when decoupling satellite transmission parameters from the terrestrial ones.

According to mentioned above, two different receiver architectures can be distinguished according to the DVB-SH waveform options, respectively the OFDM/OFDM (SH-A) and the TDM/OFDM (SH-B) system architectures.

FIGURE 9.33
General view of a typical implementation of DVB-SH

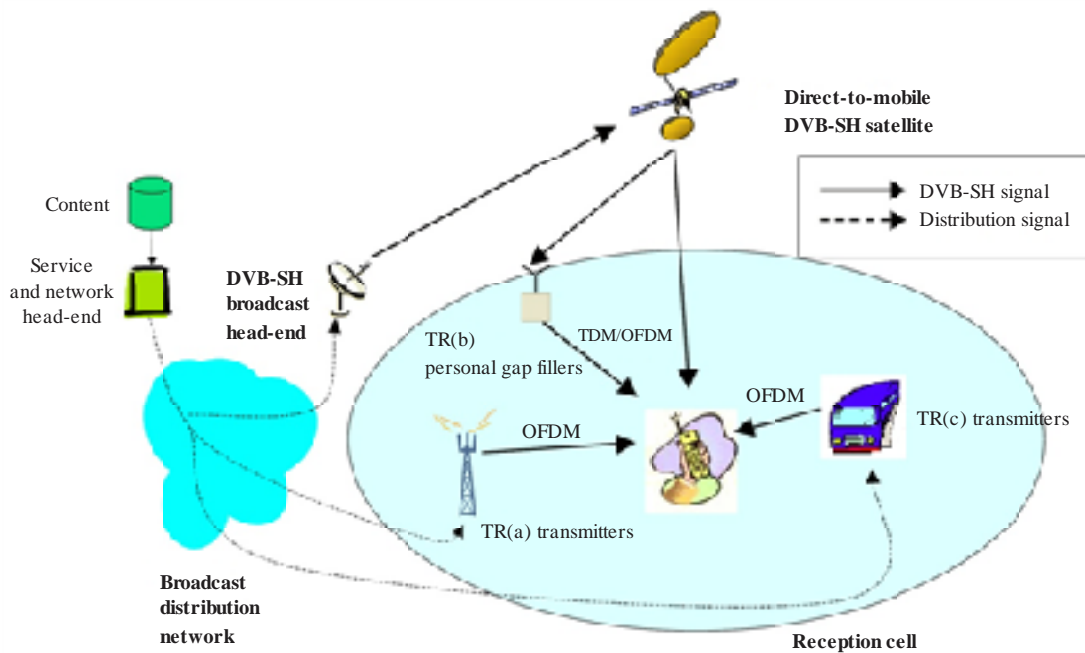

DTTB-09-33

Figure taken from ETSI TS 102 584.

The main characteristics of DVB-SH Physical layer are summarized in the following Table 9.18.

TABLE 9.18

Main characteristics of DVB-SH Physical and Network Layer

Band	UHF, L and S band
Bandwidths	1.7, 5, 6, 8 MHz
Synchronization	Pilot carriers (DVB-H like) or TDM
Waveforms	TDM or OFDM (1k, 2k, 4k, 8k)
OFDM mapping	QPSK; 16 QAM
TDM Mapping	QPSK; 8PSK; 16APSK
Inner coding	turbo coding
Inner interleaving	small
Time interleaving	150 ms to 10 s (PHY + iFEC)
Frame structure	Service/time slice/OFDM symbols

DVB-SH Topological configuration. This consists in allocating the sub-bands to the topological elements, i.e. the satellite beam(s) and the terrestrial cells. Adjacent beams must not have common frequencies for interfering avoidance reasons. This is the same for adjacent cells. However, it is possible to reuse these frequencies:

- a frequency used in a beam/cell can be reused in another beam/cell if this beam/cell is sufficiently separated from the first;
- terrestrial cells can reuse an adjacent beam frequency provided they these cells are sufficiently far away from this beam.

Actual frequency allocation to sub-bands may be quite complex due to possible interferences from the satellite adjacent spot beams. In particular, for reusing adjacent spot beam frequency, terrestrial reuse is sought in the centre of the spot (far from the borders) but this is not always possible.

There are two main approaches for configuring the Complementary Ground Component (CGC) network of transmitters:

- the "high-density", "low-power" approach attempts to reuse, all or partially, existing 3G/2G transmitter sites, or to build an equivalent low to medium height type of transmitters network. These networks are characterized by transmitter towers of typically 30 meter high delivering from 200 W to 1 kW ERP for dense urban coverage in the range of 0.5 km (deep indoor) to 2 km (outdoor);
- the "low-density", "high-power" approach attempts to reuse existing digital terrestrial TV transmitter sites, or to build an equivalent high-altitude transmitters networks. These networks are characterized by transmitter towers of 100 to 300 meters high, delivering 1 kW to 4 kW ERP for typical coverage in the range from 5 km to 7 km.

Further Detailed information can be found in the ETSI Standards and especially in the ETSI TS 102 584 – *Guidelines for Implementation for Satellite Services to Handheld devices (SH) below 3GHz* [9.106].

9.4.1.4 Performance of DVB-T system and Mobile TV extension

In summary, the following parameters can be chosen in the DVB-T system:

- Code rate of inner error protection (1/2, 2/3, 3/4, 5/6, 7/8);
- Carrier modulation (QPSK: 2 bits per carrier; 16-QAM: 4 bits; 64-QAM: 6 bits);
- Guard interval length (1/4, 1/8, 1/16, 1/32);
- Modulation parameter α (1: non-hierarchical; 2, 4: hierarchical);
- FFT length; number of carriers (2k: 1 705 carriers; 4k: 3 409 carriers; 8k: 6 817 carriers).

Set of this parameters are forming space of configuration providing particular trade-off between noise immunity and net bit-rate in broadcasting network. On Figure 9.34 such trade-off is illustrated for each of three modulation methods in AWGN channel. This curves are obtained by simulation [9.153] and threshold values of C/N ratios (in QEF mode) are correspond to ETSI EN 300 744 v.1.6.1 [9.36]

Additionally, threshold values of C/N ratios and MPEG-2 TS rates are defined in Table 9.19. For additional information on DVB-T performance in hierarchical mode see ETSI EN 300 744 [9.36].

FIGURE 9.34

Dependency of BER after Viterbi inner decoder on C/N ratio for modes with QPSK (a), 16-QAM (b) and 64-QAM (c)

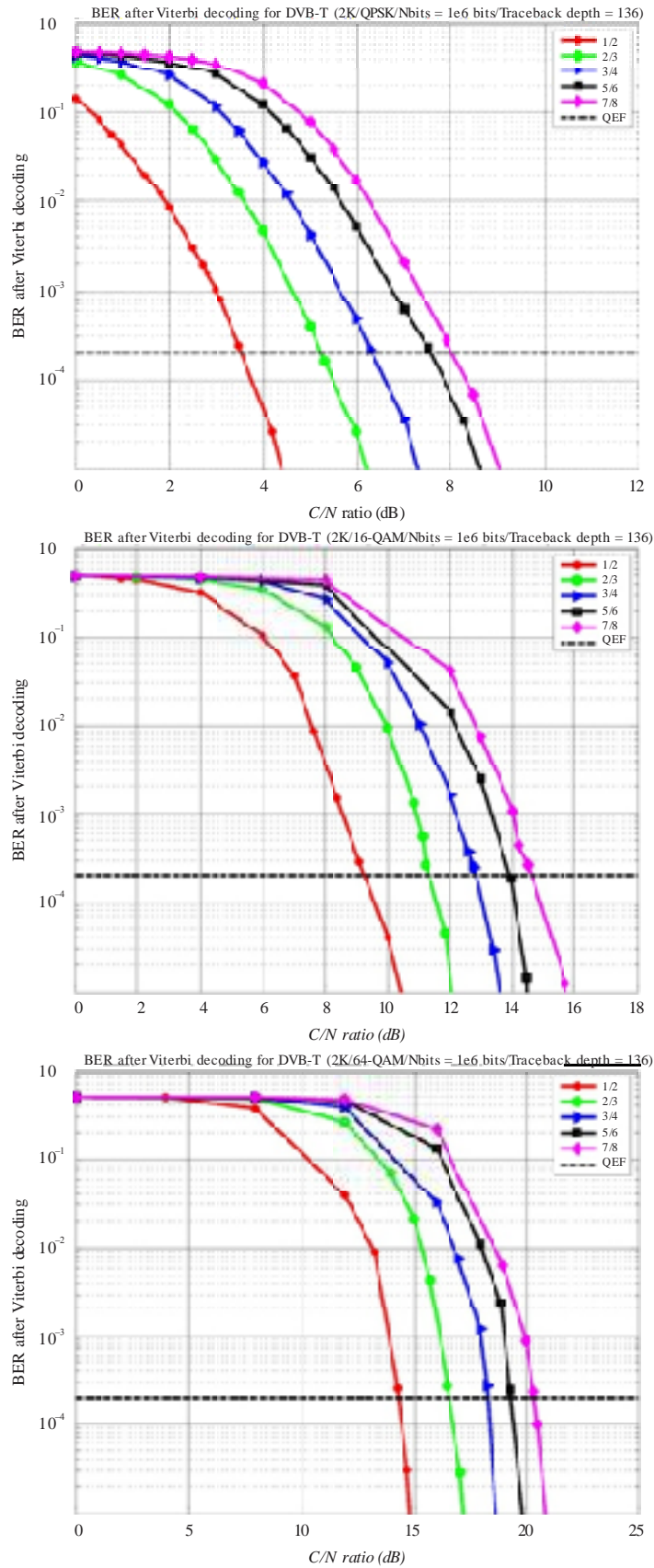

TABLE 9.19

**Required C/N for Non-Hierarchical transmission
to achieve a BER = 2×10^{-4} after the Viterbi decoder**

Modulation	Code rate	Required C/N (dB) for BER = 2×10^{-4} after Viterbi, QEF after Reed-Solomon			Bit-rate (Mbit/s) (see Note 3)			
		Gaussian channel	Ricean channel	Rayleigh channel	$\Delta/T_U = 1/4$	$\Delta/T_U = 1/8$	$\Delta/T_U = 1/16$	$\Delta/T_U = 1/32$
QPSK	1/2	3.1	3.6	5.4	4.98	5.53	5.85	6.03
QPSK	2/3	4.9	5.7	8.4	6.64	7.37	7.81	8.04
QPSK	3/4	5.9	6.8	10.7	7.46	8.29	8.78	9.05
QPSK	5/6	6.9	8.0	13.1	8.29	9.22	9.76	10.05
QPSK	7/8	7.7	8.7	16.3	8.71	9.68	10.25	10.56
16-QAM	1/2	8.8	9.6	11.2	9.95	11.06	11.71	12.06
16-QAM	2/3	11.1	11.6	14.2	13.27	14.75	15.61	16.09
16-QAM	3/4	12.5	13.0	16.7	14.93	16.59	17.56	18.10
16-QAM	5/6	13.5	14.4	19.3	16.59	18.43	19.52	20.11
16-QAM	7/8	13.9	15.0	22.8	17.42	19.35	20.49	21.11
64-QAM	1/2	14.4	14.7	16.0	14.93	16.59	17.56	18.10
64-QAM	2/3	16.5	17.1	19.3	19.91	22.12	23.42	24.13
64-QAM	3/4	18.0	18.6	21.7	22.39	24.88	26.35	27.14
64-QAM	5/6	19.3	20.0	25.3	24.88	27.65	29.27	30.16
64-QAM	7/8	20.1	21.0	27.9	26.13	29.03	30.74	31.67

NOTE 1 – Quasi Error Free (QEF) means less than one uncorrected error event per hour, corresponding to BER = 10^{-11} at the input of the MPEG-2 demultiplexer.

NOTE 2 – Net bit rates are given after the Reed-Solomon decoder.

DVB-H performance depends both on link layer parameters and DVB-T configuration. For providing sufficient C/N gain and mobility of terminal typical choice of digital modulation order not higher than 16-QAM and DVB-T convolutional code rate not higher than 1/2, 2/3 or 3/4. Usage of other DVB-T system configurations is also possible – the choice is up to organizations deploying DVB-T/H networks – but with some restrictions. Guidelines for link and physical layer configurations are provided in the main DVB-H standards.

Net data-rates for DVB-T/H are defined by corresponding scaling of DVB-T net data-rates with scaling factor depending on relative MPE-FEC code rate. Example of net data-rates with MPE-FEC 1/2 code rate and full 8 MHz bandwidth for DVB-H services is provided in Table 9.20.

TABLE 9.20

Net data-rates for DVB-T/H (with MPE-FEC 1/2 code rate)

Modulation	Code rate	Guard interval			
		1/4	1/8	1/16	1/32
QPSK	1/2	2.48	2.76	2.92	3.01
	2/3	3.31	3.68	3.89	4.01
	3/4	3.72	4.14	4.38	4.51
	5/6	4.14	4.6	4.87	5.02
	7/8	4.34	4.83	5.11	5.27
16-QAM	1/2	4.97	5.52	5.84	6.02
	2/3	6.62	7.36	7.79	8.03
	3/4	7.45	8.28	8.76	9.03
	5/6	8.28	9.2	9.74	10.03
	7/8	8.69	9.66	10.23	10.54
64-QAM	1/2	7.45	8.28	8.76	9.03
	2/3	9.93	11.04	11.69	12.04
	3/4	11.18	12.42	13.15	13.55
	5/6	12.42	13.8	14.61	15.05
	7/8	13.04	14.49	15.34	15.80

The DVB-H receiver is expected to have the performance given in Table 9.21, when noise (N) is applied together with the wanted carrier (C) in a signal bandwidth of 7.61 MHz. Degradation point criteria is MPE Frame Error Rate (MFER) 5%. The values are calculated using the theoretical C/N figures given in EN 300 744 [9.36] added by an implementation margin of 1.1 dB for QPSK, 1.3 dB for 16-QAM and 1.5 dB for 64-QAM modes and a receiver excess noise source value P_x of -33 dBc. An ideal transmitter is assumed. The values are valid for all MPE-FEC code rates. A 1 dB difference between DVB-T QEF C/N and MFER % is assumed.

TABLE 9.21

C/N (dB) for 5% MFER in Gaussian Channel

Modulation	Code rate	Required C/N (dB)			Bit-rate (Mbit/s)			
		Gaussian channel	Ricean channel	Rayleigh channel	$\Delta/T_U = 1/4$	$\Delta/T_U = 1/8$	$\Delta/T_U = 1/16$	$\Delta/T_U = 1/32$
QPSK	1/2	3.6	3.6	6.5	2.48	2.76	2.92	3.01
QPSK	2/3	5.4	5.7	10.5	3.31	3.68	3.89	4.01
16-QAM	1/2	9.6	9.6	12.8	4.97	5.52	5.84	6.02
16-QAM	2/3	11.7	11.6	16.7	6.62	7.36	7.79	8.03
64-QAM	1/2	14.4	14.7	17.9	7.45	8.28	8.76	9.03
64-QAM	2/3	17.3	17.1	22.4	9.93	11.04	11.69	12.04

9.4.1.5 Summary of system parameters

Table 9.22 defines characteristics of DVB-T and DVB-H systems (see also Report ITU-R BT.2295-1 [9.43]).

TABLE 9.22

Key characteristics of DVB-T, DVB-H and DVB-SH systems

Characteristics	DVB-T, DVB-H, DVB-SH
Reception modes: – Fixed – Portable – Portable handheld – Mobile	+ + + +
Net data rates	a) 0.42 to 3.447 Mbit/s ¹ b) 1.332 to 10.772 Mbit/s ¹ ; 2.33 to 14.89 Mbit/s ² c) 1.60 to 12.95 Mbit/s ¹ ; 2.80 to 23.5 Mbit/s ² d) 1.868 to 15.103 Mbit/s ¹ ; 3.27 to 27.71 Mbit/s ² e) 2.135 to 17.257 Mbit/s ¹ ; 3.74 to 31.67 Mbit/s
Spectrum efficiency (bit/s/Hz)	0.28-2.44 ¹ 0.46-1.86 ²
Single frequency networks	Supported
Broadcasting types: – sound – multimedia – TV	+ +
Transmission data/service types	Video, audio, data
Frequency bands	VHF, UHF
Channel bandwidth	a) 1.7 MHz ¹ b) 5 MHz c) 6 MHz d) 7 MHz e) 8 MHz
Used bandwidth	a) 1.52 MHz ¹ b) 4.75 MHz c) 5.71 MHz d) 6.66 MHz e) 7.61 MHz TDM ¹ : a) 1.368 MHz b) 4.27 MHz c) 5.13 MHz d) 5.18 MHz e) 6.838 MHz
Number of segments	Configurable number of time slices per bandwidth ¹
Number of subcarriers per segment	853 (1k mode) ¹ ; 1 705 (2k mode); 3 409 (4k mode); 6 817 (8k mode)
Subcarrier spacing	a) 1 786 kHz (1k) ¹ b) 5 580.322 Hz (1k) ¹ , 2 790.179 Hz (2k), 1 395.089 Hz (4k), 697.545 Hz (8k) c) 6 696.42 Hz (1k) ¹ , 3 348.21 Hz (2k), 1 674.11 Hz (4k), 837.05 Hz (8k) d) 7 812 Hz (1k) ¹ , 3 906 Hz (2k), 1 953 Hz (4k), 976 Hz (8k) e) 8 929 Hz (1k) ¹ , 4 464 Hz (2k), 2 232 Hz (4k), 1 116 Hz (8k)
Active symbol duration	a) 560 μs (1k) ¹ b) 179.2 μs (1k) ¹ , 358.40 μs (2k), 716.80 μs (4k), 1 433.60 μs (8k) c) 149.33 μs (1k) ¹ , 298.67 μs (2k), 597.33 μs (4k), 1 194.67 μs (8k) d) 2 128 μs (1k) ¹ , 256 μs (2k), 512 μs (4k), 1 024 μs (8k) e) 112 μs (1k) ¹ , 224 μs (2k), 448 μs (4k), 896 μs (8k)
Guard interval duration/ ratio	1/32, 1/16, 1/8, 1/4

TABLE 9.22 (end)

Characteristics	DVB-T, DVB-H, DVB-SH
Frame duration	68 OFDM symbols. One super-frame consists of 4 frames. TDM ¹ : 476 physical layer slots, each of them comprising 2 176 symbols
Time/ frequency synchronization	Guard interval/ Pilot carriers TDM ¹ : Pilot symbols
Modulation methods	QPSK, 16-QAM, 64-QAM, MR-16-QAM, MR-64-QAM ² TDM ¹ : QPSK, 8-PSK, 16-APSK
Inner FEC	a) Convolution code, mother rate 1/2 with 64 states. Puncturing to rate 2/3, 3/4, 5/6, 7/8 ⁴ b) Turbo Code from 3GPP2 with mother information block size of 12 282 bits. Rates obtained by puncturing: 1/5, 2/9, 1/4, 2/7, 1/3, 2/5, 1/2, 2/3 ³
Inner interleaving	a) Bit interleaving, combined with native or in-depth symbol interleaving ² b) Frequency interleaving; Time interleaving (Forney with 48 branches QPSK: 320/ 9 600 ms 16-QAM:160/ 4 800 ms) ¹
Outer FEC	Outer Code: RS (204, 188, T = 8) ² IP outer channel code: MPE-FEC RS (255,191) ¹
Outer interleaving	Byte-wise convolutional interleaving, I = 12 ¹
Data randomization/ energy dispersal	16 bit PRBS
Hierarchical transmission	+
Transmission parameter signalling	TPS pilot carriers

¹ Available for DVB-SH.² Available for DVB-T, DVB-H.

9.4.1.6 Link budget

Some examples of link budget for DVB-T/H is provided in ETSI TR 102 377 [9.114]. For illustrating link budget minimum median power flux density and equivalent minimum median field strength values for terminal category 3 (Handheld Portable Convergence Terminals) and different receiving modes was extracted from [9.114] (see Tables 9.23 and 9.24). Information on link budgets in other reception modes is provided in [9.114].

TABLE 9.23

**Minimum median power flux density and equivalent minimum median field strength
in Band IV and 70% and 95% location probability**

Receiving condition: Portable outdoor (Class A), Urban, Band IV, terminal category 3

Frequency Minimum C/N required by system	f (MHz) (dB)	500				
		2	8	14	20	26
Min. receiver signal input power	$P_{s \min}$ (dBW)	-127,2	-121,2	-115,2	-109,2	-103,2
Min. equivalent receiver input voltage, 75 Ω	$U_{s \min}$ (dBW)	12	18	24	30	36
Antenna gain relative to half dipole	U_a (dB)	-12				
Effective Antenna aperture	A_a (dBm ²)	-25,3				
Min. power flux density at receiving location	ϕ_{\min} (dBW/m ²)	-101,9	-95,9	-89,9	-83,9	-77,9
Min. equivalent field strength at receiving location	E_{\min} (dB μ V/m)	44	50	56	62	68
Allowance for manmade noise	P_{mmn} (dB)	0				
Height loss	L_h (dB)	22				
Location Probability: 70 %						
Location correction factor	C_l (dB)	3				
Minimum median power flux density at 10 m a.g.l. 50 % of time and 50 % of location	ϕ_{med} (dBW/m ²)	-76,9	-70,9	-64,9	-58,9	-52,9
Minimum median equivalent field strength at 10 m a.g.l. 50 % of time and 50 % of location	E_{med} (dB μ V/m)	69	75	81	87	93
Location Probability: 95 %						
Location correction factor	C_l (dB)	9				
Minimum median power flux density at 10 m a.g.l. 50 % of time and 50 % of location	ϕ_{med} (dBW/m ²)	-70,9	-64,9	-58,9	-52,9	-46,9
Minimum median equivalent field strength at 10 m a.g.l. 50 % of time and 50 % of location	E_{med} (dB μ V/m)	75	81	87	93	99

TABLE 9.24

**Minimum median power flux-density and equivalent minimum median field strength
in Band V and 70% and 95% location probability**

Receiving condition: Portable outdoor (Class A), Urban, Band V, terminal category 3

Frequency Minimum C/N required by system	f (MHz) (dB)	800				
		2	8	14	20	26
Min. receiver signal input power	$P_{s \min}$ (dBW)	-127,2	-121,2	-115,2	-109,2	-103,2
Min. equivalent receiver input voltage, 75 Ω	$U_{s \min}$ (dBW)	12	18	24	30	36
Antenna gain relative to half dipole	U_a (dB)	-7				
Effective Antenna aperture	A_a (dBm ²)	-24,4				
Min. power flux density at receiving location	ϕ_{\min} (dBW/m ²)	-102,8	-96,8	-90,8	-84,8	-78,8
Min. equivalent field strength at receiving location	E_{\min} (dB μ V/m)	43	49	55	61	67
Allowance for manmade noise	P_{mmn} (dB)	0				
Height loss	L_h (dB)	24				
Location Probability: 70 %						
Location correction factor	C_l (dB)	3				
Minimum median power flux density at 1,5 m a.g.l. 50 % of time and 50 % of location	ϕ_{med} (dBW/m ²)	-75,8	-69,8	-63,8	-57,8	-51,8
Minimum median equivalent field strength at 1,5 m a.g.l. 50 % of time and 50 % of location	E_{med} (dB μ V/m)	70	76	82	88	94
Location Probability: 95 %						
Location correction factor	C_l (dB)	9				
Minimum median power flux density at 10 m a.g.l. 50 % of time and 50 % of location	ϕ_{med} (dBW/m ²)	-69,8	-63,8	-57,8	-51,8	-45,8
Minimum median equivalent field strength at 10 m a.g.l. 50 % of time and 50 % of location	E_{med} (dB μ V/m)	76	82	88	94	100

The ETSI TR 102 584 Implementation guidelines for satellite services to Handheld devices (DVB-SH) below 3 GHz describes in details the methodology for establishing the link budget in different scenarios of implementation of networks.

9.4.1.7 Example of possible use of DVB-T system

There exist several websites (see, for example, [9.173]) which publish the actual composition of DTTB multiplexes. By using a TS Analyser, all relevant parameters can be deduced. A typical measurement provides, *inter alia*, the following parameters (example of Multiplex A in Slovenia, dated as of 5th October 2016):

- Multiplex A: Six broadcasting services (4 SD and 2 HD services):
 - Central frequency: 562 MHz;
 - Constellation: 64-QAM;
 - Code rate: 2/3;
 - FFT mode: 8k;
 - Guard interval: 1/4;
 - Total calculated useful bit-rate: 19.9053 Mbit/s.

Compression system: MPEG-4 part 10 (AVC/H.264) and MPEG-4 part 3 (AAC); to cope with legacy equipment, audio coding MPEG-1 Layer II is also provided.

It is expected that, gradually, DVB-T broadcasting services will be replaced by DVB-T2 in combination with the video compression scheme HEVC (H.265) because of its higher spectrum efficiency. Such digital-to-digital switch-over may be accomplished with a certain period of transition where DVB-T and DVB-T2 are provided in simulcast configuration, or it may happen step-by-step where a DVB-T transmitter is switched off each time a DVB-T2 service has started in a given area. In any case, due notice must be given to the public in good time prior to the switch-off as new set-top boxes or TV sets need to be installed.

As an example, since June 2016, in Germany DVB-T2/HEVC (HDTV only) is aired pre-operationally in more than 20 cities and agglomerations. On 29 March 2017, the service will be declared operational. By mid-2019 at the latest, nation-wide coverage of DVB-T2/HEVC will have been achieved. After the start of the operational DVB-T2/HEVC service, DVB-T/MPEG-2 will be switched off at any location where DVB-T2 has started. Whilst featuring about the same robustness, each multiplex (64-QAM) will contain at least 5 HDTV (1080p50) programmes (plus additional services and support for HbbTV). This is to be seen in comparison to the four SDTV programmes per multiplex of the current DVB-T/MPEG-2 (16-QAM) service. The useful data-rates of the German DVB-T2/HEVC services are similar to those in Slovenia (around 20 Mbit/s).

9.4.2 DVB-T2 and its mobile TV extensions

Digital Video Broadcasting – Second Generation Terrestrial (DVB-T2) is a second-generation terrestrial transmission system for digital television broadcasting. It builds on the technologies used as part of the first-generation system, DVB-T.

DVB-T2 technology provides increased flexibility in the choice of system parameters such as the COFDM parameters (FFT sizes, Guard Interval durations, number of carriers (normal and extended)), the new FEC schemes and code rates, modulations for digital terrestrial broadcasting, channel bandwidths, etc. This flexibility gives greater choice in the trade-off between network planning, information rates and robustness of the digital terrestrial television reception.

Additionally, DVB-T2 significantly reduces overhead (compared with DVB-T) to build a system with a throughput close to theoretical channel capacity, with the best possible ruggedness of transmission. The key motivation behind this standard was the desire in several European countries to offer high definition television (HDTV) services as efficiently and effectively as possible. The move to HDTV inevitably brings with it a change of source coding, necessitating the introduction of new domestic reception equipment (set-top boxes and TV sets), and therefore offers an ideal opportunity to upgrade the transmission system simultaneously.

Also DVB-T2 system provides possibility for implementation of Mobile TV services based on specific set of system parameters. Such mode (system) is called DVB-T2 Lite. According to Recommendation ITU-R BT.1833 [9.35], DVB-T2 Lite (known as ITU-R Multimedia System T2) is defined as follows:

“End-to-end broadcast system for delivery of multimedia broadcasting signal to handheld devices based on physical layer pipes (PLP) concept with T2 time slicing technology. This system is designed to optimize and sufficiently improve efficiency of multimedia broadcasting system in trade-off between system parameters such as C/N performance, bit-rate, receiver complexity, etc. enables the simulcasting of two different versions of the same service, with different bit-rates and levels of protection, which would allow better reception in fringe areas”.

Introduction of T2-Lite can enable vehicular reception at higher velocities with more robust FFT modes and pilot patterns, and can also improve the coverage of handheld receivers by using code rates below 1/2. This results in a deployment scenario where mobile services are simulcasted with lower quality by means of T2-Lite.

9.4.2.1 Architectural model

The top-level block diagram of a reference DVB-T2 end-to-end chain is shown in Figure 9.35 for the Transport Stream case.

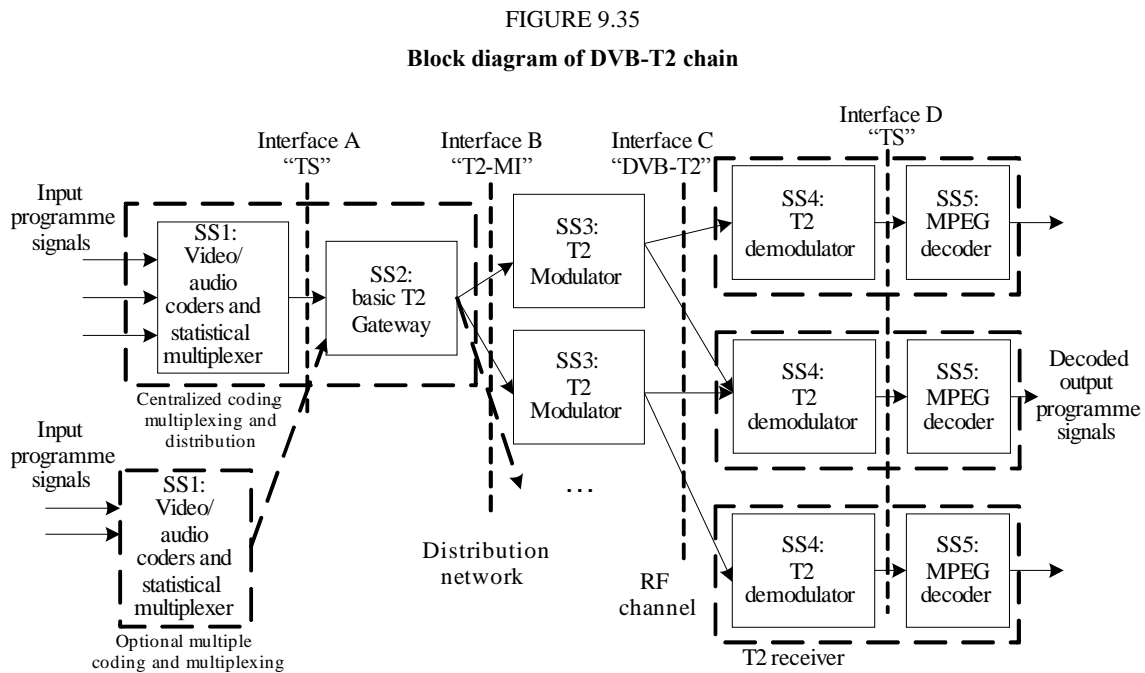

DTTB-09-35

The full DVB-T2 system can be divided into three basic sub-systems on the network side (SS1, SS2, SS3) and two sub-systems on the receiver side (SS4, SS5). Regarding interfaces, there are two corresponding interfaces on the network side (A and B), and one receiver-internal interface (D). The RF interface (C) is common to network and receiver.

On the network side the three sub-systems are:

- **SS1: Coding and multiplexing sub-system.** This includes generation of MPEG-2 Transport Streams and/or Generic Streams, e.g. GSE. For video services this includes video/audio encoding plus associated PSI/SI, or other Layer 2 signalling. Typically the video coding (and possibly audio coding) is performed with variable bit rate with a common control ensuring a total constant bit rate (excluding NULL packets) for all streams taken together. This subsystem is largely the same as for other DVB standards, but there are some T2-specific aspects of the coding and multiplexing. The coding and multiplexing sub-system interfaces to the T2-Gateway via the A interface (typically one or more MPEG-2 TSs over ASI) as specified in [9.8].

- **SS2: Basic T2-Gateway sub-system.** The input interface to this sub-system is exactly the same as that specified in [9.8], applicable both to the basic DVB-T2 physical layer and to the extension described in annex D of [9.8]. This includes functionality for Mode adaptation and Stream adaptation for DVB-T2, together with scheduling and capacity allocation:
 - The Basic T2-Gateway delivers at its output interface (B) a "T2-MI" stream: a sequence of T2-MI packets, each containing either a Baseband frame, IQ vector data for any auxiliary streams, or signalling information (L1 or SFN). The T2-MI stream contains all the information required to describe both the content and emission timing of T2-frames, and a single T2-MI stream is fed to one or more modulators in a network. The T2-MI interface format is defined in [9.150].
 - The operations performed by the Basic T2-Gateway include all those parts of the physical-layer specification [9.8] that are not completely prescriptive, such as scheduling and allocation. These need to be done centrally in an SFN, to ensure that the same signal is generated by all modulators.
- **SS3: DVB-T2 Modulator sub-system.** The DVB-T2 modulators use the Baseband frames and T2-frame assembly instructions carried in the incoming T2-MI stream to create DVB-T2 frames and emit them at the appropriate time for correct SFN synchronisation. The modulators interface to the receivers via the C interface (the transmitted DVB-T2 signal).

In the receiver the two sub-systems are:

- **SS4: DVB-T2 demodulator sub-system.** This sub-system receives an RF signal from one or (in an SFN) more transmitters in the network and (in the transport-stream case) outputs one transport stream. SS4 interfaces to SS5 via the D interface, a syntactically correct transport stream carrying usually one or more of the services as well as any common signalling data derived from the common PLP. The streams passing the B interface are identical to those passing the D interface.
- **SS5: Stream decoder sub-system.** This sub-system receives the transport stream and outputs decoded video and audio. Since interface D is a syntactically correct transport stream, this sub-system is essentially the same as for other DVB standards, except that some new L2-signalling elements³¹ have been defined for DVB-T2.

DVB-T2 Lite (known as ITU-R Digital Terrestrial Multimedia System T2) is based on the DVB-T2 standard, so this multimedia broadcasting system reuses terrestrial television broadcasting infrastructure based on an umbrella standard (ETSI EN 302 755 v.1.3.1 [9.8]).

The T2 Lite profile allows most of the flexibility of the DVB-T2 specification, but maximizes its effectiveness for mobile reception whilst minimizing the requirements for the receivers. It was designed so that only minimal changes were needed from an existing DVB-T2 modulator and demodulator to be able to support the new profile, which was intended to encourage its adoption by equipment manufacturers. The architectural model of T2-Lite thus corresponds to the architecture of the basic DVB-T2 system with some minimal limitations.

The infrastructure for terrestrial television and multimedia broadcasting based on Multimedia System T2 is depicted on Figure 9.36.

³¹ Layer 2 (L2) signalling is signalling via sub-stream for delivery of transport stream service information. Basic set of L2 service information was extended with DVB-T2 specific description information (T2 delivery-system descriptor). This descriptor provides the signalling for the co-existence of several Transport Streams within the same multiplex. Furthermore, it describes the geographical cells and the centre frequencies used for the transmission of the particular T2 system in the specific multiplex. Signalling is also included of multiple RF channels per cell in parallel; this is for future use and single-profile receivers are not expected to be able to receive such signals. The T2 delivery-system descriptor is docked to the NIT at the same position as the corresponding DVB-T descriptor was docked.

FIGURE 9.36
Simulcasting of DVB-T2 Base and T2 Lite profile signals

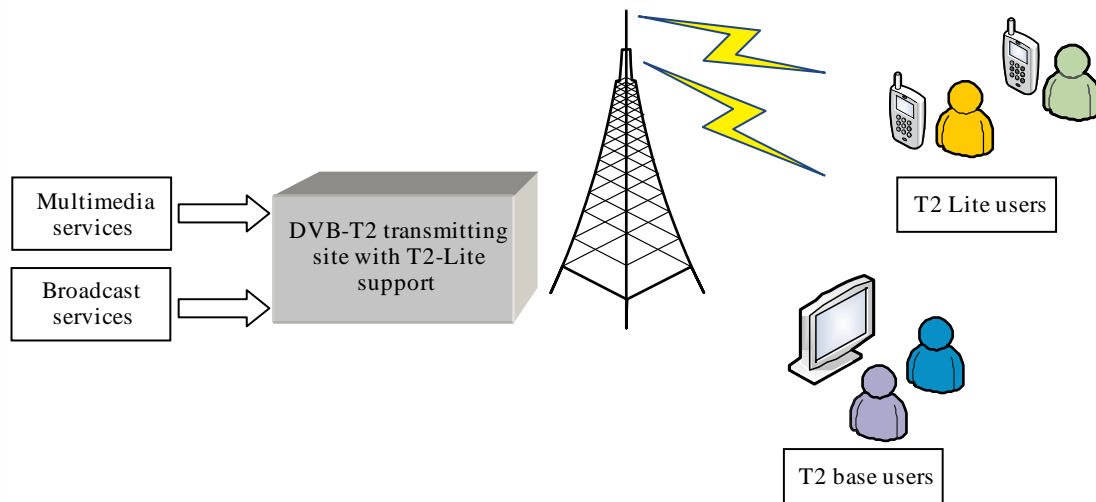

DTTB-09-36

The T2-Lite signal may be multiplexed together with a T2-base signal (and/or with other signals), with each signal being transmitted in its own FEF parts. Therefore, for example, a complete RF signal may be formed by combining a 32K FFT T2-base profile signal carrying HDTV services for fixed receivers using 256-QAM modulation, together with a T2-Lite profile signal using an 8K FFT and QPSK modulation to serve mobile receivers from the same network.

An example of the protocol stack used in DVB-T2 Base and T2-Lite systems is provided in Table 9.25. The basic protocol for audio-visual information transmission over physical media is MPEG-2 transport stream.

TABLE 9.25

Example of protocol stack for DVB-T2 Base & T2 Lite profile

Application (reproduction, recording etc)						
MPEG-4 AVC	MPEG-2 Video	MPEG Audio	AC-3, DTS	Subtitles, teletext	EPG, ESG	L1, SFN info, Aux data streams
				PSI	SI	
MPEG-TS				MPEG-2 section		
DVB Data Piping						
BB Frames, Future Extension Frames (FEFs)						
DVB-T2 data (Baseband stream)						
Physical layer of DVB-T2 (BCH, LDPC, M-QAM, OFDM etc)						

Additional to the basic elements of the DVB-T2 protocol, Future Extension Frames (FEFs) are included to complete the DVB-T2 protocol stack. This type of T2 frame is intended to allow upgrading of the DVB-T2 system to a variety of future applications (for an example, see Section 10.4). One such application is multimedia broadcasting (DVB-T2 Lite).

9.4.2.2 Key technologies in DVB-T2

The DVB-T2 system specification includes the following key features:

- The same basic modulation technique as DVB-T: Coded Orthogonal Frequency-Division Multiplexing (COFDM) with guard interval (GI), which provides a fundamentally resilient transmission system for the terrestrial channel.
- In order to make DVB-T2 also suitable for professional use, e.g. transmissions between radio cameras and mobile studios, a 10 MHz option is included; consumer receivers are not expected to support the 10 MHz mode. To allow DVB-T2 to be used in narrower RF channel assignments in e.g. band III and in the L-band, the bandwidth 1.712 MHz is also included. The 1.712 MHz bandwidth is intended for mobile services.
- Extended range of fast Fourier transform (FFT) sizes of OFDM, to increase the single-frequency-network (SFN) performance (e.g. to increase the SFN size) and, together with an increased range of GIs, to provide significantly improved bandwidth efficiency (due to the smaller guard interval at higher FFT sizes). The price to pay, however, is a reduced robustness in reception of the broadcast signal in a time-varying multipath channel.
- The same baseband framing and forward error correction (FEC) mechanisms included in DVB-S2 [9.151], adding the 256-quadrature amplitude modulation (QAM) constellation, to take full advantage of the efficiency of the error-correction technique, and introducing a concept called rotated constellation, which can significantly improve the system performance in frequency selective terrestrial channels.
- A method of transporting individual data services in separate logical channels, known as physical layer pipes (PLPs), within the physical layer, where the error-correction coding and interleaving are applied separately to each PLP. This allows for the implementation of service-specific robustness.
- A time interleaver of at least 70 ms for high-data-rate services, to provide increased immunity to impulsive interference.
- A very flexible frame structure, where the data can be either spread evenly across a whole frame for maximum time diversity or concentrated into bursts to allow power-saving techniques to be used in the receiver; the frame structure includes an efficient physical-layer signalling mechanism, called layer 1 (L1) signalling, which signals important parameters of the transmission system to the receiver. Note that special preamble symbol (the P1 symbol) needs to be decoded first, to derive, for example, the FFT size.
- Flexibility in frame building for new system applications thanks to Future Extension Frames (FEF). In such a way DVB-T2 Lite data transmission is implemented.
- Extended range of reference signals – scattered pilots (SPs) and continual pilots (CPs) – to allow an optimum choice to be selected for any given channel.
- An optional mechanism for transmit diversity, based on the Alamouti scheme, to improve reception in areas where the coverage from two transmitters overlaps.
- Two separate mechanisms for reducing the peak-to-average-power ratio (PAPR) of the transmitted signal.

Preambles for identification of T2 signal among other signals in frequency band, primary and secondary fast configuration of receiver path. For DVB-T2 Lite extension identification the special preamble is defined.

- Signalling is included to allow future backward-compatible standards to use parts of the T2 frame structure: time frequency slicing (TFS) to allow several radio frequency (RF) channels to be used together for increased capacity and frequency diversity; and optional parts of the frame whose content will be defined in the future (i.e. for DVB-NGH frames transmission), as the *future extension frame* (FEF) part.

DVB-NGH features are following:

- Multiple Antenna reception techniques (basic profile (SISO mode), MIMO profile, Hybrid profile (with satellite and terrestrial components like in DVB-SH), Hybrid MIMO profile (MIMO mode with combination of terrestrial and satellite transmissions).
- Modified FEC protection: specific LDPC code rates (3/15, 4/15, 5/15, 6/15, 7/15, 8/15, 9/15, 10/15) with shortened LDPC frame (16200 bits).
- Modified modulations: usage of QPSK, 16-QAM, 64-QAM and 256-QAM mappings with non-uniform constellations, 4D rotated constellations and Hierarchical modulation for local service insertion.
- Modified OFDM parameters: limited FFT sizes and specific pilot patterns.
- SFN variants: terrestrial SFN with eSFN (enhanced SFN) processing for decorrelation of the transmitted signal between multiple transmitters; Hybrid mode SFN with MIMO and non-MIMO processing.
- Extended bandwidths (for Hybrid MIMO mode): from 1.7 MHz to 20 MHz.

9.4.2.3 Physical layer in DVB-T2 Base and T2 Lite profiles

Transport stream to PLP mapping. Figure 9.37 shows the block diagram of a DVB-T2 transmitter. A DVB-T2 transmitter has the capability of handling multiple PLPs, to provide multiple services, while the DVB-T2 receiver is only required to decode a single data PLP together with its associated common PLP (if any). DVB-T2 allows each PLP to carry its own independent service transport stream (TS) or generic stream encapsulation (GSE) stream.

However, the DVB-T2 standard also defines a possible method to avoid transmitting the same information many times when handling multiple TSs: if multiple TSs share common packets (e.g. the event information table [EIT]), these can be removed from the TSs and mapped into the common PLP. The receiver will then merge the content of the common PLP and the user-selected data PLP to reconstruct the valid TS. The *TS/GSE to PLP* block of Figure 9.37 realizes the splitting and merging function, which ensures synchronization among the user-selected data PLPs and the common PLP, and provides full end-to-end TS transparency with improved bandwidth efficiency. The next *mode and stream adaptation* block maps the input stream into DVB-T2 blocks, with the compression of MPEG-2 null-packets and the insertion of Cyclic Redundancy Check (CRC) bits.

FIGURE 9.37

DVB-T2 block diagram

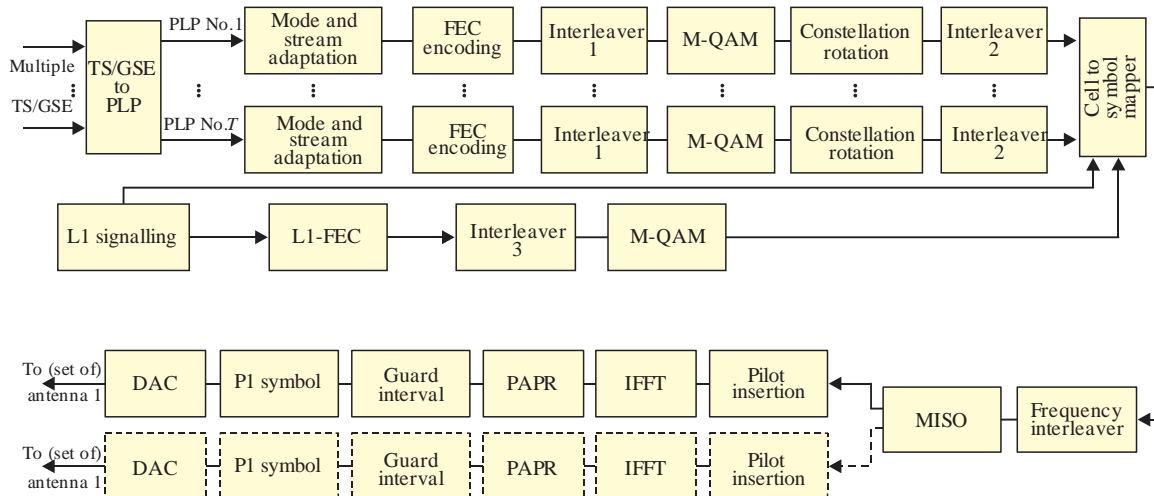

Error protection coding. Following the philosophy of the DVB standard family, forward error correction of DVB-T2 includes the BCH and a subset of the low density parity check (LDPC) codes of DVB-S2, with new bit interleaves. The target performance for the DVB systems (QEF) is defined to be “less than 1 uncorrected error event per program per transmission hour,” which for a 5 Mbit/s service means having a bit error rate (BER) on the order of 10^{-10} . The LDPC code alone cannot always guarantee this target performance, so a BCH code has been cascaded to the LDPC to avoid undetected errors at low BER while still having a high code rate.

Two block lengths are available: 64 800 bits or 16 200 bits. The performance of the short codes is some tenths of dB worse than normal codes, but allows for low-bit-rate applications with shorter latency. LDPC code rates available in DVB-T2 are a selection of the code rates of the DVB-S2 code: 1/2, 3/5, 2/3, 3/4, 4/5, and 5/6 are used for PLP protection; 1/4, for short code length only, is used in L1 signalling protection.

For rate 2/3, a new parity check matrix has been introduced replacing the DVB-S2 code, in order to improve the performance of the LDPC code at this rate.

The LDPC codes in DVB-T2 are irregular and the error protection level of each code bit is not uniform, but depends on the column weight of the parity check matrix. Hence, Bit Interleaved Coded Modulation (BICM) has been used to map the coded bits onto constellation symbols, by a cascade of an interleaver and a demultiplexer between the coder and the mapper, as shown in Figure 9.37.

Modulation Techniques. DVB-T2 uses coded OFDM (COFDM) [9.168] as used by the DVB-T, digital audio broadcasting (DAB), terrestrial integrated services digital broadcasting (ISDB-T), and Digital Radio Mondiale (DRM) broadcast standards, and by other radio systems such as IEEE 802.11a/n and the Long Term Evolution (LTE) of 3GPP. A wider range of OFDM parameters is offered than for DVB-T, while coding is also changed (as discussed above).

There are 1k, 2k, 4k, 8k, 16k, and 32k FFT sizes, and each subcarrier, in each symbol, is modulated using QAM constellations. A range of options is available for payload data: 4-, 16-, 64-, and 256-QAM. The combination of 256-QAM with the new LDPC error correction offers increased throughput with performance roughly comparable with 64-QAM in DVB-T.

Rotated constellations. The LDPC codes of DVB-T2 offer good performance in non-selective channels using a higher code rate than DVB-T – thus giving higher throughput. However, frequency selective channels need extra redundancy previously given by a lower-rate code. DVB-T2 also includes rotated constellation as an optional feature to improve performance even for very frequency selective channels. Rotating the constellation by a suitable angle means that every constellation point maps onto a different point on each of the I and Q axes. So a 16-QAM constellation has 16 different values for both I and Q (Figure 9.38).

On its own, this would not change anything. However, we contrive that the I and Q values derived from the rotated constellation are separated by cyclically delaying the Q before time and frequency interleaving.

The constellations actually transmitted after interleaving comprise unrelated I and Q values derived from different original rotated constellation (Figure 9.38). When the I and Q values are reunited after de-interleaving at the receiver, they will have been affected differently by any frequency selective fading. Suppose, as an extreme example, that one has been lost altogether. The surviving axis still contains information about all of the possible points – it is less reliable, but no longer a complete erasure.

FIGURE 9.38

Rotated constellation with cyclic Q delay. a) rotated 16-QAM before cyclic Q delay; b) rotated 16-QAM after cyclic Q delay, showing there are now 162 = 256 possible states

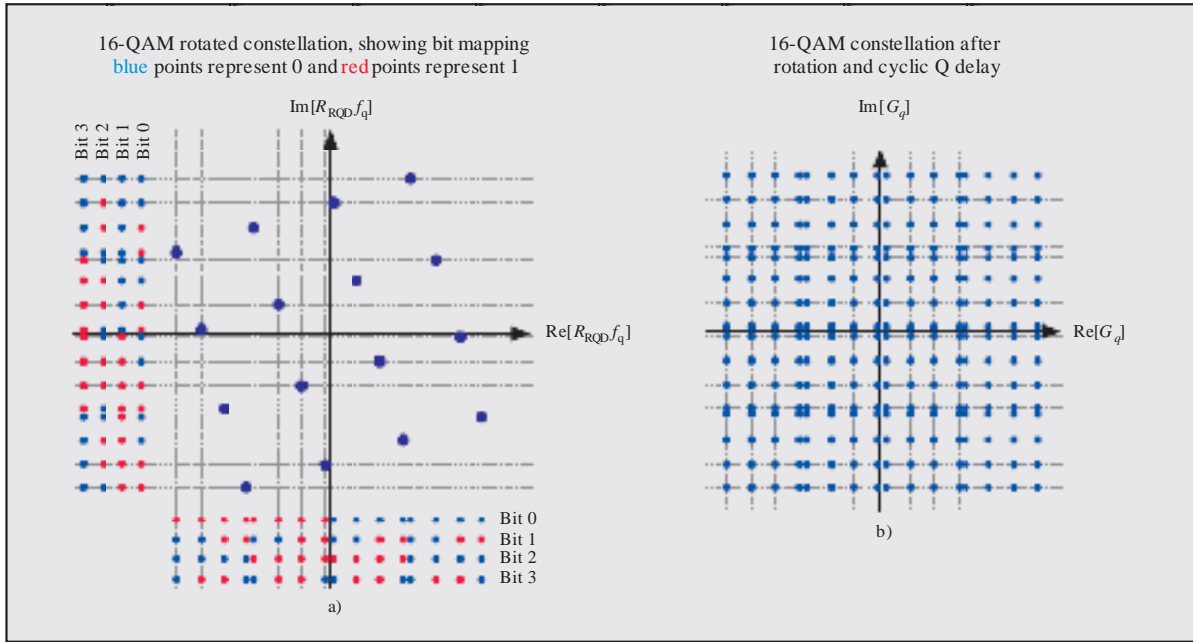

DTTB-09-38

Rotated constellation introduces further diversity as the same bit is mapped simultaneously in more subcarriers, thus achieving a higher degree of diversity. This would not be possible with denser constellations and lower code rate, as a single data bit would be mapped on a smaller number of subcarriers (due to the lower code rate). Simulations [9.169] show that rotated constellation provides up to 0.75 dB of advantage over conventional QAM on wireless channels at a very limited increase in implementation cost.

Scheduling. In order to offer service-specific robustness and optimize time-interleaving memory requirements, the DVB-T2 system can be described as a set of fully transparent PLPs, each one performing independent mode adaptation, FEC encoding, bitmapping onto constellation points (cells), and time interleaving. The scheduler/frame builder is a functional element that maps the data cells at the output of the time interleavers into OFDM symbols, also adding signalling information in order to construct DVB-T2 frames and super-frames (Figure 9.39).

FIGURE 9.39

DVB-T2 frame structure

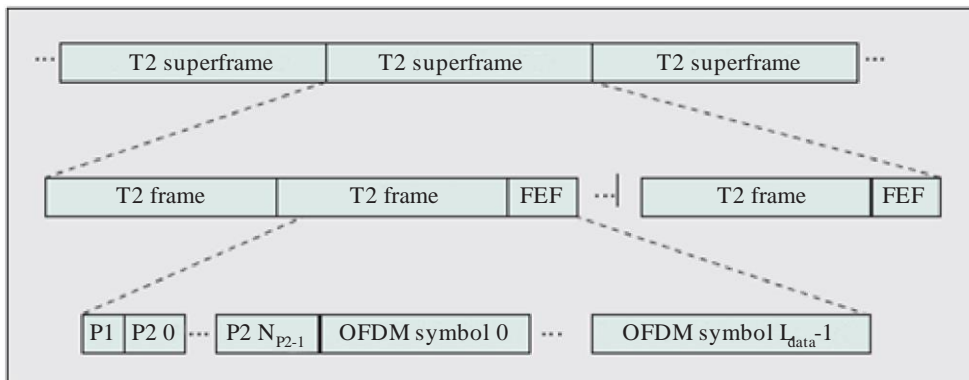

DTTB-09-39

Figure 9.40 shows a simplified example of how cells coming from different PLPs, each identified by a different colour, may be read from the time interleaving (TI) memories and mapped into OFDM symbols (vertical blocks); this is shown before the frequency interleaver is applied. The cell mapping strategy in time and frequency may be selected in a very flexible way. One possible target may be to achieve the maximum time diversity, thus spreading the cells from a PLP over all the OFDM symbols onto a frame, or even over multiple frames: to achieve this, the TI memory of a given PLP is split into several sub-slices, which are mapped in OFDM symbols alternated with the sub-slices of the other PLPs; this implies that, to receive the selected service, the receiver must operate continuously for all the OFDM symbols in a frame. A second target may be to obtain the maximum power saving in the receiver (e.g. for battery-powered portable devices) by switching the receiver on for only a small percentage of time: this can be achieved by concentrating cells of a PLP in time over a limited number of adjacent OFDM symbols, without sub-slicing, as shown in Figure 9.40. Note that the figure shows two DVB-T2 frames where the data rates of the PLPs are constant. If the data rates are changing, the size of the slices would change from frame to frame accordingly.

FIGURE 9.40

Different PLPs occupying different slices of individual modulation, code rate and time interleaving, two frames are shown



DITB-09-40

The DVB-T2 frame structure is shown in Figure 9.39. At the top level, the frame structure consists of superframes (maximum duration of 63.75 s when FEFs are not used, i.e. duration that is equivalent to 255 frames of 250 ms), which are divided into DVB-T2 frames; and these are further divided into OFDM symbols. The number of DVB-T2 frames per superframe is such that every data PLP has an integer number of interleaving frames per superframe. In turn, the superframe may optionally carry FEF parts, which are time periods left unused by DVB-T2 signal, allowing for other future services as yet undefined. The frame starts with one reference symbol called P1 and one or more reference symbols called P2 (discussed in more detail in the section on synchronization and channel estimation), followed by a configurable number of data symbols. The frame duration is on the order of 100 to 250 ms.

A data PLP does not have to be interleaved entirely within a single DVB-T2 frame, but may be spread across several frames.

The main purpose of the P2 symbols is to carry signalling data. As already said, the PLP throughput is time-variant; therefore, the position in time and frequency of the cells associated with a PLP changes frame by frame. Since the receiver must be able to extract at least the user selected data PLP and the common PLP (when present), it must be able to track the data cells' positions. The DVB-T2 system, even in case of static reception, may be affected by impulsive noise. Therefore, cell position signalling (the so called *dynamic L1* information) has been given particular design care in DVB-T2, by including various transmission mechanisms based on error correction and detection, and repetition. L1 signalling is in fact transmitted in each frame within the P2 symbol, but the information relevant to the next frame may also be embedded in the PLP data. It is also possible to repeat this information by L1 signalling both the current and next frames.

PAPR reduction. OFDM has the disadvantage that as the number of sub-carriers increases the peak-to-average-power ratio is high due to the increase of the crest factor caused, in turn, by the increased variation in QAM amplitudes, the increased number of boosted pilots and properties of OFDM signal itself (one of disadvantages of OFDM is high PAPR even in absence of pilots). This places high demands on the transmitter's power amplifier, especially with respect to its linearity. For mitigation, DVB-T2 includes two optional features that can reduce PAPR.

Active constellation extension (ACE) modifies some of the transmitted constellations by selectively moving their outer points to positions having greater amplitude [9.170]. ACE reduces PAPR without throughput loss, but is not used together with rotated constellation.

*Reserved-carrier PAPR reduction*³² sacrifices a small amount of throughput by reserving some subcarriers, which do not carry data [9.170]. They are used instead to carry arbitrary values, which permit the synthesis of a peak-cancelling waveform.

Synchronization and Channel Estimation. The DVB-T2 standard includes particular design solutions to ease the time and frequency synchronization of the receiver. The most apparent one is the use of a frame made of a preamble and a payload, as schematically depicted in Figure 9.41.

The preamble consists of a P1 symbol and a number of P2 symbols with the number depending on the chosen FFT size. For the 32k and the 16k sizes, there is only a single P2 symbol. For the 8k, 4k, 2k, and 1k sizes there are 2, 4, 8, and 16 P2 symbols, respectively. The payload follows the P2 symbols, although some of the data might already be carried within the P2 symbols, and consists of OFDM symbols of which subcarriers can be modulated by data or by known pilot values. The use of the preamble significantly improves some synchronization steps, and it further allows for a much wider choice of transmitter parameters without increasing the overall synchronization time.

The P1 symbol comprises an OFDM symbol with 1k subcarriers together with a special time domain repetition structure as depicted in Figure 9.41. The C part is a frequency shifted version of the first 542 samples of the OFDM symbol which forms the A part. The B part is the frequency shifted version of the last 482 samples of the A part. The frequency shift is equal to the subcarrier spacing of the OFDM symbol. Within the OFDM symbol, only 384 of the 1k subcarriers are differentially BPSK (DBPSK) modulated and used to transmit seven bits of information. The fixed P1 structure, together with the limited and highly protected signalling part, enables a fast scanning of the broadcast frequencies. The receiver can recognize the presence of a DVB-T2 transmission and store the key parameters (e.g. the FFT size or the presence of a FEF frame). The particular C → A → B structure is designed to improve the robustness of the P1 detection in the presence of the most challenging channels such as a zero dB echo with opposite phase. The detection of the P1 symbol is also used to derive an initial time and frequency reference.

³² “Reserved-carrier” is called “tone reservation” in the DVB-T2 standard.

FIGURE 9.41
P1 symbol format

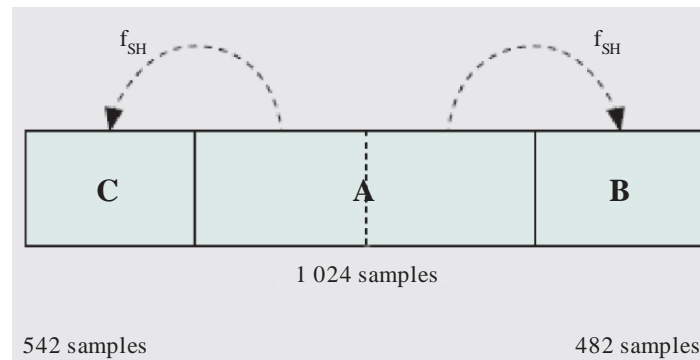

DTTB-09-41

The main role of the P2 symbol is carrying the L1-signalling, which can be quite large mainly because each PLP has its own transmission parameters. The L1-signalling is organized in an L1-pre signalling part (where, e.g. the frame length is signalled) and an L1-post signalling part. The protection of the bits of the L1-pre signalling is based on a BCH code followed by a punctured LDPC code. The choice of the LDPC code might seem odd given the short length of the codeword.

Nevertheless, it ensures no loss compared to a convolutional code with the same rate and does not require a Viterbi decoder, which would only be used to decode the L1-signalling. Another important role of the P2 symbol is to initiate the channel estimation process.

A DVB-T2 receiver needs to estimate the channel experienced by the transmitted waveform to properly retrieve the transmitted information. To this end, the DVB-T2 standard defines conventional scattered pilot sequences that modulate a set of equally spaced subcarriers. The main novelty introduced by DVB-T2 is that it supports eight different SP patterns. The guiding principle in the design has been to match the pilot distance to the inverse of the GI length. While the SP are mainly designed to provide a reliable channel estimate, the continual pilots, which are matched to the FFT size, provide a means for fine frequency synchronization and common phase error correction. The pilots in the P2 symbol are fixed and made to support the largest possible GI size, which is assumed to be acquired through conventional correlation-based methods. The pilot and data subcarriers' position in the P2 symbol are independent of other transmission parameters such as the bandwidth extension and the PAPR methods. Some of the SP patterns require a channel estimate to be formed from several symbols, and the P2 pilots help to initiate this process. This is particularly the case with a very efficient mode mainly meant for fixed rooftop reception. The DVB-T2 standard defines an option where very few pilots are transmitted in the payload, and the channel estimation is based on the initial estimate offered by the P2 symbol followed by a data-aided channel estimation in which the decoded bits are fed back and used to refine the channel estimate [9.171]. This approach is only possible if an initial complete estimate is available, so without P2 it would not be feasible. The different pilot distances also require adaptation of the pilot boosting factors (i.e. how much power is allocated to the pilots compared with the data). The DVB-T2 standard defines three boosting factors for SP and three for the CP.

The pilot values depend on the subcarrier index in the same way as for DVB-T. However, in DVB-T2, all the pilots (CP, SP, and P2) in each OFDM symbol are multiplied by plus or minus one according to a frame-level pseudo noise (PN) sequence, and thus also depend on the OFDM symbol index. Although DVB-SH adopts freewheeling techniques for symbol counting, this signature on pilots provides an alternative and more robust frame synchronization approach that can indicate the current OFDM position within the frame if the preamble was lost, for instance, in the event of strong impulsive noise. Moreover, synchronization algorithms can exploit this frame level sequence to estimate and track the clock, symbol, frequency, and frame synchronization. This is achieved with no influence on the quality of the channel estimation.

Multiple-Antenna techniques. The DVB-T standard allows simultaneous transmission on the same frequency of the same signal by multiple transmitters in order to implement a single-frequency network (SFN). By ensuring strict synchronization constraints, an SFN allows a simple network deployment where receivers see an equivalent channel obtained by the superposition of the channels relating to the multiple transmitters. However, when a receiver receives similar power levels from two transmitters, the channel frequency response will contain deep nulls due to destructive interference. For SFN with broadcasting stations equipped with a single antenna, by using a modified form of Alamouti [9.172] encoding, the new DVB-T2 standard provides an efficient means to exploit the presence of multiple transmitters. In other words, we obtain a distributed multiple-input single-output (MISO) system. In this configuration, the data on the two transmitters are not identical but closely related, avoiding destructive interference. As a result, the SFN coverage is improved³³.

In this case (described as 2×1 MISO), the pilots have to provide two independent channel estimations. Therefore, the number of pilots needs to be doubled. In this scenario the DVB-T2 standard uses the same pilot structure as for the single transmitter case (SISO), but half the corresponding size of the GI. The transmitters acting as antenna 1 use the exact same SISO pilot structure, while the transmitters acting as antenna 2 invert the pilots, modulating alternate pilot subcarriers.

DVB-T2 Lite physical layer. DVB T2-Lite essentially reuses the DVB-T2 physical and link layers with some limitations that minimize any changes in the existing equipment. Considering that it may be interpreted like profile of DVB-T2 basic specification and like standalone system intended for multimedia broadcasting. Detailed information on technical parameters and processing on transmitter/receiver side is provided in Recommendation ITU-R BT.1877 [9.34] and ETSI EN 302 755 [9.8]. The basic parameters for the physical and link layers are provided in Table 9.26.

TABLE 9.26

Transmission parameters for Multimedia System T2 (T2 Lite)

Parameters	Multimedia System T2
References	Rec. ITU-R BT.1877 and ETSI EN 302 755
Channel organization	Physical layer pipes (PLP) / Baseband frames / FEF frames
Channel bandwidths	1.7 MHz, 5 MHz, 6 MHz, 7 MHz, 8 MHz
Number of OFDM active subcarriers	1 705 (2k mode), 3 409 (4k mode), 6 817 (8k mode), 13 633 (16k mode)
Guard interval duration	1/128, 1/32, 1/16, 19/256, 1/8, 19/128, 1/4 of active symbol duration
Transmission unit (frame) duration	Flexible with possibility of changing on frame-by-frame basis. Max 250 ms
Time/frequency synchronization	P1 symbol/ Guard interval/ Pilot carriers
Modulation methods	QPSK, 16-QAM, 64-QAM with or without constellation rotation specific for each physical layer pipe
Coding and error correction methods	Combination of BCH code and LDPC code (rates 1/3, 2/5, 1/2, 3/5, 2/3, 3/4) with coded frame length limited to 16 200 bits. Correction capability from 10-12 errors
Net data rates	Max available input bit rate in case of transport stream is 4 Mbit/s
Spectrum efficiency (bit/s/Hz)	From 0.655 bit/s/Hz (QPSK 1/2) to 4.170 bit/s/Hz (64-QAM 7/8)
Stable and reliable reception and QoS control in various types of receiving environments	<ul style="list-style-type: none"> – Variable QoS and robustness – High mobility up to 300 km/h in 2k/4k/8k (QPSK 1/2)

³³ Considering SFN as MISO should be distinguished from the more classical case of MISO where transmission happens from a single transmit tower and the antennas being separated by a few meters only.

9.4.2.4 Performance of DVB-T2 system

The DVB-T2 standard provides a large set of transmission configurations. The choice of some parameters is also dictated by the network deployment, an example being the GI duration and SP (scattered pilot) pattern configuration, denoted as PP_x (Pilot Pattern *x*, where *x* is sequence number of pattern in ETSI EN 302 755 [9.8]), which are related to the maximum tolerable delay channel spread, including possible SFN transmissions³⁴. For other parameters, such as the code rate and constellation size, the choice is guided by noise level and channel statistics.

Table 9.27 shows the maximum throughput (in Mbit/s) that can be achieved by DVB-T2 for some typical parameter configurations.

TABLE 9.27
Achievable data rate (in Mbit/s) for some DVB-T2 configurations

FFT Size GI size Pilot Pattern	LDPC code rate	16-QAM	64-QAM	256-QAM
16k 1/128 PP7	3/5 2/3 3/4	18.07 20.11 22.62	27.11 30.17 33.93	36.14 40.21 45.24
32k 1/16 PP8	3/5 2/3 3/4	17.05 18.97 21.34	25.63 28.52 32.08	34.23 38.08 42.85
32k 1/128 PP7	3/5 2/3 3/4	18.07 20.11 22.62	27.02 30.06 33.82	36.14 40.21 45.24

Table 9.28 and Table 9.29 (taken from ETSI TS 102 831 [9.87]) give simulated performance, assuming perfect channel-estimation, perfect synchronization and without phase noise, of channel coding and modulation combinations.

These results are given for the Gaussian channel, Ricean channel (F1), Rayleigh channel (P1), and the 0 dB single-echo channel.

Results are given at a BER of 10^{-7} after LDPC, corresponding to approximately 10^{-11} after BCH.

To ensure reliable results, the simulations were run until the following two conditions had been fulfilled:

- minimum of 100 erroneous FEC blocks; and
- minimum of 1000 erroneous bits detected.

The DVB-T2 OFDM parameters used for these simulations were chosen to be as similar as possible to those for DVB-T. These parameters are as follows: the FFT size is 8k with a guard interval of 1/32, and the bandwidth is 8 MHz with normal carrier mode. Rotated constellations were used and PAPR techniques were not applied. The simulations assumed ideal conditions, i.e. ideal synchronisation and ideal channel estimation. In the simulations, the transmitted signal includes no pilots at all and the special symbols at both start (i.e. P1, P2) and end (i.e. Frame Closing Symbol) of the frame are not included. The values of $(C/N)_0$ should therefore be corrected for the FFT size and pilot pattern in use.

³⁴ Note that PP can be used quite flexibly. This is, for example, the case for PP2 or PP4 where there are fewer pilots but they are boosted.

TABLE 9.28

Required raw $(C/N)_0$ to achieve a BER = 1×10^{-7} after LDPC decoding
LDPC block length: 64800 bits

Constellation	Code rate	Spectral Efficiency (see Note 2)	Required $(C/N)_0$ (dB) for BER = 1×10^{-7} after LDPC decoding			
			Gaussian Channel (AWGN)	Ricean channel (F_1)	Rayleigh channel (P_1)	0 dB echo channel @ 90% GI
QPSK	1/2	0.99	1.0	1.2	2.0	1.7
QPSK	3/5	1.19	2.3	2.5	3.6	3.2
QPSK	2/3	1.33	3.1	3.4	4.9	4.5
QPSK	3/4	1.49	4.1	4.4	6.2	5.7
QPSK	4/5	1.59	4.7	5.1	7.1	6.6
QPSK	5/6	1.66	5.2	5.6	7.9	7.5
16-QAM	1/2	1.99	6.0	6.2	7.5	7.2
16-QAM	3/5	2.39	7.6	7.8	9.3	9.0
16-QAM	2/3	2.66	8.9	9.1	10.8	10.4
16-QAM	3/4	2.99	10.0	10.4	12.4	12.1
16-QAM	4/5	3.19	10.8	11.2	13.6	13.4
16-QAM	5/6	3.32	11.4	11.8	14.5	14.4
64-QAM	1/2	2.98	9.9	10.2	11.9	11.8
64-QAM	3/5	3.58	12.0	12.3	14.0	13.9
64-QAM	2/3	3.99	13.5	13.8	15.6	15.5
64-QAM	3/4	4.48	15.1	15.4	17.7	17.6
64-QAM	4/5	4.78	16.1	16.6	19.2	19.2
64-QAM	5/6	4.99	16.8	17.2	20.2	20.4
256-QAM	1/2	3.98	13.2	13.6	15.6	15.7
256-QAM	3/5	4.78	16.1	16.3	18.3	18.4
256-QAM	2/3	5.31	17.8	18.1	20.1	20.3
256-QAM	3/4	5.98	20.0	20.3	22.6	22.7
256-QAM	4/5	6.38	21.3	21.7	24.3	24.5
256-QAM	5/6	6.65	22.0	22.4	25.4	25.8

NOTE 1 – Figures in italics are approximate values.

NOTE 2 – Spectral efficiency does not take into account loss due to signalling / synchronization / sounding and Guard Interval.

NOTE 3 – The BER targets are discussed above.

NOTE 4 – The expected implementation loss due to real channel estimation needs to be added to the above figures. This value will be significantly less than the corresponding figure for DVB-T in some cases, due to better optimisation of the boosting and pattern densities for DVB-T2.

NOTE 5 – Entries shaded blue are results from a single implementation. All other results are confirmed by multiple implementations.

TABLE 9.29

Required raw $(C/N)_0$ to achieve a BER = 1×10^{-7} before BCH decoding.
LDPC block length: 16200 bits

Constellation	Code rate	Effective Code Rate	Required $(C/N)_0$ (dB) for BER = 1×10^{-7} after LPDC decoding				
			Spectral Efficiency (see Note 2)	Gaussian Channel (AWGN)	Ricean channel (F_1)	Rayleigh channel (P_1)	0 dB echo channel @ 90% GI
QPSK	1/2	4/9	0.87	0.7	0.9	2.0	1.6
QPSK	3/5	3/5	1.18	2.5	2.7	4.1	3.7
QPSK	2/3	2/3	1.31	3.4	3.6	5.3	4.8
QPSK	3/4	11/15	1.45	4.3	4.6	6.6	6.2
QPSK	4/5	7/9	1.53	4.9	5.3	7.4	7.0
QPSK	5/6	37/45	1.62	5.5	5.9	8.3	7.9
16-QAM	1/2	4/9	1.74	5.5	5.7	6.9	6.6
16-QAM	3/5	3/5	2.36	7.9	8.2	9.6	9.3
16-QAM	2/3	2/3	2.63	9.1	9.4	11.1	10.8
16-QAM	3/4	11/15	2.89	10.3	10.7	12.8	12.5
16-QAM	4/5	7/9	3.07	11.1	11.5	13.9	13.8
16-QAM	5/6	37/45	3.25	11.7	12.2	15.0	15.0
64-QAM	1/2	4/9	2.60	9.2	9.5	11.0	10.8
64-QAM	3/5	3/5	3.54	12.3	12.6	14.4	14.3
64-QAM	2/3	2/3	3.94	13.8	14.1	16.1	15.9
64-QAM	3/4	11/15	4.34	15.5	15.8	18.2	18.0
64-QAM	4/5	7/9	4.60	16.4	16.8	19.5	19.5
64-QAM	5/6	37/45	4.87	17.1	17.6	20.6	20.9
256-QAM	1/2	4/9	3.47	12.6	12.9	14.6	14.6
256-QAM	3/5	3/5	4.72	16.9	17.2	19.0	19.3
256-QAM	2/3	2/3	5.25	18.1	18.4	20.5	20.9
256-QAM	3/4	11/15	5.78	20.3	20.6	22.9	23.3
256-QAM	4/5	7/9	6.14	21.6	22.0	24.5	25.1
256-QAM	5/6	37/45	6.49	22.4	22.9	25.8	26.6

NOTE 1 – Figures in italics are approximate values.

NOTE 2 – Spectral efficiency does not take into account loss due to signalling / synchronization / sounding and Guard Interval.

NOTE 3 – The BER targets are discussed above.

NOTE 4 – The expected implementation loss due to real channel estimation needs to be added to the above figures. This value will be significantly less than the corresponding figure for DVB-T in some cases, due to better optimisation of the boosting and pattern densities for DVB-T2.

NOTE 5 – All the results in this table are from a single implementation and are therefore shaded blue.

The values of required (C/N) given in Tables 9.28 and 9.29 are raw and do not taken into account the reduction in data C/N resulting from the presence of boosted pilots, since this depends on the pilot pattern in use. Net values of C/N can be derived from the raw values (C/N)₀ by computing a correction factor Δ_{BP} such that :

$$\frac{C}{N} = \left(\frac{C}{N} \right)_0 + \Delta_{BP}$$

This correction factor is calculated by the following formula:

$$\Delta_{BP} = 10 \log_{10} \frac{(N_{data} + N_{NBP} + N_{BP} \cdot B_{BP} + N_{CP} B_{CP})}{N_{data} + N_{NBP} + N_{BP} + N_{CP}}$$

Where:

- N_{data} Number of data cells per OFDM symbol
- N_{NBP} Number of non-boosted pilots per OFDM symbol
- N_{BP} Number of boosted pilots (i.e. scattered and edge pilots) per OFDM symbol
- B_{BP} Power boost of boosted pilots relative to data cells, equal to A_{SP}^2
- N_{CP} Number of continual pilots per OFDM symbol
- B_{CP} Power boost of continual pilots relative to data cells, equal to A_{CP}^2 .

Note that the above formula is derived for the normal data symbols, but the P1, P2 and Frame Closing symbols are designed to have essentially the same power as the normal symbols (to within 0.1 dB) so the formula can be applied to the entire T2 frame.

The correction factor Δ_{BP} varies from 0.29 dB to 0.53 dB; values for each combination of FFT size and Scattered Pilot Pattern PP1-PP8 are given in Table 9.30.

TABLE 9.30
Correction factors Δ_{BP} for pilots (dB)

	PP1	PP2	PP3	PP4	PP5	PP6	PP7	PP8
1K	0.34	0.32	0.44	0.42	0.48		0.29	
2K	0.35	0.33	0.43	0.42	0.47		0.29	
4K	0.39	0.37	0.47	0.45	0.51		0.34	
8K	0.41	0.39	0.49	0.48	0.53		0.37	0.37
8K Ext	0.41	0.41	0.50	0.48	0.52		0.39	0.38
16K	0.41	0.38	0.49	0.47	0.52	0.49	0.33	0.35
16K Ext	0.42	0.38	0.49	0.47	0.52	0.49	0.34	0.35
32K		0.37	0.48	0.45		0.48	0.33	0.35
32K Ext		0.37	0.48	0.45		0.48	0.33	0.35

The simulations reported in the previous section were made under the assumption that the receiver has perfect, noiseless knowledge of the channel. This is an ideal which cannot be realised, but at least sets a clear single system-performance criterion. Receivers may use various practical implementations, the choice of which will be a compromise between two or more aspects of performance, and so results for a practical receiver would not set a clear performance criterion.

It is nevertheless of interest to consider how closely a practical receiver might approach the ideal results, and under what circumstances [9.87]. Then, it is useful to define a further correction term Δ_{RCE} so that net values of C/N required when using real, noisy channel estimation can be deduced from the tabulated simulation results:

$$\frac{C}{N} = \left[\frac{C}{N} \right]_0 + \Delta_{BP} + \Delta_{RCE}$$

where:

$$\begin{aligned} \Delta_{RCE} &= 10 \log_{10} \frac{SNR_{Data}}{SNR_{EQ-data}} \\ &\approx 10 \log_{10} \left(1 + \frac{f_{INT}}{B_{BP}} \right) \end{aligned}$$

Being $SNR_{EQ-data}$ the signal-to-noise ratio over the equalized data. B_{BP} is determined by the choice of pilot pattern, taking the values {16/9, 49/16, 49/9} respectively for patterns {PP1&2, PP3&4, PP5 to 8}. f_{INT} is a factor which depends on the interpolator used for the channel estimation. Indeed, strictly it varies from cell to cell according to their position within the two-dimensional scattered-pilot pattern, as each corresponds to a combination of particular phases of the frequency and temporal interpolators. Some form of averaging will be needed to give a representative single value, taking account of both frequency and temporal interpolation.

Examples of performance of DVB-T2 Lite profile is provided in Report ITU-R BT.2254 [9.115]. It is assumed that a DVB-T2 Lite mode shows the same sensitivity as the corresponding DVB-T2 Base mode. This implies that C/N values and protection ratios for DVB-T2 Base profile may be used for frequency and network planning in case of DVB-T2 Lite profile.

To date no simulation or measurement results are publicly available for the additional code rates 1/3 and 2/5. However, these code rates are also available in DVB-S2. Simulation results for DVB-S2 in a Gaussian channel are given in Table 9.31 and are compared with raw C/N for DVB-T2.

For the higher code rates the C/N figures are identical. Therefore, it can be expected that for the lower code rates in DVB-T2 Lite the figures in Table 9.31 apply.

TABLE 9.31

**Raw C/N for DVB-T2 and DVB-S2 for QPSK modes
(from [EN 302 755-V1.3.1] and [EN 302 307])**

Mode	Raw C/N (dB) DVB-T2	Raw C/N (dB) DVB-S2
QPSK 1/4	n/a	-2.4
QPSK 1/3	n/a	-1.2
QPSK 2/5	n/a	-0.3
QPSK 1/2	1.0	1.0
QPSK 3/5	2.2	2.2
QPSK 2/3	3.1	3.1
QPSK 3/4	4.1	4.0
QPSK 4/5	4.7	4.7
QPSK 5/6	5.2	5.2
QPSK 8/9	n/a	6.2
QPSK 9/10	n/a	6.4

9.4.2.5 Summary of system parameters

Table 9.32 defines characteristics of DVB-T2 and DVB-T2 Lite systems (see also Report ITU-R BT.2295-1 [9.43]).

TABLE 9.32

Key characteristics of DVB-T2 and DVB-T2 Lite systems

Characteristics	DVB-T2
Reception modes: – Fixed – Portable – Portable handheld – Mobile	+ + + +
Net data rates	7.5-50.5 Mbit/s
Spectrum efficiency (bit/s/Hz)	0.98-6.50
Single frequency networks	Supported
Broadcasting types: – sound – multimedia – TV	+ +
Transmission data/service types	Video, audio, data
Frequency bands	VHF, UHF
Channel bandwidth	a) 1.7 MHz b) 5 MHz c) 6 MHz d) 7 MHz e) 8 MHz f) 10 MHz 1
Used bandwidth (Note 2)	a) 1.52 MHz b) 4.75 MHz c) 5.71 MHz d) 6.66 MHz e) 7.61 MHz f) 9.51 MHz 1,2
Number of segments	Configurable
Number of subcarriers per segment (Note 2)	853 (1k mode) 1 705 (2k mode) 3 409 (4k mode) 6 817 (8k mode) 13 633 (16k mode) 27 265 (32k mode) 2, 3
Subcarrier spacing (Note 2)	a) 1 802 Hz (1k mode) 901 Hz (2k mode) 450 Hz (4k mode) 225 Hz (8k mode) 113 Hz (16k mode) 56 Hz (32k mode) b) 5 580 Hz (1k mode) 2 790 Hz (2k mode) 1 395 Hz (4k mode) 698 Hz (8k mode) 349 Hz (16k mode) 174 Hz (32k mode) c) 6 696 Hz (1k mode) 3 348 Hz (2k mode), 1 674 Hz (4k mode) 837 Hz (8k mode) 419 Hz (16k mode) 209 Hz (32k mode) d) 7 812 Hz (1k mode) 3 906 Hz (2k mode) 1 953 Hz (4k mode) 977 Hz (8k mode) 488 Hz (16k mode) 244 Hz (32k mode) e) 8 929 Hz (1k mode) 4 464 Hz (2k mode) 2 232 Hz (4k mode) 1 116 Hz (8k mode) 558 Hz (16k mode) 279 Hz (32k mode) f) 11 161 Hz (1k mode) 5 580 Hz (2k mode) 2 790 Hz (4k mode) 1 395 Hz (8k mode) 698 Hz (16k mode) 349 Hz (32k mode) 1,3

Table 9.32 (end)

Characteristics	DVB-T2
Active symbol duration (Note 2)	a) 554.99 μ s (1k), 1 109.98 μ s (2k), 2 219.97 μ s (4k), 4 439.94 μ s (8k) 8 879.87 μ s (16k) 17 759.75 μ s (32k) b) 179.2 μ s (1k), 358.4 μ s (2k), 716.8 μ s (4k), 1 433.6 μ s (8k), 2 867.2 μ s (16k), 5 734.4 μ s (32k) c) 149.3 μ s (1k), 298.67 μ s (2k), 597.33 μ s (4k), 1 194.67 μ s (8k), 2 389.33 μ s (16k), 4 778.67 μ s (32k) d) 128 μ s (1k), 256 μ s (2k), 512 μ s (4k), 1 024 μ s (8k), 2 048 μ s (16k), 4 096 μ s (32k) e) 112 μ s (1k), 224 μ s (2k), 448 μ s (4k), 896 μ s (8k), 1 792 μ s (16k), 3 584 μ s (32k) f) 89.6 μ s (1k), 179.2 μ s (2k), 358.4 μ s (4k), 716.8 μ s (8k), 1 433.6 μ s (16k), 2 867.2 μ s (32k) 1,3
Guard interval duration/ ratio	1/128, 1/32, 1/16, 19/256, 1/8, 19/128, 1/4
T2-Frame duration	Flexible with possibility of changing on frame-by-frame basis. Max 250 ms
Time/ frequency synchronization	P1 symbol/Guard interval/Pilot carriers
Modulation methods	QPSK, 16-QAM, 64-QAM, 256-QAM with or without constellation rotation specific for each physical layer pipe
Inner FEC	LDPC code with code rates 1/3, 2/5, 1/2, 3/5, 2/3, 3/4
Inner interleaving	Cell, time and frequency interleaving
Outer FEC	BCH (16 200, x, t), where x – depends on LDPC code rate. Error correction capability t = 12 errors
Outer interleaving	Bit (parity & column twist) interleaving
Data randomization/ energy dispersal	16 bit PRBS
Hierarchical transmission	–
Transmission parameter signalling	Preamble symbol P1

NOTE 1 – The 10 MHz configuration of DVB-T2 is only intended for professional applications and is not expected to be supported by domestic receivers.

NOTE 2 – The values in the DVB-T2 table apply to the normal carrier mode. An extended carrier mode is available for 8k, 16k and 32k modes.

NOTE 3 – A limited sub-set of modes shall be used for DVB-T2 Lite. The mode limitations apply to FFT size, pilot patterns and to the allowed combinations of these parameters and guard interval. The allowed set of FFT sizes for DVB-T2 Lite is restricted to 2k, 4k, 8k and 16k.

9.4.2.6 Link budget

Report ITU-R BT.2254 [9.115] provides values of C/N for the Gaussian channel, Rice and Rayleigh channel estimated with additional factors and thus defining “real life” ratios. For detailed information please see [9.115].

Some examples of the minimum receiver input signal levels defined in [9.115] are provided in Table 9.33 for 8 MHz and different C/N values.

TABLE 9.33

Minimum required input signal levels for 8 MHz versions and different C/N values

Frequency bands III, IV, V – 8 MHz channels Normal carrier mode: 1k, 2k, 4k, 8k, 16k, 32k modes					
Equivalent noise bandwidth B (MHz)	7.61	7.61	7.61	7.61	7.61
Receiver noise figure F (dB)	6	6	6	6	6
Receiver noise input power P_n (dBW)	-129.2	-129.2	-129.2	-129.2	-129.2
RF signal/noise ratio C/N (dB)	8.0	11.0	16.0	20.0	24.0
Min. receiver signal input power P_s min (dBW)	-121.7	-117.7	-113.7	-111.2	-108.2
Min. equivalent receiver input voltage, U_s min (dB μ V) 75 Ω	17.5	21.5	25.5	29.5	33.5

In defining coverage, it is indicated that due to the very rapid transition from near perfect to no reception at all, it is necessary that the minimum required signal level is achieved at a high percentage of locations. These percentages have been set at 95% for “good” and 70% for “acceptable” portable reception. For mobile reception the percentages defined were 99% and 90%, respectively. Considering that this clause is on DVB-T2 Lite, only three reception modes are analysed (see Table 9.34). Other variants are provided in Report ITU-R BT.2254 [9.115].

TABLE 9.34

Reception modes, example DVB-T2 variants, C/N values

Reception mode	Example DVB-T2 variant	C/N (dB)
Mobile reception/rural	16-QAM, FEC 1/2, 8k, PP1	10.2
Handheld portable outdoor reception (Class H-A)	16-QAM, FEC 1/2, 16k, PP3	9.8
Handheld mobile reception (Class H-D) (i.e. terminals are used within a moving vehicle)	16-QAM, FEC 1/2, 8k, PP2	10.2

The calculations are performed for two frequencies representing Band III (200 MHz) and Bands IV and V (650 MHz) and a bandwidth of 7 MHz in Band III and 8 MHz in Bands IV and V. For Band III the “mobile/rural” reception mode is calculated for the 1.7 MHz bandwidth and the “handheld class H-D” reception mode is calculated for both 1.7 MHz and 7 MHz bandwidth.

Suitable DVB-T2 variants are chosen for the reception modes. They are to be understood as examples for the respective reception modes, since the large number of DVB-T2 system variants always allows for a choice out of several possible variants.

The DVB-T2 variants indicated in Table 9.35 are examples for a possible choice of the variant. For each reception mode there are several DVB-T2 variants available with their respective bit rates. In addition, the choice of the guard interval affects the bit rate but does not change the required C/N . Therefore, in the tables, for the available net bit rate a range is given. Not all guard interval lengths are available for the chosen pilot pattern. If the latter is changed also the C/N may slightly change. Information is provided for mobile and handheld scenarios in Band IV/V. For obtaining information for other bands see Report ITU-R BT.2254 [9.115].

Table 9.35 shows two possible variants for each link budget for different required percentage location availability. These are differentiated by colour.

TABLE 9.35

Link Budget for DVB-T2 for mobile and handheld scenarios in Band IV/V

Parameters	Units	Mobile/rural	Handheld / portable outdoor	Handheld mobile Class H-D/ integrated antenna
Frequency	MHz	650	650	650
Minimum C/N required by system	dB	10.2	9.8	10.2
System variant (example)		16-QAM FEC 1/2, 8k, PP1 Extended	16-QAM FEC 1/2, 16k, PP3 Extended	16-QAM FEC 1/2, 8k, PP2 Extended
Bit rate (indicative values)	Mbit/s	11-14	12-15	11-14
Receiver noise figure	dB	6	6	6
Equivalent noise bandwidth	MHz	7.71	7.77	7.71
Receiver noise input power	dBW	-128.3	-131.6	-127.9
Min. receiver signal input power	dBW	-118.9	-119.3	-118.9
Min. equivalent receiver input voltage, 75 Ω	dB μ V	19.8	19.5	19.8
Feeder loss	dB	0	0	0
Antenna gain relative to half dipole	dB	0	-9.5	-9.5
Effective antenna aperture	dBm ²	-15.6	-25.1	-25.1
Min power flux-density at receiving location	dB(W/m ²)	-103.3	-94.2	-93.8
Min equivalent field strength at receiving location	dB(μ V/m)	42.5	51.6	52.0
Allowance for man-made noise	dB	0	0	0
Penetration loss (building or vehicle)	dB	0	0	8
Standard deviation of the penetration loss	dB	0	0	2
Diversity gain	dB	0	0	0
Location probability	%	90	70	90
Distribution factor		1.28	0.5244	1.28
Location deviation	dB	5.5	5.5	5.9
Location correction factor	dB	7.04	2.8842	7.552
Minimum median power flux-density at reception height; 50% time and 50% locations	dB(W/m ²)	-96.3	-91.3	-78.3
Minimum median equivalent field strength at reception height; 50% time and 50% locations	dB(μ V/m)	49.5	54.2	67.5
Location probability	%	99	95	99
Distribution factor		2.3263	1.6449	2.3263
Location deviation	dB	5.5	5.5	5.9
Location correction factor	dB	12.79465	9.04695	13.72517
Minimum median power flux-density at reception height; 50% time and 50% locations	dB(W/m ²)	-90.6	-85.2	-72.1
Minimum median equivalent field strength reception height; 50% time and 50% locations	dB(μ V/m)	55.2	60.6	73.7

9.4.2.7 Example of possible use of DVB-T2 system

The DVB-T2 system is designed to be highly flexible, allowing different trade-offs to be made in terms of capacity and ruggedness, as well as flexibility and overhead. For example, the system may be used in a very simple configuration to carry a few HDTV services within a single PLP, intended for fixed rooftop reception. In this case, some typical parameter choices might be:

- 32K FFT with 1/128 guard interval for an MFN configuration, which maximises the available capacity;
- 32K FFT with 19/128 guard interval for a national SFN configuration (providing a guard interval of 532 μ s); or
- 256-QAM with rotated constellations and code rate 3/5 or 2/3; the 256-QAM provides the maximum possible data capacity and is suitable for fixed rooftop reception, and the rotated constellations provide additional robustness for difficult reception conditions.

These configurations could provide approximately 36 Mbit/s to 40 Mbit/s for the MFN case, or 29 Mbit/s to 32 Mbit/s in the SFN case.

The use of the 32 K FFT will only be possible where the transmission channel is fairly static, and so for a network targeting portable and/or mobile reception, a lower FFT size and more robust constellation are likely to be used. For example, 8K FFT with 64-QAM and code rate 1/2 or 3/5 would provide good reception in more dynamic channels and with a lower carrier-to-noise ratio requirement. The penalty of course would be a lower available bit-rate, approximately 16 Mbit/s to 26 Mbit/s, depending on other parameter choices.

In order to understand under which channel conditions these rates can be achieved with quasi-error-free reception, we simulated two relevant cases, and compared the performance of DVB-T and DVB-T2 in a fixed Rician channel [9.36] with quasi-error-free reception (or equivalently a BER of 10^{-4} at the convolutional/LDPC decoder output). The first case is a typical SFN deployment of the DVB-T standard (adopted, e.g. in Italy), which includes 8K FFT, 1/4 GI, 64-QAM constellation, and 2/3 convolutional code rate.

Table 9.36 shows the comparison between DVB-T2 and DVB-T for a long guard interval (SFN) mode, with the same absolute guard interval in both cases. This provides a 67% increase in capacity for DVB-T2 compared to DVB-T. A longer guard interval mode is also available (nearly 20% increase), which would give improved SFN coverage for only a small loss of capacity (around 3%).

TABLE 9.36

Example of potential capacity increase of 67% for an SFN mode

	DVB-T mode	DVB-T2 mode
Modulation	64-QAM	256-QAM
FFT size	8K	32K
Guard Interval	1/4	1/16
FEC	2/3CC + RS	3/5LDPC + BCH
Scattered Pilots	8.3%	4.2%
Continual Pilots (see Note 1)	2.0%	0.39%
L1 overhead (see Note 2)	1.0%	0.65%
Carrier mode	Standard	Extended
Capacity	19.9 Mbit/s	33.2 Mbit/s

NOTE 1 – Includes only Continual Pilot cells which are not also Scattered Pilots.

NOTE 2 – TPS for DVB-T; L1-signalling, P1, and extra overhead in P2 and Frame Closing symbol for DVB-T2.

The second case (Table 9.37) shows the parameters used in the United Kingdom's multi-frequency network, which includes 2K FFT, 1/32 GI, 64-QAM, and 2/3 code rate, yielding 24.1 Mbit/s at an SNR of 18.9 dB in a fixed Rician channel for quasi-error-free conditions. Correspondingly, a DVB-T2 configuration with extended bandwidth, 32K FFT, 1/128 GI, 256 QAM, and an LDPC code rate of 3/5 provides a data rate of 36.1 Mbit/s, which is about 50 percent higher.

TABLE 9.37

Capacity increase of over 66% compared with DVB-T mode used in the UK

	UK DVB-T mode	UK DVB-T2 mode
Modulation	64-QAM	256-QAM
FFT size	2K	32K
Guard Interval	1/32	1/128
FEC	2/3CC + RS	2/3LDPC + BCH
Scattered Pilots	8.3%	1.0%
Continual Pilots (see Note 1)	2.0%	0.53%
L1 overhead (see Note 2)	1.0%	0.53%
Carrier mode	Standard	Extended
Capacity	24.1 Mbit/s	40.2 Mbit/s

NOTE 1 – Includes only Continual Pilot cells which are not also Scattered Pilots.

NOTE 2 – TPS for DVB-T; L1-signalling, P1 and extra P2 overhead for DVB-T2.

In both cases we observe that DVB-T2 allows for HDTV MPEG-4 AVC transmissions. With further developments in video compression methods, various countries are now trialling the possibility of UHDTV terrestrial broadcasting. The latest information of some of these trials is provided in Report ITU-R BT.2343 [9.116], and is summarised in Table 9.38.

TABLE 9.38
Summary of UHD-TV trials on terrestrial television networks (as of 2015)

Annex	Country	Transmitter site	Covering	ERP	DTT System	Channel bandwidth	Transmission mode	Multiplex capacity	Signal bit rate	Video encoding standard	Picture standard	Audio encoding standard	Frequency used
A1.1	Japan	Hitoiyoshi	City of Hitoiyoshi	140W(H) 135W(V)	ISDB-T ³⁵	6 MHz	32k $GI = 1/32$ 4096QAM, FEC 3/4 dual-polarized MIMO	91.8 Mbit/s	91 Mbit/s	MPEG-4 AVC/H.264	7 680×4 320p 59.94 frame/s 8 bits/pixel	MPEG-4 AAC 384 kbit/s	671 MHz (Ch 46 in Japan)
A1.2	Korea (Republic of) ³⁶	Kwan-Ak Mountain	South Metropolitan area of Seoul	36.7 kW	DVB-T2	6 MHz	32k, extended mode, $GI = 1/16$, PP4, 256 QAM, FEC 3/4, 4/5, 5/6	< 35.0 Mbit/s	Variable (some trials at 25–34 Mbit/s)	HEVC Main10 Level 5.1, Max 28 Mbit/s	3 840×2 160p 60 frames/s, 8 bits or 10 bits/pixel	MPEG-4 AAC-LC or Dolby AC-3, Max 5.1Ch, Max 600 kbit/s	713 MHz (Ch 54 in Korea)
				12.9 kW									701 MHz (Ch 52 in Korea)
		Nam Mountain	Central area of Seoul	40.0 kW	DVB-T2	6 MHz	32k, extended mode, $GI = 1/16$, PP4, 256 QAM, FEC 3/4, 4/5, 5/6	< 35.0 Mbit/s	Variable (some trials at 25–34 Mbit/s)	HEVC Main10 Level 5.1, Max 28 Mbit/s	3 840×2 160p 60 frames/s, 8 bits or 10 bits/pixel	MPEG-4 AAC-LC or Dolby AC-3, Max 5.1Ch, Max 600 kbit/s	707 MHz (Ch 53 in Korea)
				2.2 kW									713 MHz (Ch 54 in Korea)
A1.3	France	Eiffel Tower	City of Paris	1 kW	DVB-T2	8 MHz	32k, extended mode, $GI = 1/128$, 256QAM, FEC2/3, PP7	40.2 Mbit/s	Two programmes carried: one at 22.5 Mbit/s, one at 17.5 Mbit/s	HEVC	3 840×2 160p 50 frames/s 8 bits/pixel	HE-AAC 192 kbit/s	514 MHz (Ch26 in Region 1)
				8.3 kW									707 MHz (Ch 53 in Korea)
A1.4	Spain	ETSI Tele- comunicación	Ciudad Universitaria, Madrid	125W	DVB-T2	8 MHz	32k, extended mode, $GI = 1/128$, 64QAM, FEC5/6, PP7	36.72 Mbit/s	35 Mbit/s (other bit rates also tested)	HEVC	3 840×2 160p 50 frames/s 8 bits/pixel	E-AC-3 5.1	754 MHz (Ch56 in Region 1)

³⁵ Some parameters are extended from conventional ISDB-T system (System C of Recommendation ITU-R BT.1306).

³⁶ Details for Korea in Table correspond to Phase 3 of the trials. See Report ITU-R BT.2343 for more details of Phases 1 and 2.

TABLE 9.38 (end)

Annex	Country	Transmitter site	Covering	ERP	DTT System	Channel bandwidth	Transmission mode	Multiplex capacity	Signal bit rate	Video encoding standard	Picture standard	Audio encoding standard	Frequency used
A1.5	Sweden	Stockholm Nacka	City of Stockholm	35 kW	DVB-T2	8 MHz	32k, extended mode, $GI = 1/256$, 256QAM, FEC 3/5, PP4	31.7 Mbit/s	24 Mbit/s	HEVC	3 840×2 160p 29.97 frames/s 8 bits/pixel		618 MHz (Ch 39 in Region 1)
A1.6	UK	Crystal Palace	Greater London (serving over 4.5 Million households)	40 kW	DVB-T2	8 MHz	32k, extended mode, $GI = 1/128$, 256QAM, FEC 2/3, PP7	40.2 Mbit/s	Variable (some trials at 35 Mbit/s)	HEVC	Mixture of 3 840×2 160p 50 frames/s and 3 840×2 160p 59.94 frames/s Most of the trial at 8 bits/pixel, some at 10 bits/pixel		586 MHz (Ch 35 in Region 1)
		Winter Hill	North-west of England, including Manchester and Liverpool (serving 2.7 Million households)	22.5 kW		8 MHz							602 MHz (Ch 37 in Region 1)
		Black Hill	Central Scotland, including Glasgow and Edinburgh (serving 1 Million households)	39 kW		8 MHz							586 MHz (Ch 35 in Region 1)
A1.7	Brazil	Mt. Sumaré	Parts of Rio de Janeiro metropolitan area	660 W(H) 660 W(V)	ISDB-T ¹	6 MHz	32k $GI = 1/32$ 4096QAM, FEC 3/4 dual-polarized MIMO	91.8 Mb/s	HEVC	7 680×4 320p 59.94 frame/s 10 bits/pixel	MPEG-4 AAC 1.48 Mb/s	569 MHz (Ch 30 in Brazil)	

 GI = guard intervals

The provision of stationary and mobile services in the same DVB-T2 Lite multiplex is limited by the fact that the FFT mode and the pilot pattern cannot be adjusted within the same T2 Lite signal. Stationary services should be generally transmitted with large FFTs and sparse pilot patterns in order to achieve a high spectral efficiency in stationary channels. On the other hand, reception in mobile scenarios requires the utilization of smaller FFTs and more dense pilot patterns to follow the rapid variations in the time and frequency domain, and to cope with the ICI that is caused by the Doppler spread.

To solve this problem, T2-Lite signals can be transmitted in the FEF parts of a T2 multiplex. In this manner, the T2-Lite signal can be optimized in terms of FFT mode and pilot pattern for high robustness in mobile scenarios (e.g. 8k FFT and PP1), whereas the rest of the multiplex can be configured for high throughput in stationary channels (e.g. 32k and PP7). For example, it would be possible to dedicate 20% of the transmission time to T2-Lite by alternating T2-Lite frames of 50 ms with T2 frames of 200 ms. Assuming that the T2-Lite signal is transmitted with 8K FFT mode (with extended carrier mode), QPSK 1/2 and pilot pattern PP1, the total capacity for T2-Lite services is 1.5 Mbit/s per channel (8 MHz bandwidth). This would allow up to 4 services at 375 kbit/s to be carried in the T2-Lite signal.

It should be pointed out that a T2-Lite signal can also be transmitted as a stand-alone signal that occupies an entire frequency channel. For the same example as before, the total capacity for T2-Lite services is 7.5 Mbit/s, which would allow up to 20 services at 375 kbit/s to be transmitted in the same frequency channel. T2-Lite is also very well suited for the provision of digital radio services. The utilization of code rates below 1/2 can provide good coverage levels with a limited amount of network infrastructure, whilst T2-Lite-only receivers aimed at portable and mobile reception can be implemented with very low complexity. For example, by using 10% of the transmission time for T2-Lite in a combined T2/T2-Lite multiplex it is possible to accommodate about 18 radio services at 64 kbit/s with HE-AAC v2.

9.4.2.8 Example of a DVB-T2 Lite Trial

An example of the possible use of the DVB-T2 Lite system was demonstrated by *BBC R&D in July 2011*. *The results of the trial are highlighted in “DVB-T2 Lite profile tech standard approved: Transmissions are go” by Keren Greene [9.117]. The trial was implemented as described below.*

On 7 July 2011, *BBC engineers* began transmissions of DVB-T2-Lite from the roof of BBC R&D’s South Lab in West London.

The evaluation is being carried out on UHF channel 53 (730 MHz) and is being carried out under a test and development transmission license issued by Ofcom. This is entirely separate from the BBC’s on-air DTTB service. For this technical trial of T2-Lite, *engineers* have combined an HD multiplex intended for reception on fixed receivers with a more robust mobile service which could be television, radio or data or any combination of these. In the UK the currently used DVB-T2 mode (see Table 9.37) gives a bit-rate of 40.21 Mbit/sec in an 8 MHz channel. In this technical trial, the same mode for the HD part of the multiplex was used but with the addition of Future Extension Frames (FEFs) containing the mobile service. The HD part of the multiplex consists of a DVB-T2 frame which is 216.9 ms in duration followed by a FEF of 44.6 ms.

The mobile part of the service was transmitted in a more robust mode with a smaller FFT size (8k 1/32 QPSK 1/2) with L_DATA = 46. This gives a bit-rate of 1.02 Mbit/s for the mobile service.

9.4.2.9 Example of DVB-T2 Lite Implementation

On 25 February 2016, the Indian public broadcaster Doordarshan launched a free-to-air DVB-T2 Lite mobile TV service in 16 cities, aimed at the increasing number of smartphones in India. The service was officially launched in Delhi, Mumbai, Kolkata and Chennai, Guwahati, Patna, Ranchi, Cuttack, Lucknow, Jalandhar, Raipur, Indore, Aurangabad, Bhopal, Bangalore and Ahmedabad. The service can be received in and around these cities using DVB-T2/Wi-Fi dongles in PCs, laptops, and OTG³⁷-enabled smartphones and tablets as well as on integrated digital TV sets with DVB-T2 tuners. While iDTV’s are available from traditional TV manufacturers, the dongles are also available on online shopping sites like Flipkart, Ebay, Snapdeal, etc., the Doordarshan statement added. Currently DD National, DD News, DD Bharati, DD Sports, DD Regional/DD Kisan are being relayed [9.72].

³⁷ “On The Go”, used with USB in conjunction with smartphones and tablets.

9.5 ISDB-T

ISDB-T (Integrated Services Digital Broadcasting – Terrestrial) for digital terrestrial television broadcasting system was developed in 2000 and included in [9.33] as System C. It is a multi-carrier system with RF band segmentation.

The ISDB-T system is designed to provide reliable high-quality video, sound, and data broadcasting not only for fixed receivers but also for mobile receivers (see Figure 9.42). The system is rugged because it uses OFDM modulation, two-dimensional (time- and frequency-domain) interleaving, and concatenated error-correction codes. Its Band-Segmented Transmission OFDM (BST-OFDM) consists of 13 OFDM segments. The system has a wide variety of transmission parameters for choosing the carrier modulation scheme, the coding rate of the inner error-correcting code, the length of time interleaving, etc. Some of the carriers are assigned to control carriers, called transmission and multiplexing configuration control (TMCC) carriers, which transmit information on the transmission parameters. ISDB-T supports hierarchical transmission of up to three layers. Transmission parameters can be set individually for the layers, each of which consists of several segments. The system was specifically designed to provide flexibility, expandability, and commonality/interoperability for multimedia broadcasting.

FIGURE 9.42
ISDB-T Service

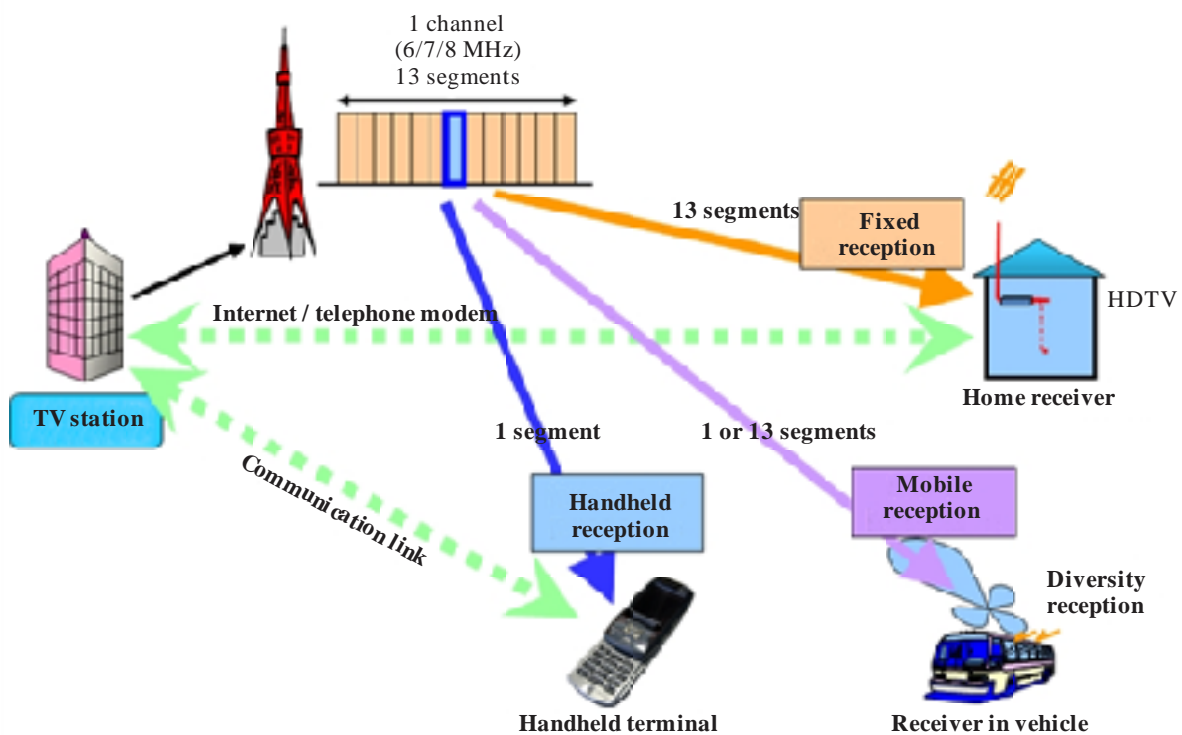

DTTB-09-42

The ISDB extension for terrestrial multimedia broadcasting, designed for providing real-time broadcasting services such as sound or video programs with various associated data, interactive broadcasting, and filecasting, is defined as ITU-R Multimedia System F. In fact, this multimedia system is an enhanced ISDB-T/T_{SB}-based³⁸ multimedia broadcasting system. The physical layer specification of the system is described in [9.33] as System C and in Recommendation ITU-R BS.1114 [9.38] as Digital System F (also known as ISDB-T_{SB}). The system overview, multimedia, and data applications are described in [9.35]. Other useful references on ISDB system are [9.134-9.139].

³⁸ ISDB-T_{SB} is a sound broadcasting system.

The physical layer of the ISDB-T multimedia broadcasting system has similarities to the ISDB-T family, i.e. the ISDB-T one-segment variant, ISDB-T_{SB} and ISDB-T. The ISDB-T multimedia broadcasting system can use different ISDB-T segment numbers and configurations. The basic compositions of ISDB-T multimedia broadcasting system are shown in Figure 9.43.

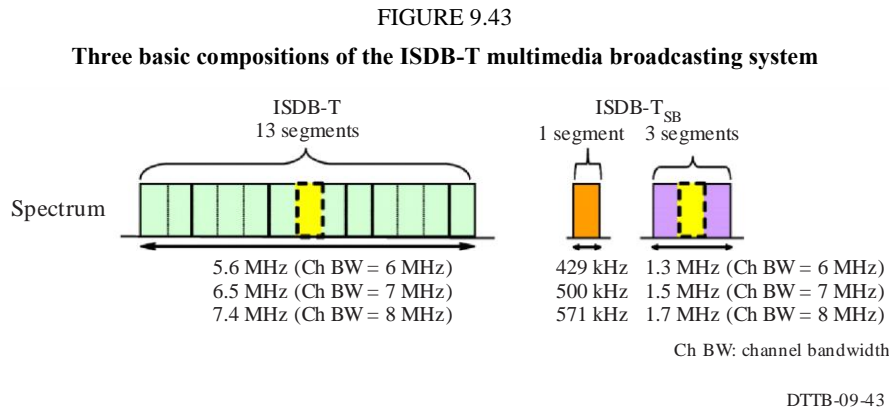

This system uses MPEG-2 for encapsulating data streams, which means that various digital content (such as video, sound, text, still pictures, and other data) can be transmitted simultaneously. It has commonality and interoperability with other ISDB systems using MPEG-2, such as ISDB-S, ISDB-C, ISDB-T_{SB}, and ISDB-Tmm.

9.5.1 Architectural model and protocol stack model

The ISDB-T functional block diagram is shown in Figure 9.44. ISDB-T has a wide variety of transmission parameters. The TS Re-Mux controls the number of TS packets sent to the RS coder by adding Null TS packets independently of the input number of the TS packets.

The system has up to three transmission layers with different levels of robustness by changing the modulation method, the coding rate of the convolutional code, etc. on each layer. A powerful error correction code called the concatenated code of convolutional coding/Viterbi decoding and Reed-Solomon (RS) coding/decoding, is used.

ISDB-T uses four types of interleaving: byte, bit, frequency, and time interleaving. These interleaving technologies are described in section 9.5.3.

FIGURE 9.44
ISDB-T Functional Block Diagram

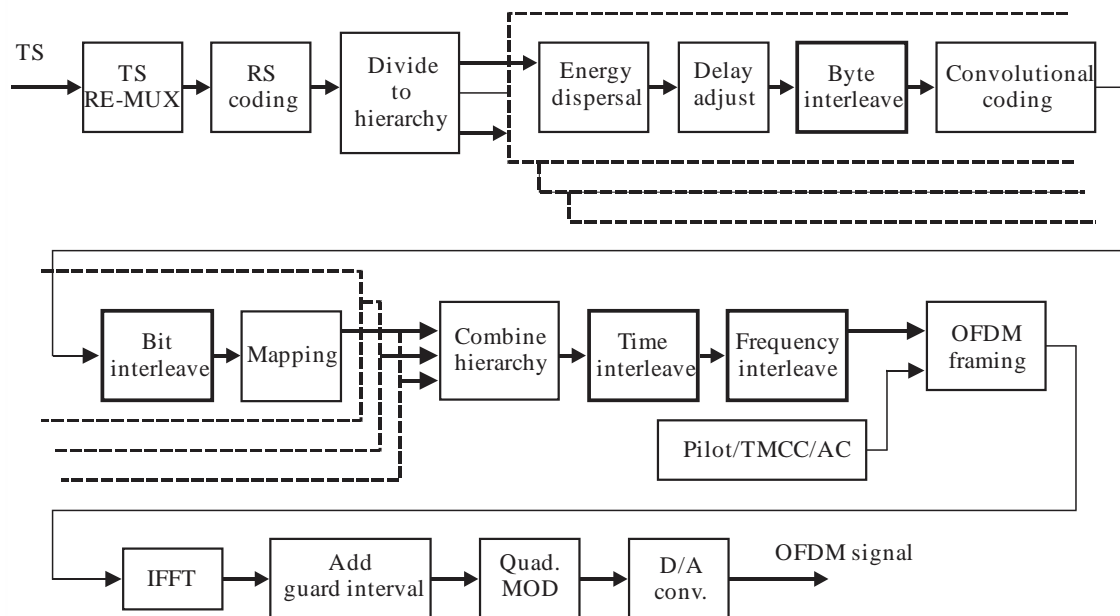

DTTB-09-44

The system has three transmission modes (Modes 1, 2, and 3) to enable the use of a wide range of transmitting frequencies, and it has four options for guard-interval length to enable better design of SFNs.

A typical ISDB-T multimedia broadcasting system is comprised of three subsystems: the Broadcast system, the Interactive broadcast system and the receivers (Figure 9.45). The broadcast system has a Broadcast Schedule/Management system, a Real-time broadcast system and a filecast system. The Real-time broadcasting signal and the filecasting signal are multiplexed and transmitted at the same time. Typical types of receivers are cell phones, music players, car navigation systems, digital photo frames and so on. The Interactive broadcast system has a Billing/Access Control system and a Streaming/Download system. The Streaming/Download system can also complement data missing from the mobile communication channel, which was not able to be received by broadcast channel.

FIGURE 9.45
Typical ISDB-T multimedia system architecture

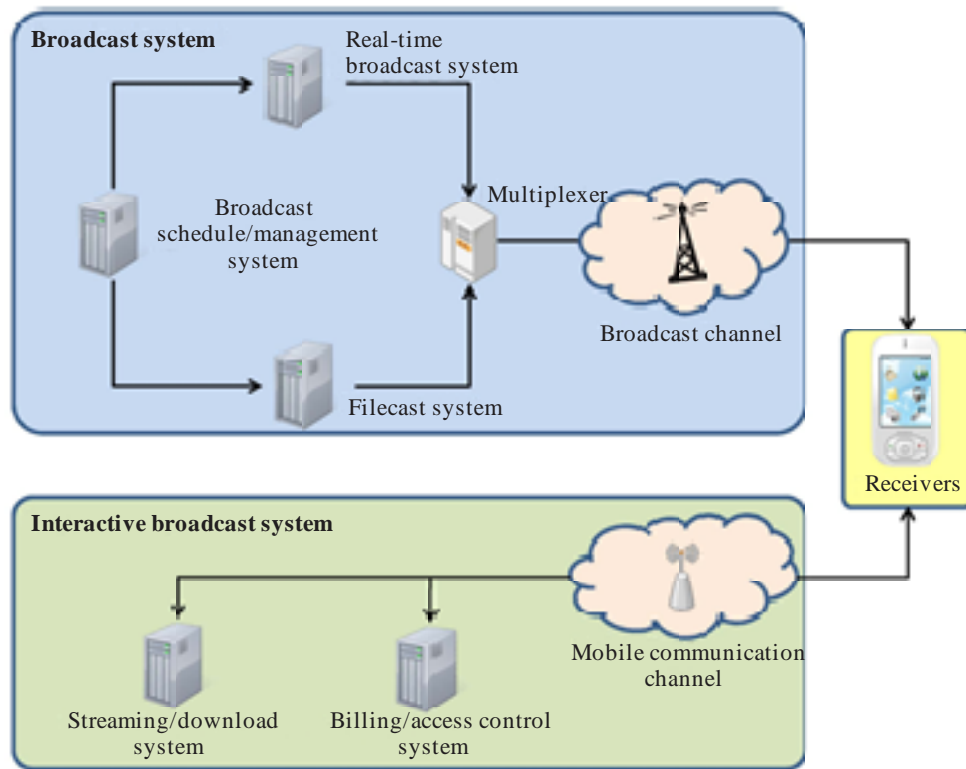

DTTB-09-45

The ISDB-T multimedia broadcasting system uses essentially the same multiplexing architecture as the rest of the ISDB-T family, that is, MPEG-2 Systems (see [9.6, 9.7]). In this layer, real-time broadcast contents and/or filecast content are multiplexed and transported.

Figure 9.46 shows the protocol stack for the ISDB-T multimedia broadcasting system. The real-time broadcast content is delivered under the same protocol as the existing ISDB-T family. Filecast content is transported by either the Internet Protocol (IP) over MPEG-2 TS or the DSM-CC section of the MPEG-2 TS.

FIGURE 9.46
Protocol stack of ISDB-T multimedia broadcasting system

IP-based application	Filecasting (1)		Real-time broadcasting	
	FLUTE/AL-FEC	Section (including DSM-CC)	PES	
UDP/IP				
ROHC or Recommendation ITU-R BT.1869				
ULE				
MPEG-2 TS				
Physical layer				

NOTE 1: Filecasting is supported by Multimedia System F (see [9.35])

DTTB-09-46

Figure 9.47 shows the transmission sequence of filecast content transported through IP. Any sort of filecast content, such as audiovisual clips, e-books, and newspapers, is divided into fixed-length packets with additional forward error correction (FEC) packets for file delivery over unidirectional transport (FLUTE) protocol as specified in RFC 3926 (the IP multicast scheme of 3GPP and 3GPP2) [9.39]. After the IP header redundancy is removed with either ROHC U-mode (RFC 3095, [9.40]) or the header compression scheme described in Recommendation ITU-R BT.1869 [9.2], the MPEG-2 TS packets are made with unidirectional lightweight encapsulation (ULE), as specified in RFC 4326 [9.41].

FIGURE 9.47
Transmission sequence of filecasting through IP

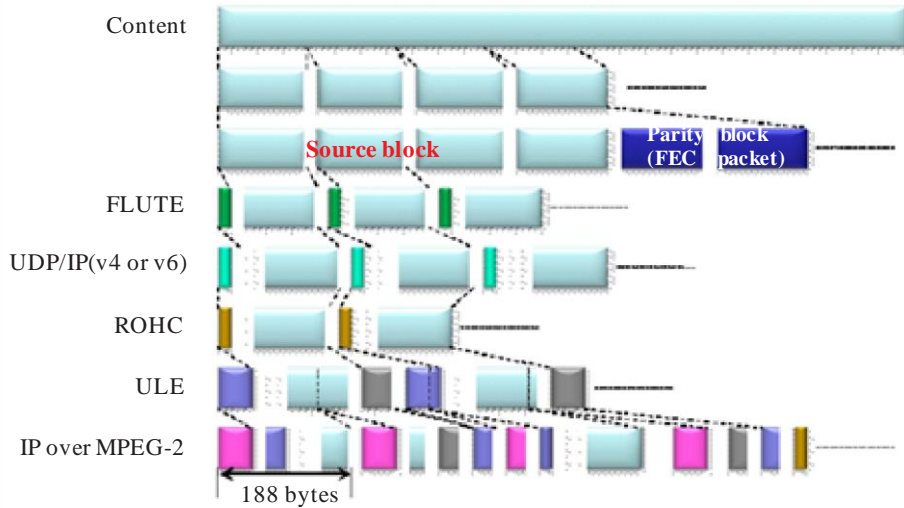

DTTB-09-47

Figure 9.48 shows the transmission sequence of filecast content transported through the DSM-CC section of an MPEG-2 TS. Download data block messages constructed from the required content are transported in the form of DSM-CC sections.

FIGURE 9.48
Transmission sequence of filecasting through DSM-CC sections

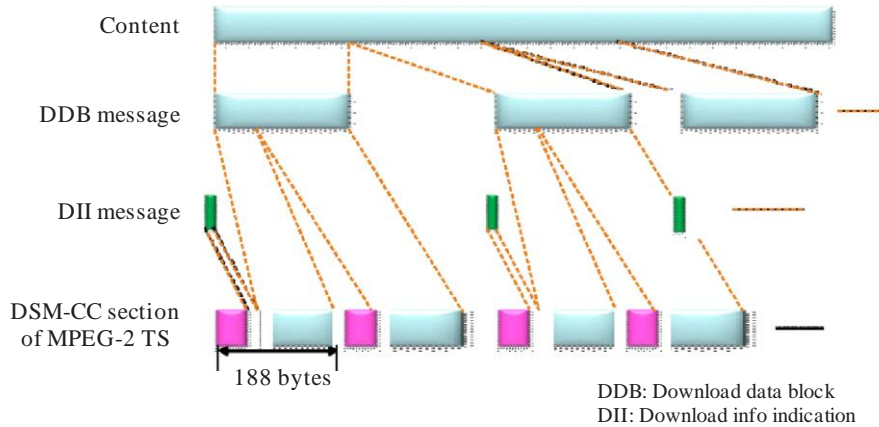

DDB: Download data block
DII: Download info indication

DTTB-09-48

9.5.2 Key technologies of ISDB-T and its multimedia broadcasting extension

Band-segmented transmission. The ISDB-T system uses OFDM modulation with radio-frequency band segmentation, BST-OFDM. The ISDB-T system consists of 13 OFDM segments, each of which has a bandwidth of $B/14$ MHz (B being the bandwidth of a terrestrial TV channel, i.e. 6, 7, or 8 MHz depending on the region), so one segment occupies a bandwidth of either 6/14 MHz (428.57 kHz), 7/14 MHz (500 kHz), or 8/14 MHz (571.29 kHz). One or more segments form a segment group. The transmission parameters of the modulation scheme of the OFDM carriers, the coding rates of the inner error correcting code, and the length of the time interleaving can be independently specified for each segment group. A segment group is the basic unit for delivering broadcast services.

Combinations of segment blocks. The number of segments of the ISDB-T multimedia broadcasting system can be chosen in accordance with the application and available bandwidth. The spectrum is formed by combining 1-segment, 3-segment, and/or 13-segment basic compositions without guard bands. Figure 9.49 shows transmission spectrum examples combining several segment blocks.

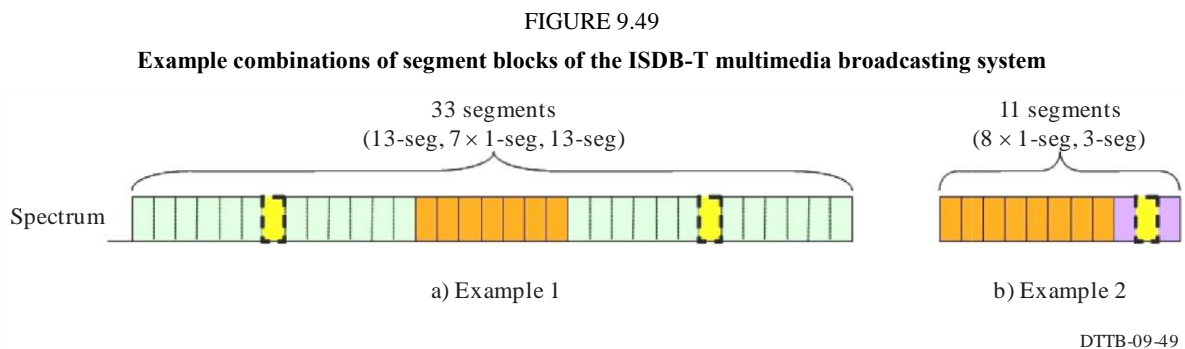

Hierarchical transmission and partial reception. The system supports hierarchical transmission of up to three layers (A, B, and C). The transmission parameters can be set in each of these layers. ISDB-T consists of 13 segments, and these segments are divided and assigned to the layers. Each layer has 1 to 13 segments, but the total number of segments for all layers is always 13. For example, when a broadcaster would like to provide a one-segment service for handheld receivers, the centre segment can be assigned to Layer A, and the other 12 segments can be assigned to Layer B or Layers B and C. In cases like this, handheld receivers can receive the centre segment only partially. This is called partial reception and means that a receiver can only pick out part of the transmission bandwidth. Partial reception reduces a handheld receiver's power consumption because it uses a low system clock frequency.

Interleaving technology. Four kinds of interleaving technology are used:

- The byte interleaver is located between the outer and inner coders. It randomizes the burst error of the Viterbi decoder's output.
- The bit interleaver is located between the convolutional coding and the mapping. It randomizes the symbol error of the constellation before Viterbi decoding.
- The time interleaver is located at the output of the mapping. It randomizes the burst error of the time domain, which is mainly caused by impulse noise and fading during mobile/portable reception.
- The frequency interleaver is located at the output of the time interleaver. It randomizes the burst error of the frequency domain, which is mainly caused by multi-path interference, carrier interference, etc.

MPEG-2 systems. The system uses MPEG-2 Systems to encapsulate data streams, which makes it possible to simultaneously transmit various forms of digital content, including sound, text, and still pictures. It has commonality and interoperability with other systems that use MPEG-2 Systems, such as ISDB-S, ISDB-C, ISDB-T_{SB}, and ISDB-T_{mm}. In Japan, the system uses MPEG-2 video coding and MPEG-2 advanced audio coding (AAC) for main TV programs and MPEG-4 advanced video coding (MPEG-4 AVC) for the One-Seg service. In South America, on the other hand, the system uses MPEG-4 AVC and MPEG-4 AAC for main TV programs.

Diversity reception for ISDB-T. For testing the Japan Broadcast Corporation (NHK) has been developing a prototype 4-branch diversity receiver base on maximal ratio combining (MRC) for each carrier. Field experiments were conducted in the Nagoya area to compare the coverage of digital terrestrial HDTV broadcasting for mobile and fixed reception with a diversity receiver. Evaluated at a reception rate of 95%, mobile reception of HDTV was indeed feasible at a fixed reception contour of more than 75 dB μ V/m for 4-branch reception and more than 80 dB μ V/m for 2-branch reception. The results obtained using a mobile vehicle showed significant attenuation of the received signal as compared to those using fixed reception. This was because mobile reception antennas were three metres above the ground while the fixed reception antennas were ten metres high; direct waves to the mobile reception antennas were far more likely to be blocked. The received field strength of mobile reception was reduced by as much as 15 dB as compared to the calculated field strength of fixed reception. For more details see Report ITU-R BT.2139 [9.74].

9.5.3 Physical and link layers of ISDB-T

The ISDB family uses MPEG-2 systems for multiplexing as a link layer, which means it has a common framed transport stream interface. For the physical layer, modulation and error correction are different depending on the transmission media. ISDB-T adopts a segmented OFDM and concatenated error correction coding of a convolutional code and the Reed-Solomon code. For source coding, the ISDB family adopts the same source coding.

The physical layer of the ISDB-T multimedia broadcasting system has affinity with the ISDB-T family, i.e. ISDB-T one-segment, ISDB-T_{SB}, and ISDB-T. The system has flexibility in its usage of segments. As shown in Figure 9.49, the spectrum for multimedia broadcasting can be most efficiently used by combining some 13-segment, 3-segment, and 1-segment blocks without guard bands. With this feature, receivers can demodulate a 1-segment block or demodulate only the center blocks of 3- or 13-segment blocks so that the hardware and software resources for the ISDB-T family receivers can be used to make receivers for the ISDB-T multimedia broadcasting for mobile reception.

9.5.4 Performance of ISDB-T

Recommendations ITU-R BT.1306 [9.33] and ITU-R BT.1368 [9.42] describe system characteristics such as modulation, capacity, transmission parameters, and minimum field strength.

Recommendation ITU-R BT.1833 [9.35] describes the One-Seg service.

Local and wide coverage area. ISDB-T multimedia broadcasting system can cover a local coverage area by using one transmitter or cover a wide area with a single frequency network (SFN) using several transmitters. This avoids the need for complex frequency handoff requirements.

Low power consumption. ISDB-T multimedia broadcasting's handheld terminal can receive and decode ISDB-T_{SB} signals and the centre segment of ISDB-T signals. These bandwidths are narrow, so the handheld terminal can use a low clock frequency and have low power consumption.

Flexible bandwidth. ISDB-T multimedia broadcasting system can adapt its bandwidth by combining several basic segment blocks in accordance with the bandwidth of the allocated RF channel.

Multiple programmes in one segment. Multiple programmes can be transmitted in one segment. For example, when the transmission parameters are QPSK modulation, a 2/3 error correction (FEC) coding rate, and a 1/8 guard interval ratio, ten audio programmes (32 kbit/s/programme) or two 5.1 surround audio programmes (160kbit/s/programme) can be transmitted in one segment. Furthermore, several broadcasting providers can transmit programmes in one segment at the same time.

9.5.5 Summary of system parameters

Table 9.39 summarises characteristics of ISDB system (see Report ITU-R BT.2295-1 [9.43]).

TABLE 9.39
Key characteristics of ISDB system

Characteristics	ISDB-T family
Reception modes: – Fixed – Portable – Portable handheld – Mobile	+ + + +
Net data rates	n × a) 0.281 to 1.787 Mbit/s b) 0.328 to 2.085 Mbit/s c) 0.374 to 2.383 Mbit/s
Spectrum efficiency (bit/s/Hz)	0.66-4.17
Single frequency networks	Supported
Broadcasting types: – sound – multimedia – TV	+ + +
Transmission data/service types	Video, audio, data
Frequency bands	VHF, UHF
Channel bandwidth	1/14 × n of a) 6 MHz b) 7 MHz c) 8 MHz n ≥ 1 ¹
Used bandwidth	Subcarrier spacing + 1/14 × n × a) 6 MHz b) 7 MHz c) 8 MHz n ≥ 1 ¹
Number of segments	n ≥ 1 ¹
Number of subcarriers per segment	108 (Mode 1) 216 (Mode 2) 432 (Mode 3)
Subcarrier spacing	a) 3.968 kHz (Mode 1) ² , 1.984 kHz (Mode 2), 0.992 kHz (Mode 3) b) 4.629 kHz (Mode 1), 2.314 kHz (Mode 2), 1.157 kHz (Mode 3) c) 5.291 kHz (Mode 1), 2.645 kHz (Mode 2), 1.322 kHz (Mode 3)
Active symbol duration	a) 252 μs (Mode 1) ² , 504 μs (Mode 2), 1 008 μs (Mode 3) b) 216 μs (Mode 1), 432 μs (Mode 2), 864 μs (Mode 3) c) 189 μs (Mode 1), 378 μs (Mode 2), 756 μs (Mode 3)
Guard interval duration/ ratio	1/32, 1/16, 1/8, 1/4
Frame duration	204 OFDM symbols
Time/ frequency synchronization	Pilot carriers
Modulation methods	DQPSK, QPSK, 16-QAM, 64-QAM
Inner FEC	Convolution code, Mother rate 1/2 with 64 states. Puncturing to rate 2/3, 3/4, 5/6, 7/8

TABLE 9.40 (end)

Item	Mobile Reception			Handheld Reception (Outdoors)			Fixed Reception		
Receiver noise bandwidth (one-segment) (kHz)	429	429	429	429	429	429	429	429	429
Receiver thermal noise power (dBm)	-112.7	-112.7	-112.7	-112.7	-112.7	-112.7	-112.7	-112.7	-112.7
External noise power (dBm)	-98.1	-98.1	-98.1	-115.1	-115.1	-115.1	-99.1	-99.1	-99.1
Total receiver noise power (dBm)	-97.9	-97.9	-97.9	-110.7	-110.7	-110.7	-98.9	-98.9	-98.9
Receiver input terminal voltage (dB μ V)	29.2	30.9	34.5	16.4	18.1	21.7	19.8	21.5	26.4
Reception antenna gain (dBi)	-3	-3	-3	-20	-20	-20	-3	-3	-3
Effective antenna length (dB)	-0.4	-0.4	-0.4	-0.4	-0.4	-0.4	-0.4	-0.4	-0.4
Feeder loss, equipment insertion loss (dB)	1	1	1	1	1	1	2	2	2
Minimum field strength (dB μ V/m)	39.5	41.2	44.8	43.7	45.4	49.0	31.1	32.8	37.7
Correction factor for change in time availability (dB)	0	0	0	0	0	0	6	6	6
Coverage correction factor (correction of median variation) (dB)	4.8	4.8	4.8	4.8	4.8	4.8	0	0	0
Required field strength (h ₂ =1.5m) (dB μ V/m)	44.3	46.0	49.6	48.5	50.2	53.8			
Reception height correction factor (from 1.5 m to 4m) (dB)	2.3	2.3	2.3	2.3	2.3	2.3			
Required field strength (h ₂ =4 m) (dB μ V/m)	46.6	48.3	51.9	50.8	52.5	56.1	37.1	38.8	43.7
Conversion factor for change from one-segment signal to three-segment signal (dB)	4.8	4.8	4.8	4.8	4.8	4.8	4.8	4.8	4.8
Required field strength for three-segment signal (h ₂ =4 m) (dB μ V/m)	51.4	53.1	56.7	55.6	57.3	60.9	41.9	43.6	48.5

9.5.7 Example of possible use of the ISDB system

The following are typical examples of ISDB-T applications (see also Figure 9.50):

- **HDTV programs:** Viewers can enjoy high-quality images with a 16×9 aspect ratio and CD quality sound. ISDB-T also supports 5.1 multi-channel surround audio.
- **Multiple SDTV programs:** A maximum of eight Standard Definition TV programs can be transmitted in a single channel.
- **EPG (Electronic program guide):** The electronic program guide enables viewers to show the TV programs, and make a registration for TV program recording.
- **Data broadcasting:** Data broadcasting provides information on demand through viewer's interactive operation with a remote control. It provides access to news, traffic conditions, weather forecasts, recipes, sightseeing guides, and educational games.
- **Internet access:** All ISDB-T television receivers can be linked to the Internet to access additional information. The latest receivers also support IPTV.
- **HDTV mobile reception:** HDTV programs broadcast through ISDB-T can be viewed on mobile receivers. Several types of car receivers are now on the market.

- **One-Seg service: TV service for handheld/portable receivers:** One-Seg TV service for cellular phones or portable TV receivers is available. Phones equipped with One-Seg can also receive data through their communications functionality. For this kind of reception, new network-linked data broadcast services that combine data broadcasting and information obtained through a communications network are being studied. One-Seg receivers will also be equipped with an automatic power-on function for receiving disaster alerts from the early warning broadcasting system (EWBS).

FIGURE 9.50

Typical ISDB-T Applications

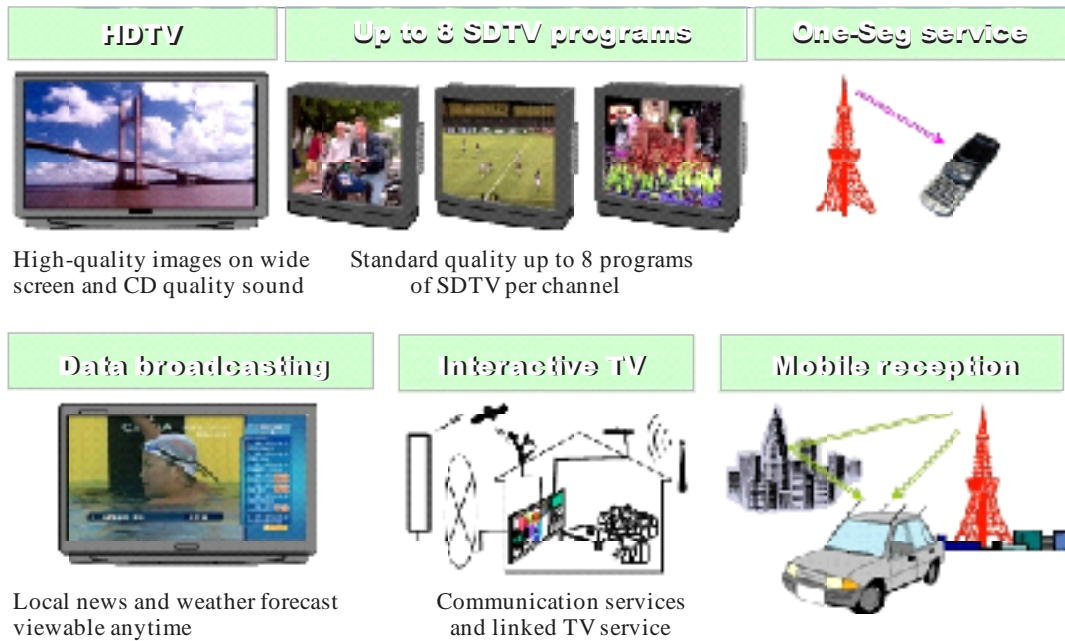

DTTB-09-50

Figure 9.51 shows the service image of ISDB-T multimedia broadcasting. Various video, audio, and data can be transmitted to mobile/handheld terminals. People can listen to music on the air or after download anywhere and anytime. Moreover, people can access the Internet through the system's wireless communication capability.

FIGURE 9.51
Service image of ISDB-T multimedia broadcasting

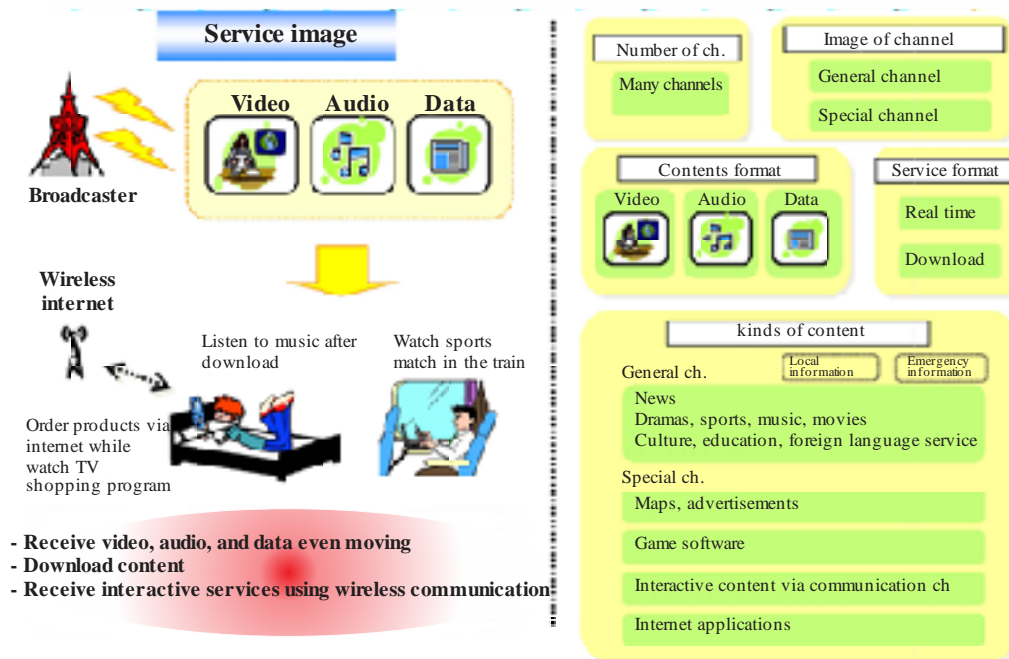

DTTB-09-51

The unique advantages offered by ISDB-T segments in a multimedia broadcasting system, make possible the following services for handheld terminals.

9.5.8 Examples of 1- or 3-segment services

Service examples. Figure 9.52 shows examples of 1-segment services. Several audio services with data, filecasting and PSI/SI are multiplexed in segment 1. PSI/SI includes two kinds of Electronic Program Guides (EPG), the EPG for audio services and the EPG for filecasting services. The audio services are same quality as AM radio programmes (32 kbit/s). Up-to-date news, weather forecasts, etc., are transmitted by the filecasting service. On the other hand, segment 2 can be used to transmit a video service whose quality is the same as One-Seg service.

FIGURE 9.52

Example of 1-segment service

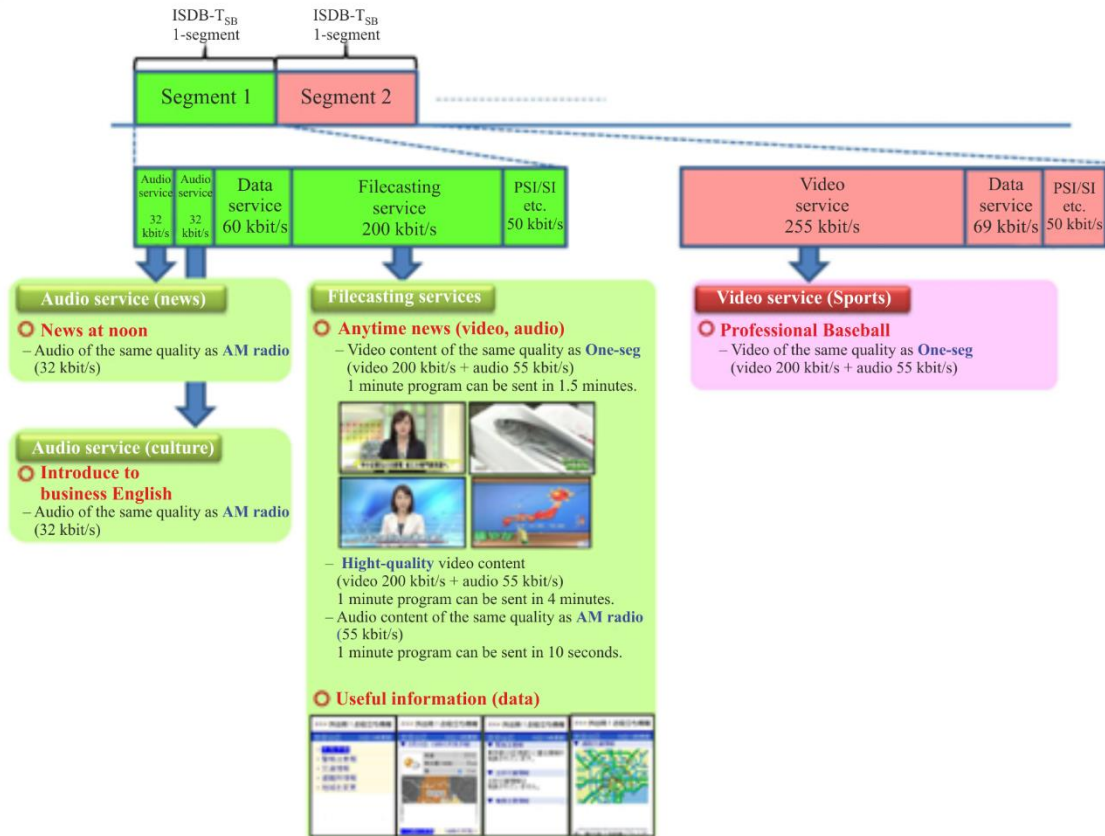

DTTB-09-52

1-segment receiver and 3-segment receiver. Figure 9.53 shows an example of the displayed visual content difference between a 1-segment receiver and a 3-segment receiver. In this example, the program of the ISDB-T_{SB} (3-segment) is composed of sound data, streaming image, PSI/SI, and other data. Sound data, still pictures, and PSI/SI are transmitted in segment 2. Data for content in Broadcast Mark-up Language (BML) carried by carousel, streaming images, and associated data are transmitted in segment 1 and segment 3. A 1-segment receiver can receive sound and still picture/data (shown in the upper part of Figure 9.53), whereas a 3-segment receiver can receive streaming images, sound, and BML content (the lower part of Figure 9.53).

FIGURE 9.53
Relation between three-segment receiver and one-segment receiver

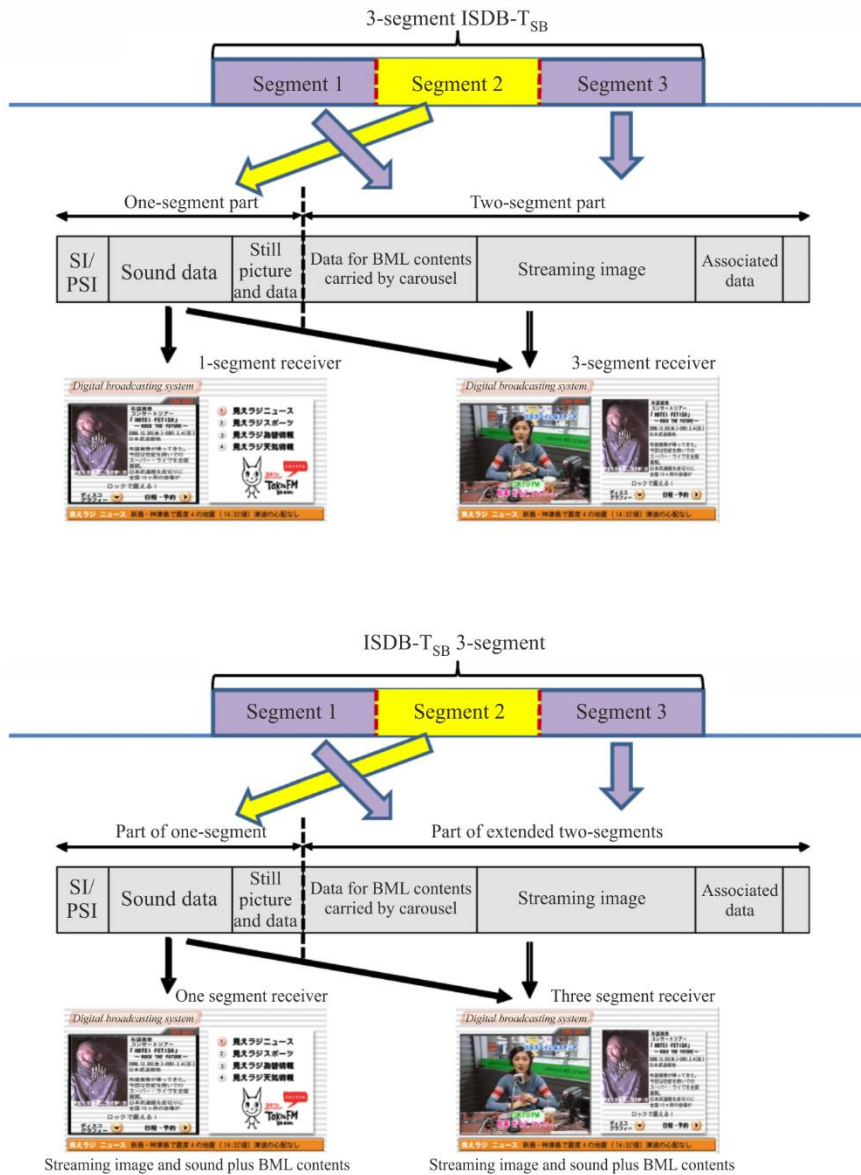

DTTB-09-53

Interactive broadcasting service for handheld receiver connected to communication network. Interactive applications are also important for handheld receivers. Figure 9.54 shows one example using the interactive capability provided by telecommunication networks. In this case, event menu, information about movies, and a time-table of movie presentations are displayed by using BML content sent by carousel transmission. In addition, ticket reservation is done over a communication network.

FIGURE 9.54

Example of interactive broadcasting application using a communication network

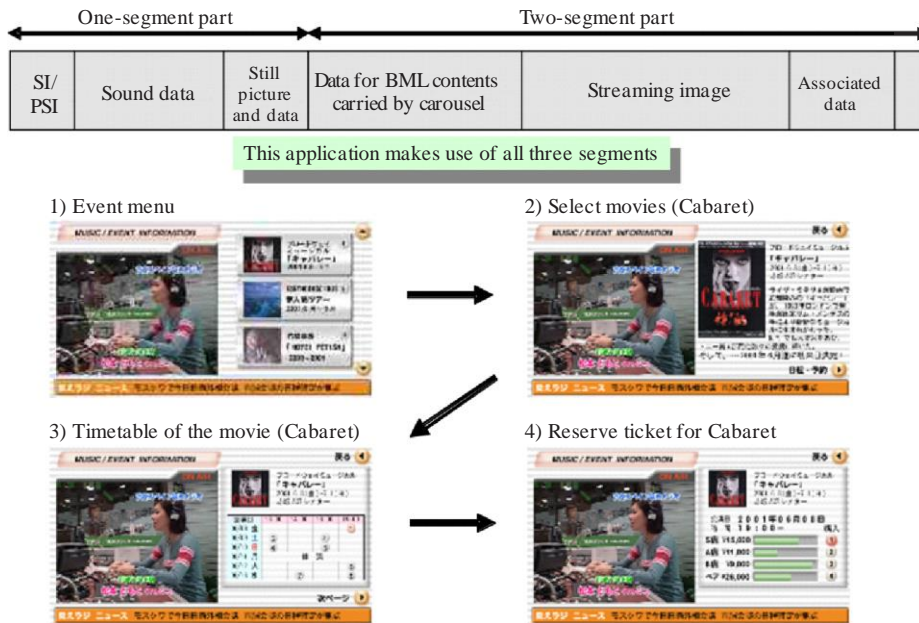

DTTB-09-54

Several types of portable and mobile receivers. Figure 9.55 shows images of typical receivers together with brief explanations about them.

FIGURE 9.55
Some receiver types



DTTB-09-55

- a) Simple pocket radio: sound reception only.
- b) Pocket radio / car radio with simplified display capability of a few lines of characters.
- c) Cellular phone.
- d) Personal digital assistant (PDA).

Three other types of receiver are considered in this Handbook.

- a) 5.1-channel surround stereo receiver for car audio systems.
- b) Fixed digital sound receiver for high-fidelity stereo sound systems.
- c) PCMCIA card receiver for open-box devices such as PDAs and notebook PCs.

9.5.9 Examples of 1- or 13-segment services

A combination of filecasting and real-time broadcasting would be a typical service. Figures 9.56 and 9.57 show examples of filecasting and real-time broadcasting.

FIGURE 9.56
Example of filecasting



DTTB-09-56

FIGURE 9.57
Example of multi-channel real-time broadcasting



DTTB-09-57

If a palmtop receiver able to receive ISDB-T multimedia broadcasting is available, its user-friendly navigation can help a user to access the real-time broadcasting service and stored data provided by filecasting. Figure 9.58 shows an example of a filecasting service. The pictures on the left and right of this figure respectively indicate the downloading percentage and navigation instructions for the user to access the data.

FIGURE 9.58
Example of filecasting service on a palmtop receiver



DTTB-09-58

Figure 9.59 shows an example of a program line-up. ISDB-T multimedia broadcasting can provide rich content, ranging from news, sports, and movies, to music, novels, stock prices, and games.

FIGURE 9.59
Example of program line-up

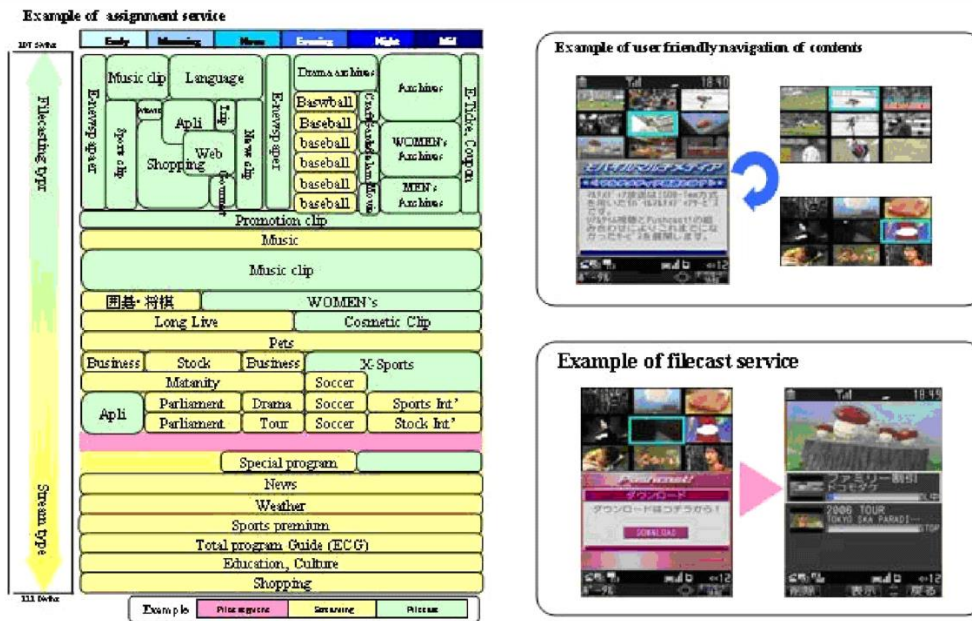

DTTB-09-59

9.6 DTMB and DTMB-A

DTMB (Digital Television Terrestrial Multimedia Broadcasting) was developed and ratified by Standardization Administration of the People's Republic of China, as GB20600-2006 “Framing structure, channel coding and modulation for digital television terrestrial broadcasting system” [9.45].

The DTMB system is designed to provide reliable and high-performance video, sound and data broadcasting service, for all fixed, portable, mobile and handheld receivers. Due to the adoption of technologies like Time-Domain Synchronous OFDM (TDS-OFDM) and concatenated error-correction codes combining Low Density

Parity Check (LPDC) code and BCH code, the DTMB system has the advantages of high spectrum efficiency, large coverage, high mobility, and can strongly combat multi-path interface.

DTMB system has a wide variety of transmission parameters such as the combination of the constellation mode, guard interval duration, inner channel code, etc. As the data interface supported by DTMB is flexible, all data stream with a TS structure including MPEG-2, MPEG-4/H.264, AVS and DRA, etc. can be transmitted. Other data structures can also be supported after conversion. The DTMB standard can support fixed or mobile as well as indoor/outdoor reception for high definition TV (HDTV), standard definition TV (SDTV), or multimedia data broadcasting services. The bandwidth of DTMB system used in China is 8 MHz. DTMB can also support bandwidth of 6 MHz and 7 MHz. So DTMB can be used in different countries with different bandwidth modes. The data and figures in this section are shown for the system with 8 MHz channel bandwidth.

A more recent, more efficient variant of DTMB is DTMB-Advanced (DTMB-A) which is given as System E in [9.33]. The corresponding national standard is Chinese Standard GD/J 068-2015 “Frame Structure, Channel Coding and Modulation for Digital Television/Terrestrial Multimedia Broadcasting-Advanced (DTMB-A)” [9.46]. This variant provides higher efficiency than DTMB in terms of noise and interference immunity due to advanced error correction, interleaving and constellation mapping methods. Such enhancements extend the possibilities of the system up to HDTV and data broadcasting with possibility of working in single and multiple frequency networks.

Additional information on DTTB introduction in China is provided in [9.152].

9.6.1 Architectural model

An example of the protocol stack used in the DTMB system is provided in Figure 9.60. The basic protocol for audio-visual information transmission over physical media is the MPEG-2 transport stream.

FIGURE 9.60
Example of DTMB protocol stack

Application (reproduction, recording etc)					
MPEG-4 AVC	MPEG-2 video	MPEG audio	AC-3, DTS	Subtitles, teletext	EPG, ESG
				PSI	SI
PES MPEG-2				MPEG-2 section	
Transport stream					
Physical layer of DTMB (LPDC, M-QAM etc.)					

DTTB-09-60

The DTMB standard supports a range of bit-rates (i.e. system payload data rates) from 4.813 Mbit/s to 32.486 Mbit/s. It is important to know the bit-rates needed for different services for frequency/network planning. Because the video quality depends on the compression algorithm, the compression ratio, the number of the cascaded stages of the compression, and the choice of data rate should be based on the comprehensive consideration of the entire capturing, recording, editing, and modulation chain.

Typical bit-rates for different picture quality standards and video and audio coding standards can be found in Chapter 3.

DTMB-A supports higher bit-rates per broadcasting channel (up to 49.31 Mbit/s in an 8 MHz channel), with one or multiple pipelines per channel for Variable Coding and Modulation (VCM) mode implementation. Such differentiated protection for services provides better channel utilization efficiency for different types of services (from fixed stationary reception to mobile television). Also it improves system performance in terms of number of TV or multimedia programmes per channel or audio-visual quality of transmitted content (depending on required system trade-off).

9.6.2 Key technologies of DTMB/DTMB-A

Compared with other digital terrestrial television-broadcasting standards, the following key technologies are adopted in DTMB to improve the system performance:

PN Frame Header: In order to achieve system synchronization, channel estimation and equalization, specially designed Pseudo-random Noise code (PN) sequences are inserted as the guard intervals in DTMB system. By using the PN sequences, a receiver can achieve fast and robust synchronization as well as highly efficient channel estimation. The frequency domain equalization is also very simple. The PN Frame Header can also be used as the training sequence in a time domain equalizer. Because of the absence of pilots in the data frame body, the spectrum efficiency is also increased in DTMB system.

The detailed benefits and characteristics of using a PN sequence are as follows:

- A PN sequence inserted as the guard interval can be used to achieve system synchronization and channel estimation/equalization. So pilots are not needed and spectrum efficiency is increased.
- The PN sequence is transmitted with spread spectrum technology: perfect auto-correlation and spread spectrum gain can make the synchronization more robust. On the other side, the correlation is performed in the time domain, and therefore, the synchronization will be very quick.
- Benefit from the auto-correlation and randomness of the known PN sequence, the channel estimation of the DTMB system only relates to the current frame. So it will be easy to satisfy the requirement of high-speed mobile reception.
- The PN sequence is known at the receiver, so the interference from the PN sequence to the Frame Body can theoretically be removed by a correlation operation after the synchronization and channel estimation. After this processing, the same Frame Body signal with zero-padded OFDM signal can be obtained. It has been proved theoretically that the system performance of zero-padded guard interval is same as that of the cyclic extension guard interval under the same channel condition.

The DTMB-A super frame contains a specific synchronization channel used for fast signal acquisition, coarse timing synchronization and carrier frequency offset estimation. Pilot information is transmitted by DBPSK method in one OFDM symbol with two cyclic prefixes

Advanced channel coding: The outer and inner codes used in DTMB standard are BCH codes and LDPC codes respectively. The code-word length of the LDPC code is 7 488 bits. There are three FEC code rates (BCH+LDPC) in the system, i.e. 0.4 (7488, 3008), 0.6 (7488, 4512), and 0.8 (7488, 6016). The code rate 0.4 has the highest redundancy, but the highest transmission reliability. This mode should be applied to strongly disturbed channels. On the other hand, a code rate of 0.8 has a low redundancy but low error protection capability. The code rate 0.6 is a compromise option.

The outer BCH code helps the rate adaption and lowers the error floor of the system. Through experimental testing, the error floor of the DTMB system has been found to be under 1×10^{-12} .

DTMB-A error protection is also LDPC/BCH based but with a different encoded frame length (a short frame encoded frame length with 15 360 bits and a long frame encoded frame length with 61 440 bits). Possible variants of code rate are 1/2 (30 720, 30 512), 2/3 (40 960, 40 752) and 5/6 (51 200, 50 992) with error correction of up to 13 erroneous bits possible.

System Information protection: System Information is an important part of the Signal Frame, which is transmitted in the Frame Body symbols. Each Signal Frame includes 36 System Information symbols which are used to provide necessary demodulation and decoding information including constellation mapping modes, LDPC rates, interleaving modes, and subcarriers options (single- or multi-carrier). The receiver can recognize the system mode by using System Information automatically.

In DTMB systems, System Information is transmitted using Walsh code spread spectrum technology to ensure reliable recovery of System Information under severe channel conditions.

The DTMB-A system uses LDPC code rate 2/3 for protection of special system frame description channel and QPSK mapping for better robustness.

9.6.3 Physical layer of DTMB

In DTMB, the following baseband processing will be applied to the input data stream sequentially:

- Scrambling
- FEC
- Constellation mapping
- Interleaving
- Multiplex of Basic Data Block and System Information
- Combine the Frame Body and Frame Header to build the Signal Frame
- Utilizing baseband post-processing to generate baseband signal.

After these processes, the baseband signal will be up-converted to an RF signal in the UHF or VHF band. The block diagram of the DTMB transmission system is shown in Figure 9.61.

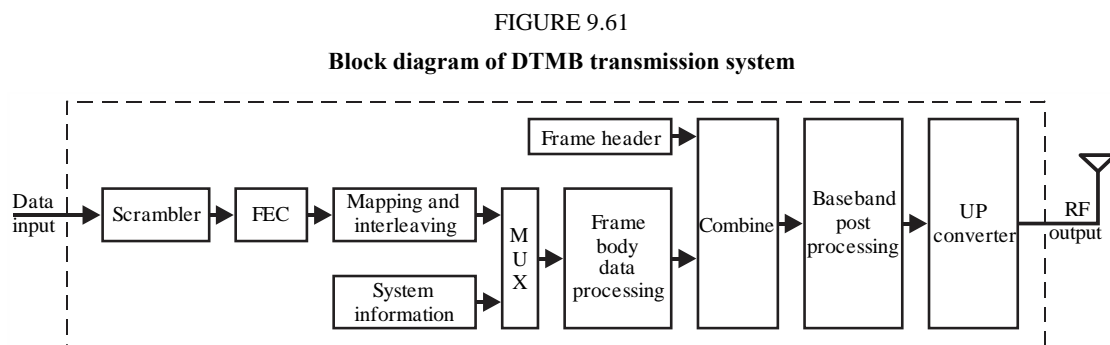

DTTB-09-61

Since the system is designed for digital terrestrial television services to operate within the existing VHF and UHF spectrum allocation for analogue transmissions, it is required that the system provides sufficient protection against high levels of Co-Channel Interference (CCI) and Adjacent Channel Interference (ACI) emanating from existing analogue TV services.

9.6.4 Performance of DTMB

In summary, the following parameters can be chosen in the DTMB system:

- Number of radiated carriers:
 - DTMB: 1 carrier or 3 780 carriers;
 - DTMB-A: 4 096, 8 192 or 32 768 carriers.
- DTMB-A Peak-to-average power ratio (PAPR) reduction: special active constellation extension (ACE) for APSK constellation as options.
- Inner channel code FEC code rates:
 - DTMB: 0.4: 3009/7488, 0.6: 4512/7488, 0.8: 6016/7488;
 - DTMB-A: 1/2, 2/3 and 5/6.
- Constellation modes:
 - DTMB: 64QAM: 6 bits/Hz, 32QAM: 5 bits/Hz, 16QAM: 4 bits/Hz, 4QAM: 2 bits/Hz and 4QAM-NR: 1 bit/Hz;
 - DTMB-A (specific for each Service Channel): QPSK: 2 bits/Hz, 16ASPK: 4 bits/ Hz, 64APSK: 6 bits/Hz, 256APSK: 8 bits/Hz.
- DTMB-A modulated symbol roll-off factor: 0.05 and 0.025.

- Guard interval duration:
 - DTMB: 1/9: 55.6 μ s, 1/6: 78.7 μ s, 1/4: 125 μ s;
 - DTMB-A: 1/128, 1/64, 1/32, 1/16, 1/8 and 1/4 (depending on OFDM mode and roll-off factor, more details in [9.33]).
- Overall symbol (signal frame) duration:
 - DTMB: 555.6 μ s, 578.7 μ s, 625 μ s;
 - DTMB-A: 610-4467 μ s (more details in [9.33]).
- DTMB System frame head: 420, 595, 945 μ s.
- DTMB Time domain interleaving depth: 240, 720.
- DTMB-A specific interleaving: Bit Interleaving and Bit Permutation, Modulation Symbol Interleaving, Time interleaving for specific service channel.
- DTMB-A flexibility: DTMB-A uses Extension Frame concept. The extension frame can be used as Null signals or for uplink services.
- DTMB-A transmit diversity: single and two antenna modes are possible for further improvements of receiver performance. DTMB-A uses an optional 2 \times 1 MISO configuration with Alamouti coding in the space-frequency domain.

These parameters may be combined as required to give the required trade-off between noise immunity and net bit-rate in the TDMB network.

There are five different constellation modes used in DTMB standard for different transmission requirement, i.e. 64-QAM, 32-QAM, 16-QAM, 4-QAM and 4-QAM-NR, with 6 bits, 5 bits, 4 bits, 2 bits and 1 bit per constellation symbol, respectively. For 4-QAM-NR mapping, which is equivalent to 4-QAM mode, NR coding is adopted before 4-QAM mapping. Compared with 4-QAM constellation mode for the given Frame Header mode and FEC code rate, the payload data rate for 4-QAM-NR is half, 16-QAM is doubled and for 64-QAM tripled the payload to that of 4-QAM constellation respectively. For a given FEC code rate and same channel condition, the anti-interference capability of 4-QAM is the best while that of 64-QAM is the worst. Payload rate for DTMB System for all modes is provided in Figure 9.62.

FIGURE 9.62
Payload data rates for DTMB System

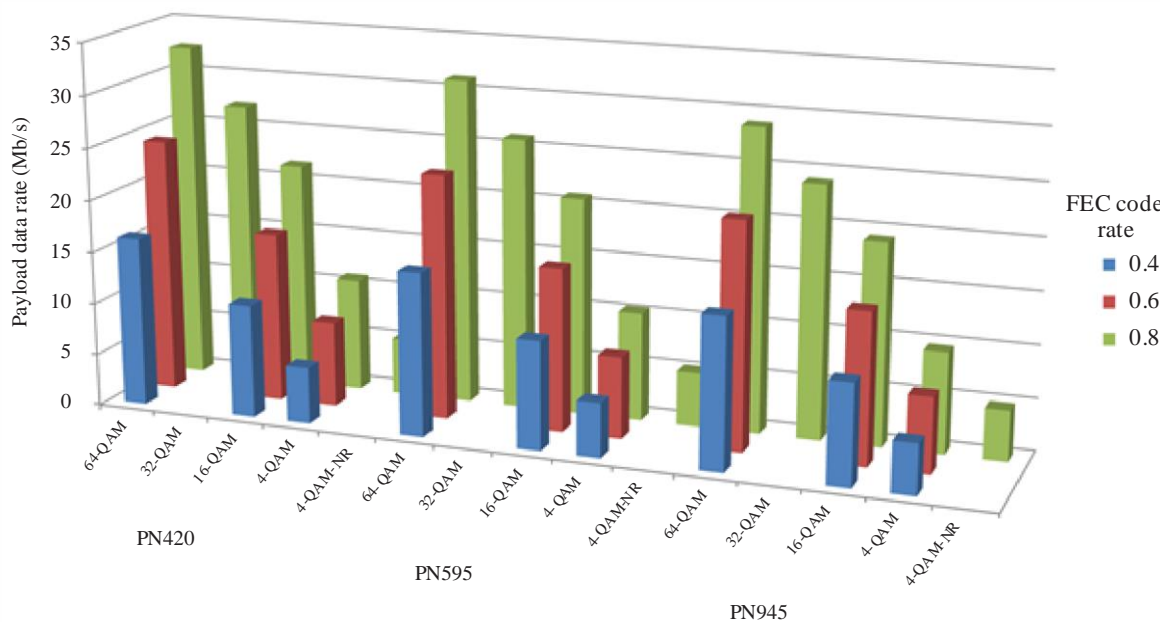

Constellations for DTMB-A are based on QPSK and M-PSK mappings ($M = 16, 64, 256$) with the possibility of a different value of M selected for each separate sub-channel (pipeline). Such operation is called Variable Coding and Modulation (VCM) and used for differentiated transmission of different services. Standard mode (without differentiated transmission) for modulation is possible in Constant Coding and Modulation (CCM).

The FEC code rate 0.4 has the largest redundancy and the best transmission reliability. This mode is suitable for strongly disturbed channels. On the other hand, a FEC code rate of 0.8 has the smallest redundancy and the lowest error protection capability. The same concept is applicable to LDPC rates in DTMB-A. In total DTMB-A provides better error performance than DTMB but with increased complexity of system algorithms and hardware requirements.

In DTMB systems, the Frame Header uses PN sequences, which can be used for fast synchronization and high-efficiency channel estimation/equalization. There are three options for the Frame Header length to deal with multi-path channels. A longer system Frame Head can help combat longer echoes, but will decrease the payload data rate of the system. The longer system Frame Header is suitable for large area SFN operation.

The super-frame of the DTMB-A system has a more complex structure than in DTMB with a specific header (called synchronization channel). The aim of such complexity is to increase receiver synchronization accuracy and to provide additional means for DTMB-A signal identification and discovery in an RF channel. In the synchronization channel, two specific PN sequences after DBPSK modulation are converted in the time domain by. This approach provides increased reliability in receiver.

The time domain interleaving is to improve the anti-impulse interference capability. Time domain symbol interleaving is performed across multiple data symbol blocks. Convolutional interleaving based on constellation symbols is used for time domain interleaving. There are two modes for the time domain interleaving with different interleaving depth parameter M (the buffer size of basic delay module) for the same the number of interleaving branches B of 52. The mode with $M=720$ is for long interleaving, $M=240$ is for short interleaving. The long interleaving mode is suitable for large burst transmission errors. Severe impulse interference or multi-path fading will cause large burst transmission errors.

The interleaving stages in DTMB-A are more complex due to long data blocks and the necessity of reliable data transmission in frequency/time varying channel conditions. There are three stages of interleaving – bit interleaving and permutation after FEC encoding, intra- and inter-symbol interleaving of modulated QPSK or M-APSK symbols and time interleaving for pipeline generation in single and multi-service modes.

The DTMB and DTMB-A systems have satisfactory reception performance both in additive white Gaussian noise (AWGN) and multi-path fading channels, which could be found in complicated multi-path situations and in SFNs.

Figure 9.63 and Table 9.41 illustrates the C/N thresholds for DTMB in AWGN, Ricean and Rayleigh channels. Table 9.42 shows C/N thresholds for DTMB-A in the same three channels. The Ricean channel used to derive these figures is given in Table 9.43 and the Rayleigh channel in Table 9.44.

FIGURE 9.63
C/N threshold for the DTMB system

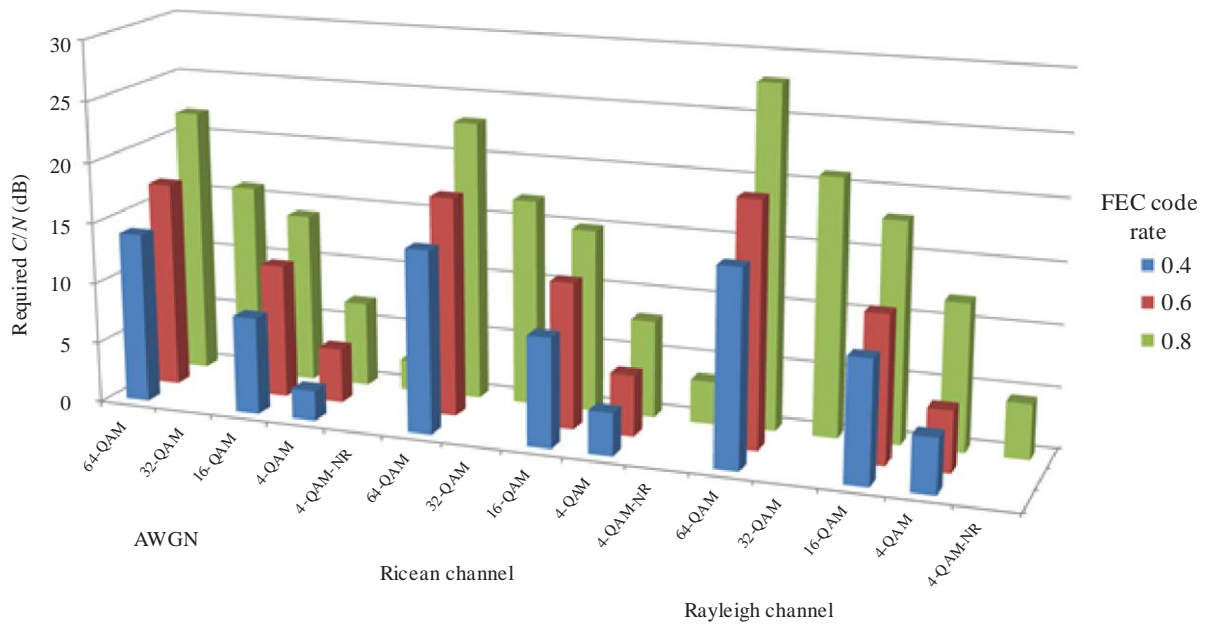

DTTB-09-63

TABLE 9.41
C/N threshold for DTMB system

Constellation	FEC Code rate	C/N threshold (dB)		
		AWGN	Ricean channel	Rayleigh channel
4QAM	0.4	2.5	3.5	4.5
16QAM	0.4	8.0	9.0	10.0
64QAM	0.4	14.0	15.0	16.0
4QAM	0.6	4.5	5.0	7.0
16QAM	0.6	11.0	12.0	14.0
64QAM	0.6	17.0	18.0	20.0
4QAM-NR	0.8	2.5	3.5	4.5
4QAM	0.8	7.0	8.0	12.0
16QAM	0.8	14.0	15.0	18.0
32QAM	0.8	16.0	17.0	21.0
64QAM	0.8	22.0	23.0	28.0

TABLE 9.42
C/N threshold for DTMB-A system

Constellation	FEC Coding rate	Carrier number	LDPC length	Throughput (Mbps)	Carrier-to-noise threshold (dB)		
					AWGN	Ricean channel	Rayleigh channel
QPSK	1/2	4K	61440	6.66	1.2	1.6	3.7
64APSK	2/3	4K	61440	26.69	13.3	14.1	16.8
64APSK	2/3	4K	15360	26.69	13.7	14.4	17.1
256APSK	2/3	32K	61440	39.41	17.9	18.2	21.2
256APSK	5/6	32K	61440	49.31	22.4	22.8	27.4

TABLE 9.43
Ricean channel model for DTMB system

Path	Relative amplitude (dB)	Delay (μ s)	Phase (degree)
Main path	0	0	0
Echo 1	-19.2	0.518650	336.0
Echo 2	-36.2	1.003019	278.2
Echo 3	-26.4	5.422091	195.9
Echo 4	-21.8	2.751772	127.0
Echo 5	-23.1	0.602895	215.3
Echo 6	-35.6	1.016585	311.1
Echo 7	-27.9	0.143556	226.4
Echo 8	-26.1	3.324886	330.9
Echo 9	-19.3	1.935570	8.8
Echo 10	-22.0	0.429948	339.7
Echo 11	-20.5	3.228872	174.9
Echo 12	-23.0	0.848831	36.0
Echo 13	-24.3	0.073883	122.0
Echo 14	-26.7	0.203952	63.0
Echo 15	-27.9	0.194207	198.4
Echo 16	-23.8	0.924450	210.0
Echo 17	-30.1	1.381320	162.4
Echo 18	-24.5	0.640512	191.0
Echo 19	-23.1	1.368671	22.6

TABLE 9.44

Rayleigh channel model for DTMB system

Path	Relative amplitude (dB)	Delay (μ s)	Phase (degree)
1	-7.8	0.518650	336.0
2	-24.8	1.003019	278.2
3	-15.0	5.422091	195.9
4	-10.4	2.751772	127.0
5	-11.7	0.602895	215.3
6	-24.2	1.016585	311.1
7	-16.5	0.143556	226.4
8	-25.8	0.153832	62.7
9	-14.7	3.324886	330.9
10	-7.9	1.935570	8.8
11	-10.6	0.429948	339.7
12	-9.1	3.228872	174.9
13	-11.6	0.848831	36.0
14	-12.9	0.073883	122.0
15	-15.3	0.203952	63.0
16	-16.5	0.194207	198.4
17	-12.4	0.924450	210.0
18	-18.7	1.381320	162.4
19	-13.1	0.640512	191.0
20	-11.7	1.368671	22.6

For mobile reception, the choice of mapping modes and FEC code rates depends on the system performance in the dynamic multi-path channel with Doppler frequency shift. The required C/N and corresponding Doppler frequency shift in a dynamic channel for combinations of constellation mapping modes and FEC code rates for DTMB system are shown in Table 9.45, where $(C/N)_{\min}$ is the minimum C/N for normal reception when the Doppler frequency is 70 Hz, the corresponding Doppler frequency is the maximum Doppler frequency for normal reception when the C/N is 3dB higher than $(C/N)_{\min}$. The dynamic channel model is given in Table 9.46.

TABLE 9.45

Performance of the DTMB system in a dynamic channel

Constellation	FEC Code rate	$f_d=70\text{Hz}$ (C/N) _{min} (dB)	f_d (Hz) for (C/N) _{min} + 3 dB	Speed (km/h) for (C/N) _{min} + 3 dB			
				65 MHz	200 MHz	500 MHz	700 MHz
4-QAM	0.4	6	62	2692	875	350	250
16-QAM	0.4	12	134	2226	724	290	207
4-QAM	0.6	10	148	2459	799	320	228
16-QAM	0.6	17	116	1927	626	251	179
4-QAM-NR	0.8	6	162	2692	875	350	250
4-QAM	0.8	14	123	2044	664	266	190

TABLE 9.46

Dynamic channel model for DTMB system

Taps	Gain (dB)	Delay (μ s)	Doppler type
1	-3	0	Ricean
2	0	0.2	Ricean
3	-2	0.5	Ricean
4	-6	1.6	Ricean
5	-8	2.3	Ricean
6	-10	5.0	Ricean

DTMB-A performance: The required C/N ratio over an AWGN channel for DTMB-A is in the range 0.62-21.08 dB for different combinations of modulation (QPSK, M-APSK) and channel code (1/2, 2/3, 5/6). These values are for a BER= 1×10^{-5} and 7.56 MHz system bandwidth. Additional information on DTMB-A performance is provided in the “Field test report of Evolution System for DTMB” [9.47].

9.6.5 Summary of system parameters

Table 9.47 summarises the characteristics of the DTMB system (also see [9.43]). Table 9.48 summarises the characteristics of DTMB-A.

TABLE 9.47

Key characteristics of DTMB system

Characteristics	DTMB
Reception modes: – Fixed – Portable – Portable handheld – Mobile	+ + + +
Net data rates	Depending on modulation, code and frame header: a) 3.610-24.436 Mbit/s b) 4.211-28.426 Mbit/s c) 4.813-32.486 Mbit/s
Spectrum efficiency (bit/s/Hz)	0.64-4.30
Single frequency networks	Supported
Broadcasting types: – sound – multimedia – TV	+ +
Transmission data/service types	Video, audio, data
Frequency bands	VHF, UHF
Channel bandwidth	a) 6 MHz b) 7 MHz c) 8 MHz
Used bandwidth	a) 5.67 MHz b) 6.62 MHz c) 7.56 MHz
Number of segments	1
Number of subcarriers per segment	1 (single-carrier mode), 3 780 (multi-carrier mode)

TABLE 9.47 (end)

Characteristics	DTMB
Subcarrier spacing	Multi-carrier mode: a) 1.5 kHz b) 1.75 kHz c) 2.0 kHz
Active symbol duration	a) 0.176 μ s (single-carrier mode) 666.67 μ s (multi-carrier mode) b) 0.151 μ s (single-carrier mode) 571.43 μ s (multi-carrier mode) c) 0.132 μ s (single-carrier mode) 500 μ s (multi-carrier mode)
Guard interval duration/ ratio	Frame header 1/9, 1/6, 1/4 of frame body: a) 74.07, 104.94, 166.67 μ s b) 63.49, 89.95, 142.86 μ s c) 55.56, 78.70, 125.00 μ s
Frame duration	a) 740.74, 771.60, 833.33 μ s b) 634.92, 661.38, 714.29 μ s c) 555.56, 578.70, 625.00 μ s
Time/ frequency synchronization	PN sequence as the frame header of signal frame
Modulation methods	4-QAM-NR, 4-QAM, 16-QAM, 32-QAM, 64-QAM
Inner FEC	LDPC code 0.4 (7 488, 3 008), 0.6 (7 488, 4 512), 0.8 (7 488, 6 016)
Inner interleaving	In frequency domain inside one signal frame (multi-carrier mode)
Outer FEC	BCH (762, 752) derived from BCH (1 023, 1 013)
Outer interleaving	Convolutional interleaving in time domain, number of interleaving branches B = 52, interleaving depth M = 240, 720
Data randomization/ energy dispersal	PRBS
Hierarchical transmission	–
Transmission parameter signalling	Carried by 36 system information symbol per signal frame

TABLE 9.48

Key characteristics of DTMB-A system

Characteristics	DTMB-A
Reception modes: – Fixed – Portable – Portable handheld – Mobile	+ + + +
Net data rates	Depending on modulation, code and frame header: a) 3.75-37 Mbit/s b) 4.38-43.1 Mbit/s c) 5.0-49.31 Mbit/s
Spectrum efficiency (bit/s/Hz)	2-8 (without FEC encoding)
Single frequency networks	Supported
Broadcasting types: – sound – multimedia – TV	+ +
Transmission data/service types	Video, audio, data
Frequency bands	VHF, UHF

TABLE 9.48 (end)

Characteristics	DTMB-A
Channel bandwidth	a) 6 MHz b) 7 MHz c) 8 MHz
Used bandwidth	a) 5.67 MHz (roll-off 0.05); 5.83 MHz (roll-off 0.025) b) 6.62 MHz (roll-off 0.05); 6.81 MHz (roll-off 0.025) c) 7.56 MHz (roll-off 0.05); 7.78 MHz (roll-off 0.025)
Number of segments	Configurable
Number of subcarriers per segment	4096 (4k mode), 8192 (8k mode), 32678 (32K mode)
Subcarrier spacing (see Note 1)	a) 1 846 Hz with the roll off factor of 0.05, 1 899 Hz with the roll off factor of 0.025 b) 923 Hz with the roll off factor of 0.05, 949 Hz with the roll off factor of 0.025 c) 231 Hz with the roll off factor of 0.05, 237 Hz with the roll off factor of 0.025
Active symbol duration (see Note 1)	a) 541.80 μ s with the roll off factor of 0.05, 526.63 μ s with the roll off factor of 0.025 b) 1444.80 μ s with the roll off factor of 0.05, 1404.34 μ s with the roll off factor of 0.025 c) 5779.19 μ s with the roll off factor of 0.05, 5617.37 μ s with the roll off factor of 0.025
Guard interval ratio / duration (see Note 1)	a) 1/8, 1/4, 1/2: 67.7, 135, 271 μ s with the roll off factor of 0.05. 65.8 μ s, 132 μ s, 263 μ s with the roll off factor of 0.025 b) 1/16, 1/8, 1/4: 67.7, 135, 271 μ s with the roll off factor of 0.05. 65.8 μ s, 132 μ s, 263 μ s with the roll off factor of 0.025 c) 1/64, 1/32, 1/16: 67.7, 135, 271 μ s with the roll off factor of 0.05. 65.8 μ s, 132 μ s, 263 μ s with the roll off factor of 0.025
Super Frame duration	Super frame starts with super-frame synchronization channel and a control channel for service channel signalling. Each super-frame has configurable number of data signal frames, with maximum duration of 250 μ s
Time/ frequency synchronization	Super-frame synchronization channel and dual PN-MC symbols of each signal frame
Modulation methods	QPSK, 16-APSK, 64-APSK, 256-/APSK specific for each Service Channel
Inner FEC	LDPC code 1/2 (30720, 30512), 2/3 (40960, 40752) and 5/6 (51200, 50992)
Inner interleaving	Bit interleaving, bit permutation for each service channel
Outer FEC	BCH code with block size of 61 440 or 15 360 bits
Outer interleaving	time interleaving separately for each service channel
Data randomization/ energy dispersal	PRBS
Hierarchical transmission	–
Transmission parameter signalling	Service channel signalling is carried by control channel in the super frame. The signal frame size for the control channel is 4096, and the PM-MC symbol length is 1024, modulated with QPSK and coded with punctured 2/3 15360 LDPC for OFDM.

NOTE 1 – Values are indicated for 8 MHz bandwidth. For other bandwidths, see [9.33].

9.6.6 Link budget

The planning criteria of DTMB and DTMB-A are described as System D and E in [9.42].

Table 9.49 and Table 9.50 show typical link budgets for the DTMB and DTMB-A systems.

TABLE 9.49

**Minimum median power flux density and equivalent minimum median field strength
in Band IV and 70% and 95% location probability
(Receiving condition: Outdoor stationary, Urban, Band IV)**

Frequency	f (MHz)	500				
		Minimum C/N required by system	C/N (dB)	2	8	14
Min. Receiver signal input power	P_{smin} (dBW)	-126.2	-120.2	-114.2	-108.2	-102.2
Min. equivalent receiver input voltage (75 Ω)	U_{smin} (dB μ V)	13	19	25	31	37
Cable loss	L_f (dB)	3				
Antenna gain relative to half dipole	G (dBd)	10				
Effective Antenna aperture	A_a (dBm ²)	-3.3				
Min. power flux density at receiving location	Φ_{min} (dBW/m ²)	-119.9	-113.9	-107.9	-101.9	-95.9
Min. equivalent field strength at receiving location	E_{min} (dB μ V/m)	26	32	38	44	50
Allowance for man-made noise	P_{mmn} (dB)	0				
Height loss	L_h (dB)	0				
Location Probability: 70%						
Location correction factor	C_1 (dB)	2.9				
Minimum median power flux density at 10 m a.g.l. 50% of time and 50% of location	Φ_{med} (dBW/m ²)	-117.0	-111.0	-105.0	-99.0	-93.0
Minimum median equivalent field strength at 10 m a.g.l. 50% of time and 50% of location	E_{med} (dB μ V/m)	29	35	41	47	53
Location Probability: 95%						
Location correction factor	C_1 (dB)	9				
Minimum median power flux density at 10 m a.g.l. 50% of time and 50% of location	Φ_{med} (dBW/m ²)	-110.9	-104.9	-98.9	-92.9	-86.9
Minimum median equivalent field strength at 10 m a.g.l. 50% of time and 50% of location	E_{med} (dB μ V/m)	35	41	47	53	59

TABLE 9.50

**Minimum median power flux density and equivalent minimum median field strength
in Band V and 70% and 95% location probability
(Receiving condition: Outdoor stationary, Urban, Band V)**

Frequency	f (MHz)	700				
Minimum C/N required by system	C/N (dB)	2	8	14	20	26
Min. Receiver signal input power	P_{min} (dBW)	-126.2	-120.2	-114.2	-108.2	-102.2
Min. equivalent receiver input voltage (75 Ω)	U_{min} (dB μ V)	13	19	25	31	37
Cable loss	L_f (dB)	5				
Antenna gain relative to half dipole	G (dBd)	12				
Effective Antenna aperture	A_a (dBm ²)	-4.2				
Min. power flux density at receiving location	Φ_{min} (dBW/m ²)	-117.0	-111.0	-105.0	-99.0	-93.0
Min. equivalent field strength at receiving location	E_{min} (dB μ V/m)	29	35	41	47	53
Allowance for man-made noise	P_{mmn} (dB)	0				
Height loss	L_h (dB)	0				
Location Probability:70%						
Location correction factor	C_l (dB)	2.9				
Minimum median power flux density at 10 m a.g.l. 50% of time and 50% of location	Φ_{med} (dBW/m ²)	-114.1	-108.1	-102.1	-96.1	-90.1
Minimum median equivalent field strength at 10 m a.g.l. 50% of time and 50% of location	E_{med} (dB μ V/m)	32	38	44	50	56
Location Probability:95%						
Location correction factor	C_l (dB)	9				
Minimum median power flux density at 10 m a.g.l. 50% of time and 50% of location	Φ_{med} (dBW/m ²)	-108.0	-102.0	-96.0	-90.0	-84.0
Minimum median equivalent field strength at 10 m a.g.l. 50% of time and 50% of location	E_{med} (dB μ V/m)	38	44	50	56	62

The GB/T2666-2011 “Implementation Guidelines for transmission system of digital terrestrial television broadcasting” [9.174] describes in details the methodology for establishing the link budget in different scenarios of implementation of networks.

9.6.7 Examples of using DTMB

Many cities in mainland China including Beijing and Shanghai have already deployed DTMB broadcasting networks. DTMB is also used outside mainland China, for example in Cuba, Laos, Cambodia, Hong Kong and Macau. Different transmission parameters and modes are chosen by different broadcasters to fit their requirements.

DTMB network in Beijing: There are 4 RF channels broadcasting in Beijing. 6 SD programmes are broadcast in the channel with centre frequency 666 MHz with a total bit rate of 21.658 Mbit/s. The channels centred on 674 MHz and 482 MHz each broadcast one HD programme. The bit rate is 20.791 Mbit/s. All these three channels use 16-QAM and 0.8 FEC code rate, while the system frame header differs. All programmes are coded in MPEG2. Another channel centred on 546 MHz focuses on mobile reception; it broadcasts 5 SD programmes coded with Audio Video Coding Standard (AVS) compression.

DTMB network in Hong Kong: The DTMB network in Hong Kong uses 64-QAM constellation, with 0.6 FEC code rate and PN 945 as the system frame header, and data rate of 21.658 Mbit/s in all channels.

A flexible combination of HD and SD programmes is transmitted in single channels to fit different user requirements and save wireless band resource. For instance, the 586 MHz channel transmits 1 HD and 2 SD programs, while the 602 MHz channel transmits 1 HD and 3 SD programs. SFN mode is implemented in both channels mentioned, in which all programmes are coded in H.264.

The MFN mode is also applied in Hong Kong, and several programmes are broadcast with H.264 coding in these channels.

DTMB network in Shanghai: In Shanghai, the channel with centre frequency 802 MHz uses 32-QAM, 0.8 FEC code rate and PN 595 system header. The bit rate is 25.989 Mbit/s. AVS video coding technology is implemented: a maximum of 16 SD programmes are transmitted at the same time.

In the 706 MHz channel, a parameter combination of 16-QAM, 0.6 FEC code rate, PN 945 frame header and 14.438 Mbit/s bit rate is used. This channel is mainly used for commercial applications, such as mobile TV, TVs in buildings and subways, electronic bus-boards and data broadcasting service. Some of the programmes are broadcast with CA. Different video coding schemes are used in this channel, including MPEG-2 and AVS.

9.7 T-DMB

T-DMB (Terrestrial Digital Multimedia Broadcasting) system is the extended system compatible with Digital Sound Broadcasting System A, which enables video services using T-DAB networks for handheld receivers in a mobile environment. It is designated as Multimedia System A in [9.35].

T-DMB can cover a wide area with one single transmitter because it is generally implemented in the VHF band which relatively requires lower usable field strength. Low field strength requires consequently lower transmitter power and reduces the maintenance cost. If there are already T-DAB networks installed for audio services only, T-DMB networks can be introduced without needing to replace the T-DAB transmitters. Only installation of an ensemble multiplexer including video encoder is required to make video and data applications available as well as digital audio. It can be economical to provide T-DMB services over T-DAB transmitters and T-DMB system provides multimedia services in addition to audio services.

9.7.1 Architectural and protocol stack model

The T-DMB protocol stack is presented in Table 9.51.

TABLE 9.51
T-DMB protocol stack

Display and User Interaction				
Composition and Rendering				
Compression Layer (MPEG-4 AVC, MPEG-4 ER-BSAC or MPEG-4 HE AAC)	Object descriptor	Scene Description Information	A/V Object to Data	Upstream Information
Encapsulation (MPEG-4 Sync Layer)				
Delivery Layer		MPEG-2 TS (PES)		
Outer code (RS code and Interleaver)				
Stream mode of T-DAB (ETSI EN 300 401)				

The multimedia service is composed of three layers: the content compression layer, the synchronization layer and the transport layer. Video compression uses MPEG-4 AVC; audio data may be encoded using MPEG-4 ER-BSAC, MPEG-4 HE-AAC or MUSICAM.

MPEG-4 contents are encapsulated over MPEG-2 TS as illustrated in Table 9.51. To synchronize audiovisual content, both temporally and spatially, ISO/IEC 14496-1 SL (Sync Layer) is employed in the synchronization layer. In the transport layer specified in ETSI TS 102 428 [9.118], some appropriate restrictions are employed for the multiplexing of compressed audiovisual data. For system specifications, see Recommendation ITU-R BT.1833 [9.35], Recommendation BT.2016 [9.119], Recommendation BT.2054 [9.23], Recommendation BT.2055 [9.102], and Report ITU-R BT.2049 [9.112].

Information of these audiovisual services is multiplexed into an MPEG-2 TS and outer channel coding of Reed-Solomon code is applied for good performance of video reception (for the error protection mechanism see ETSI TS 102 427 [9.120]). Other useful information on T-DMB system is provided in [9.154-9.165].

9.7.2 Key technologies

Key technologies of T-DMB are the implementation of video services over T-DAB transmitter and additional error correction for reliable reception.

Compatibility with DAB system (EN 300 401) [9.121]

- T-DMB is fully backward compatible with DAB system. Therefore, T-DMB can be deployed by using existing DAB transmission infrastructure without any modification.
- T-DMB video service can co-exist with DAB radio services using MUSICAM, MPEG-4 ER-BSAC, or MPEG-4 HE AAC in the same ensemble.

Strong forward error protection for robust reception under high-speed mobile environment

- T-DMB applies additional forward error correction method to guarantee high-speed mobile reception of video signal.
- By using two well-known error protection mechanisms for digital television system, RS code and convolutional interleaver, T-DMB service can be stably received even in a high speed train running at 300 km/h.

Multimedia system with efficient usage of bits

- T-DMB is based on the efficient multimedia compression technologies such as ISO/IEC 14496-10 AVC and ISO/IEC 14496-3 ER-BSAC or ISO/IEC 14496-3 HE AAC to maximize the number of video services in an ensemble. [9.122-9.123]
- Carefully designed encapsulation and multiplexing mechanisms based on ISO/IEC 14496-1 [9.124] SL packetized stream and ISO/IEC 13818-1 [9.7] MPEG-2 TS add minimum overhead for packetization and multiplexing.

9.7.3 Physical and link layers

T-DMB provides multimedia services including video, audio, auxiliary data and interactive services delivered through T-DAB system specified in Recommendation ITU-R BS.1114 [9.125]. T-DMB is an extension of T-DAB system and uses the same physical and link layers as T-DAB system. T-DMB can offer interactive services in connection with the mobile networks by using IP-based protocol such as MOT, IPDC and so on.

9.7.4 Performance of system

There is a compromise between performance and capacity. Performance of system is dependent on FEC, FFT size and frequency band in use. T-DMB system is reliable when operated in the VHF band than in the UHF band, since the VHF band requires lower field strengths compared with the UHF band.

Quasi Error Free (QEF) reception of video service requires the BER characteristics of 1×10^{-8} after the decoder. It is possible for T-DMB system to obtain stable video reception by applying outer code of Reed-Solomon (188, 204) and convolutional interleaving. The Republic of Korea conducted a field test in order to estimate the performance of T-DMB system for video reception in motion. Before the field test, subjective quality evaluation tests were carried out in a lab to find the threshold value for objective quality not enough for a good quality. The lab test result was interpreted that it is acceptable for good video reception when the bit error rate is lower than 2×10^{-4} BER before the decoder. The field test examined if the measured BER meets the threshold error rate derived from the lab test and concluded that T-DMB showed good performance of video reception even.

9.7.5 Summary of system parameters

Table 9.52 defines characteristics of T-DMB/ AT-DMB systems (also see Report ITU-R BT.2295-1 [9.43]).

TABLE 9.52

Key characteristics of T-DMB/ AT-DMB systems

Characteristics	T-DMB, AT-DMB
Reception modes: – Fixed – Portable – Portable handheld – Mobile	+ + + +
Net data rates	T-DMB: 0.576 to 1.728 Mbit/s AT-DMB: 0.864 to 2.304 Mbit/s at BPSK over DQPSK AT-DMB: 1.152 to 2.88 Mbit/s at QPSK over DQPSK
Spectrum efficiency (bit/s/Hz)	T-DMB: 0.38-1.13 AT-DMB: 0.56-1.88
Single frequency networks	Supported
Broadcasting types: – sound – multimedia – TV	+ + +
Transmission data/service types	Video, audio, data
Frequency bands	VHF, UHF
Channel bandwidth	1.712 MHz
Used bandwidth	1.536 MHz
Number of segments	1
Number of subcarriers per segment	192; 384; 768; 1 536

TABLE 9.52 (end)

Characteristics	T-DMB, AT-DMB
Subcarrier spacing	a) 8 kHz b) 4 kHz c) 2 kHz d) 1 kHz
Active symbol duration	a) 156 μ s b) 312 μ s c) 623 μ s d) 1 246 μ s
Guard interval duration/ ratio	a) 31 μ s b) 62 μ s c) 123 μ s d) 246 μ s
Frame duration	96 ms; 48 ms; 24 ms
Time/ frequency synchronization	Null symbol and centre frequency and phase reference symbol
Modulation methods	T-DMB: DQPSK AT-DMB: DQPSK; BPSK over DQPSK; QPSK over DQPSK
Inner FEC	T-DMB: Convolution code (1/4 to 3/4) AT-DMB: Convolution code + Turbo code (1/4 to 1/2)
Inner interleaving	Time interleaving and frequency interleaving
Outer FEC	RS (204, 188, T=8) code for video service and scalable video service
Outer interleaving	Convolutional interleaving for video service and scalable video service
Data randomization/ energy dispersal	16 bit PRBS
Hierarchical transmission	–
Transmission parameter signalling	Phase reference symbol

9.7.6 Link budget

T-DMB is implemented over T-DAB transmission system with planning parameters specified in Recommendation ITU-R BS.1660. Transmission mode I permits a regional SFN and T-DMB service in the VHF band. T-DMB supports 1.729 Mbit/s of net data rate in an ensemble of 1.536 MHz, therefore three or four video channels are available including auxiliary data applications.

Usable field strengths for T-DMB in Band III are comparable with the values for T-DAB described in Recommendation ITU-R BS.1660. The document shows that it is appropriate to provide good video reception with 59 dB(μ V/m) of field strength based on 1/2 of FEC for 99% of time at 1.5 m of receiver antenna height. In dense populated places gap-fillers may be needed to compensate shadow areas such as underground or indoors in urban places. T-DMB networks having a main high-power transmitter with several low-power gap-fillers provide more efficient method for mobile multimedia rather than dense transmission networks only having numerous low-power transmitters.

9.7.7 Examples of possible use of system

T-DMB provides a variety of auxiliary data services such as Electronic Programme Guide (EPG), Broadcast Website (BWS) and Transport Protocol Expert Group (TPEG) information services as well as A/V services. T-DMB is originated from the concept of broadcaster-based business, since it covers wide area with a low power in the VHF band. However, it can also provide interactive services in connection with the mobile networks. In Korea, reception of A/V is free; however, it is allowed to be paid for auxiliary data services including interactive applications. Payment can be given whenever viewers access per application or when buy receivers with an initial charge imposed on receivers' cost.

Real-time news for handheld devices. T-DMB can deliver various contents such as news, stock market, programme information, traffic, weather, sports, and so on by using the MOT protocol as T-DAB defines. Information is updated every 15 to 30 minutes. BWS also makes users accessible to Internet-like web service without return channel through the MOT protocol. T-DMB receiver should support HTML 4.0 compatible web browsers. MOT Slideshow uses mostly X-PAD audio frame to provide data such as still-cut programme information, album jacket, simple maps, commercials, etc.

Real-time traffic information in a car. TPEG application provides real-time information about traffic congestion, road condition, location of gas stations, and so on in connection with the map navigation by GPS signals and enables to find the faster routes. TPEG data consists of Road Traffic Message (RTM), Point of Interest (POI), Congestion and Travel-Time Information (CTT), and CTT Summary Information (CTT-SUM).

Interactive services. T-DMB can provide interactive services by combining A/V services delivered via broadcast channel and data services delivered via mobile communication channel as shown in Figure 9.64.

FIGURE 9.64
Interactive service model of T-DMB

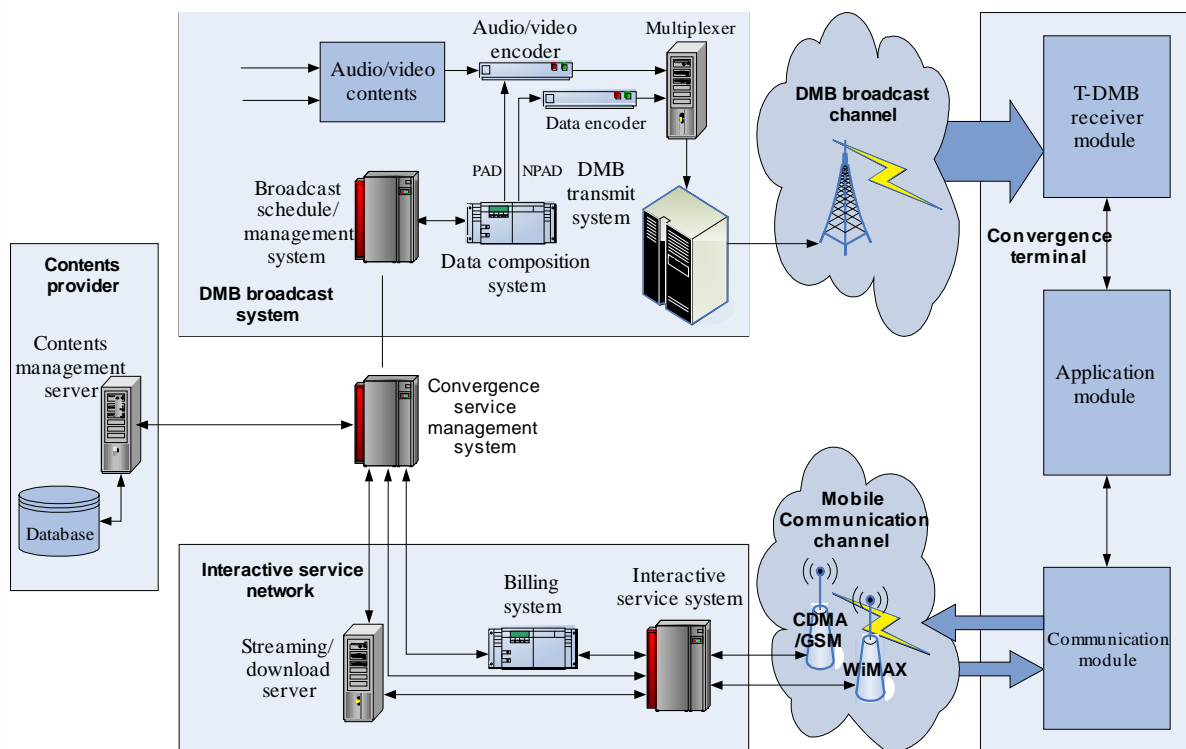

DTTB-09-64

9.7.8 Advanced T-DMB

To increase spectrum efficiency of T-DMB, Advanced T-DMB, so called AT-DMB, was developed. AT-DMB guarantees backward compatibility with T-DMB using hierarchical modulation mechanism. Considering a variety of business models, the AT-DMB defines 2 modes; mode B using BPSK symbol mapping over DQPK and mode Q using QPSK symbol mapping over DQPSK. Mode B hierarchical modulation has better performance in a mobile environment, but it only increases effective data rate up to 1 and 1/2 times that of T-DMB. On the other hand, mode Q hierarchical modulation increases effective data rate up to maximum twice as much as that of T-DMB, but it does not guarantee high performance in a mobile environment. Therefore, mode Q hierarchical modulation is more advantageous in a fixed reception environment and a low speed environment.

9.8 RAVIS

Digital terrestrial multimedia broadcasting system RAVIS (Real-time Audio-Visual Information System) is designed for use in the terrestrial VHF broadcasting bands. The frequency range used by RAVIS enables to deploy local broadcasting. At the same time, the coverage radius of the transmitter is large enough to provide reception in remote places.

The RAVIS system is designed for high quality multi-programme sound, video with several sound accompaniment channels and other data (both related and unrelated to sound and video programmes) broadcasting services. These services should be provided in various conditions, including driving in dense city environment, in woody and mountainous terrain, in water areas; i.e. a reliable reception must be provided in motion, in the absence of direct line of sight of the transmitter antennas and multipath signal propagation.

The RAVIS system is included into Reports ITU-R BT.2049 [9.112], BS.2214 [9.113] and BT.2295-1 [9.43].

9.8.1 Architectural and protocol stack model

The basic service requirements for RAVIS are as follows:

- High spectral efficiency of the system;
- Reliable mobile reception of video, audio and other services at velocities up to 200 km/h;
- Short delay of reception starting or recovery of reception after interruption in complex conditions (for instance, after leaving the tunnel where signal reception was broken);
- Providing high quality video broadcasting with frame sizes up to 720×576 , frame rate up to 25 fps, multiple sound accompaniment channels;
- Providing high quality audio broadcasting, including stereo sound with CD quality and multichannel sound 5.1;
- Providing additional data services related or unrelated to video or audio programme, such as:
 - text messages;
 - still images;
 - slide-show;
 - traffic information, weather information, local news, etc.;
 - EPG.
- Providing conditional access to services;
- Providing reliable emergency alerting service;
- SFN operation, including those along highways and railways.

System receiver should enable to receive new digital programmes and programmes from analogue FM-broadcasting station with automatic detection of the programme type.

At the present time the most perspective for utilization in RAVIS are audio codec HE-AAC (including SBR, PS, MPEG Surround techniques) and video codecs H.264/AVC, H.265/HEVC. Audio encoder HE-AAC provides high quality stereo sound at 32 kbit/s and video encoders H.264/AVC, H.265/HEVC provide high quality video with standard TV definition and 25 fps frame rate at bitrate about 500 kbit/s.

Physical layer and other used elements of lower protocol layers of Open System Interconnection (OSI) are defined in RAVIS transmission system.

Main components of application layer are real-time audio and audiovisual applications and some supplementary services such as Electronic Programme Guide etc. Presentation layer includes source encoding. Multiplexing of audio, video and supplementary data is performed at link layer using MPEG-2 transport stream or RAVIS transport container.

Example of protocol stack for RAVIS system is illustrated in Figure 9.65.

FIGURE 9.65
RAVIS protocol stack

Application layer	Real-time audio and video application	Electronic programme guide
Presentation layer	H.264/MPEG-4 AVC, H.265/MPEG-H HEVC (video) HE-AAC (audio)	XML, HTML, JSON
Link layer	Transport stream MPEG-2 TS, transport container RAVIS TC	
Physical layer	Physical layer RAVIS (BCH, LDPC, M-QAM, OFDM)	

DTTB-09-65

9.8.2 Key technologies

The system provides three logical data transmission channels. Apart from the Main Service Channel, RAVIS provides data channels with enhanced transmission reliability – Low Bitrate Channel (~12 kbit/s) and Reliable Data Channel (~5 kbit/s). These additional channels may be used, for example, for emergency alerting, etc.

The RAVIS system allows various levels of QAM modulation and various rates of channel coding in the main service channel, which are used to achieve an optimal balance between bitrate and reliability (interference protection).

The main service channel is designed for video and audio data transmission. Maximum bitrate in this logical channel is about 900 kbit/s. Low bit-rate channel is designed for transmission of information with increased reliability, for emergency voice alerting, for example. Bit rate is about 12 kbit/s. Reliable data channel is designed for auxiliary data with high reliability. Bit rate is about 5 kbit/s. The low bit-rate channel and reliable data channel provide higher interference protection and consequently larger coverage and higher stability of reception compared to main service channel.

Digital data bitrates in a single radio channel for all combinations of modulation parameters and FEC rates are given in Table 9.53.

TABLE 9.53
Digital data bit rates in RAVIS system

Constellation	FEC rate	Data stream bit rate (kbit/s)		
		100 kHz channel	200 kHz channel	250 kHz channel
QPSK	1/2	80	160	200
	2/3	100	210	270
	3/4	120	240	300
16-QAM	1/2	150	320	400
	2/3	210	420	530
	3/4	230	470	600
64-QAM	1/2	230	470	600
	2/3	310	630	800
	3/4	350	710	900

Main service channel may use QPSK, 16-QAM or 64-QAM modulation, and FEC coding rates of $R = 1/2$, $2/3$ or $3/4$. Low bit-rate channel uses QPSK modulation, and FEC coding rate of $R = 1/2$. Reliable data channel uses BPSK modulation and FEC coding rate $R = 1/2$.

Pilot carriers and carriers with signal transmission parameters (service carriers) are inserted into multiplexed stream of OFDM symbols. These carriers provide synchronization, channel distortion correction and transmission of additional information (including the parameters of modulation and channel coding, availability of logical data channels, etc.) for the reception side.

Peak-to-average power ratio reduction is not mandatory but recommended.

Figure 9.66 shows the functional block diagram of the transmission part of RAVIS, and Figure 9.67 shows the functional block diagram of a RAVIS receiver.

FIGURE 9.66

The RAVIS transmitter functional block diagram

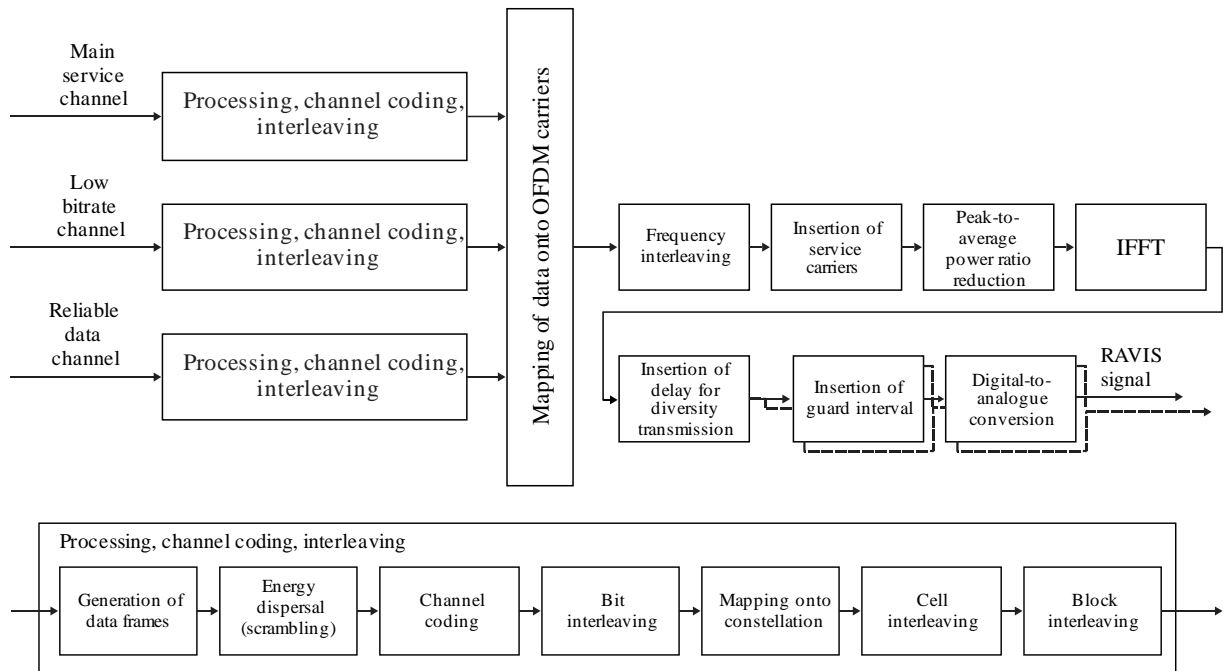
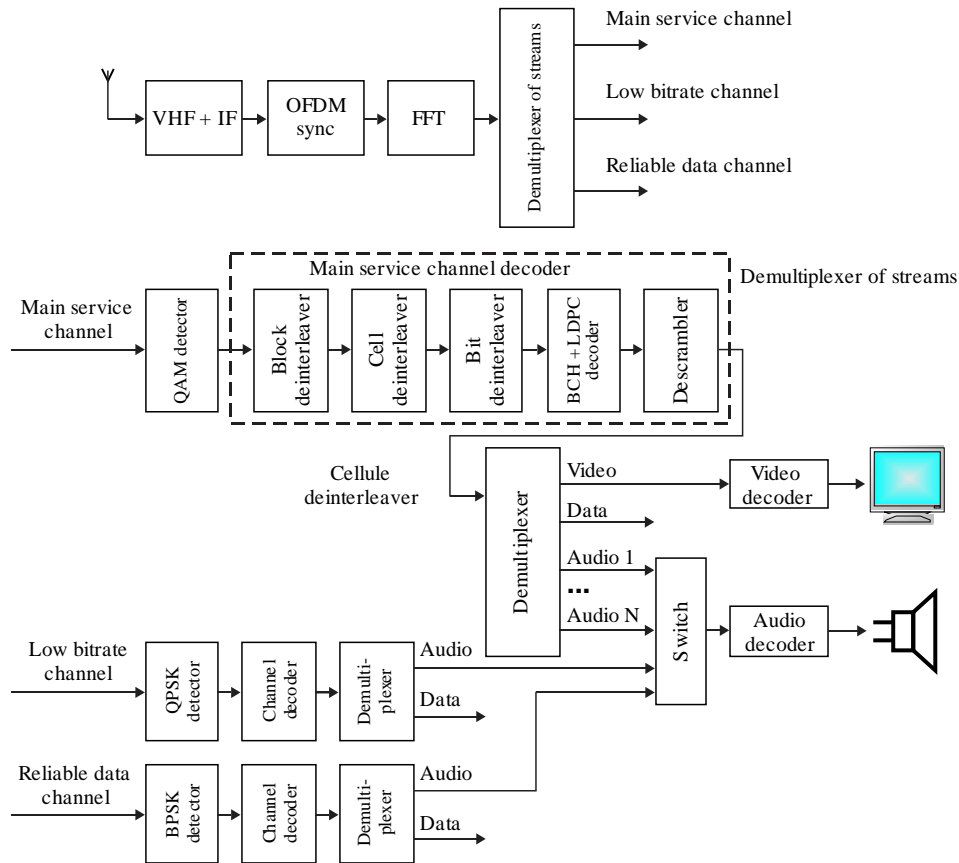

FIGURE 9.67

The RAVIS receiver functional block diagram



DTTB-09-67

The selected frequency band and the selected broadcasting concept have some advantages:

- possibility of utilization of single-frequency network and multi-frequency network;
- broadcasting of multiple high-quality stereo sound programmes or a video stream with a stereo sound accompaniment in a city using only one transmitter;
- ability to localize broadcasting of single programme, i.e. the same frequency is used to broadcast different programmes in various cities.

9.8.3 Physical and link layers

At physical layer the channel coding and OFDM modulation scheme in RAVIS are defined as a functional block for adaptation of data from source encoder to transmission channel characteristics. Data streams from all logical channels are subject of the following transformations:

- data frame generation;
- data frame energy dispersal;
- outer coding (BCH block code);
- inner coding (LDPC block code);
- bit interleaving;
- mapping of bits onto cells of modulation constellation;
- cell interleaving;
- block interleaving;
- mapping of logical channels data onto OFDM cells;

- frequency interleaving and insertion of service carriers;
- peak-to-average power ratio reduction;
- IFFT;
- guard interval insertion, full OFDM signal generation.

At link layer encoded source data may be multiplexed using various formats, including fixed length packets (particularly MPEG-2 TS) and variable length packets (particularly GSE or RAVIS transport container), or non-structured data stream.

9.8.4 Performance of system

Fixed, portable and mobile reception modes of RAVIS signal were simulated using channel models from ETSI ES 201 980 (Annex B.2) [9.126] to evaluate minimum required carrier-to-noise ratio $(C/N)_{min}$ (for BER = 10^{-4} after channel decoder) for various modulation types and coding rates of main service channel. Channel 7 (AWGN) models fixed reception mode, channel 8 (Urban) models portable reception mode, channel 11 (Hilly terrain) models mobile reception mode. Table 9.54 shows these results for 250 kHz channel bandwidth.

TABLE 9.54

$(C/N)_{min}$ values for RAVIS with 250 kHz channel bandwidth, main service channel

Channel model/ reception mode	$(C/N)_{min}$ (dB)								
	QPSK			16-QAM			64-QAM		
	R = 1/2	R = 2/3	R = 3/4	R = 1/2	R = 2/3	R = 3/4	R = 1/2	R = 2/3	R = 3/4
Channel 7 (AWGN)/fixed reception	1.1	3.3	4.2	6.4	9.1	10.2	10.8	14.0	15.4
Channel 8 (urban)/ portable reception	6.4	9.4	11.5	12.5	14.9	17.0	16.2	19.4	22.0
Channel 11 (hilly terrain)/mobile reception	5.5	8.6	9.8	10.4	13.2	15.6	14.7	17.9	20.5

9.8.5 Summary of system parameters

Table 9.55 defines characteristics of RAVIS system (also see Report ITU-R BT.2295-1 [9.43]).

TABLE 9.55

Key characteristics of RAVIS system

Characteristics	RAVIS
Reception modes: – Fixed – Portable – Portable handheld – Mobile	+ + + +
Net data rates	Depending on modulation and code rate for different channel bandwidth: a) 100 kHz-75-341 kbit/s b) 200 kHz-155-703 kbit/s c) 250 kHz-196-888 kbit/s
Spectrum efficiency (bit/s/Hz)	0.77-3.64

TABLE 9.55 (end)

Characteristics	RAVIS
Single frequency networks	Supported
Broadcasting types: – sound – multimedia – TV	+ +
Transmission data/service types	Video, audio, still pictures, presentations, traffic data, etc.
Frequency bands	VHF bands I, II
Channel bandwidth	a) 100 kHz b) 200 kHz c) 250 kHz
Used bandwidth	a) 96.0 kHz b) 185.6 kHz c) 246.2 kHz
Number of segments	1
Number of subcarriers per segment	a) 215 b) 439 c) 553
Subcarrier spacing	4000/9 Hz
Active symbol duration	2.25 ms
Guard interval duration/ ratio	1/8
Frame duration	103.78125 ms (41 OFDM symbols)
Time/ frequency synchronization	Guard interval/ Pilot carriers
Modulation methods	QPSK, 16-QAM, 64-QAM
Inner FEC	LDPC code with approximate code rates 1/2, 2/3, 3/4
Inner interleaving	Bit, cell, time and frequency interleaving
Outer FEC	BCH (n, k, t); n, k depend on channel bandwidth, LDPC code rate; error correction capability t = 10 errors (for main service channel)
Outer interleaving	–
Data randomization/ energy dispersal	16 bit PRBS
Hierarchical transmission	–
Transmission parameter signalling	4 subcarriers per OFDM symbol, 41 bits per OFDM frame

9.8.6 Link budget

Examples of link budget for RAVIS system is provided in Report ITU-R BS.2214 [9.113]. The Report include calculation methodology and the results of calculation of minimum median field strength values for various modes of RAVIS transmission (broadcasting band, channel bandwidth, modulation type, code rate) and various types of reception (fixed, portable indoor and outdoor, portable handheld indoor and outdoor, mobile).

9.9 MediaFLO

These details are given for historical completeness only.

The **Forward Link Only (FLO)** multimedia broadcast mobile technology was designed for the delivery of high-quality entertainment and information, including streaming video and audio, “clipcasting” media, IP datacasting and interactive services.

FLO technology is included in Recommendation ITU-R BT.1833 [9.35] designated as ITU-R Multimedia System M.

The MediaFLO system was withdrawn by its proponents and all services ceased as of March 2011.

Bibliography to Chapter 9

- [9.1] **ITU-R**, Recommendation ITU-R BT.1209-1, *Service multiplex methods for digital terrestrial television broadcasting*
- [9.2] **ITU-R**, Recommendation ITU-R BT.1869, *Multiplexing scheme for variable-length packets in digital multimedia broadcasting systems*
- [9.3] **ITU-R**, Recommendation ITU-R BT.1437, *User requirements for digital coding for multi-programme television transmission*
- [9.4] **ITU-T**, Recommendation ITU-T J.180, *User requirements for statistical multiplexing of several programmes on a transmission channel*
- [9.5] **EBU** Technical Report 35, *An Introduction to Time Frequency Slicing*
- [9.6] **ITU-T**, Recommendation ITU-T H.222.0, *Information technology – Generic coding of moving pictures and associated audio information: Systems*
- [9.7] **ISO/IEC** 13818-1 – *Information technology – Generic coding of moving pictures and associated audio information: Systems*
- [9.8] **ETSI** EN 302 755 v.1.3.1 – *Digital Video Broadcasting (DVB); Frame structure channel coding and modulation for a second generation digital terrestrial television broadcasting system (DVB-T2)*
- [9.9] **ITU-R**, Recommendation ITU-R BO.1784, *Digital satellite broadcasting system with flexible configuration (television, sound and data)*
- [9.10] **ITU-R**, Recommendation ITU-R BT.1207, *Data access methods for digital terrestrial television broadcasting*
- [9.11] **ITU-R**, Recommendation ITU-R BT.1300-3, *Service multiplex, transport, and identification methods for digital terrestrial television broadcasting*
- [9.12] **ISO/IEC** 23008-1 – *High efficiency coding and media delivery in heterogeneous environments – Part 1: MPEG media transport (MMT)*
- [9.13] **ITU-R**, Report ITU-R BT.1223, *A layered model approach for digital television*
- [9.14] **ITU-R**, Recommendation ITU-R BT.1434, *Network independent protocols for interactive systems*
- [9.15] **ITU-R**, Recommendation ITU-R BT.807, *Reference model for data broadcasting*
- [9.16] **ISO** 7498-1 *Information technology – Open Systems Interconnection – Basic Reference Model: The Basic Model*
- [9.17] **ITU-R**, Report ITU-R BT.2342, *Production, emission and exchange of closed captions for all worldwide language character sets (latin and non-latin)*
- [9.18] **ITU-R**, Recommendation ITU-R BT.653, *Teletext systems*
- [9.19] **ITU-R**, Recommendation ITU-R BT.470, *Conventional analogue television systems*
- [9.20] **ITU-R**, Recommendation ITU-R BT.1301, *Data services in digital television broadcasting*
- [9.21] **ETSI** EN 300 472 – *Digital Video Broadcasting (DVB); Specification for conveying ITU-R System B Teletext in DVB bitstreams*
- [9.22] **ISO/IEC** 13818-6: *Information technology – Generic coding of moving pictures and associated audio information – Part 6: Extensions for DSM-CC*
- [9.23] **ITU-R**, Recommendation ITU-R BT.2054, *Multiplexing and transport schemes in multimedia broadcasting systems for mobile reception*
- [9.24] **ITU-R**, Recommendation ITU-R BT.1887, *Carriage of IP packets in MPEG 2 transport streams in multimedia broadcasting*

- [9.25] **ITU-R**, Recommendation ITU-R BT.1299, *The basic elements of a worldwide common family of systems for digital terrestrial television broadcasting*
- [9.26] **CENELEC** EN 50083-9 Cabled distribution systems for television, sound and interactive multimedia signals Part 9: Interfaces for CATV/SMATV headends and similar professional equipment for DVB/MPEG-2 transport streams
- [9.27] **ITU-R**, Recommendation ITU-R BT.1436, *Transmission systems for interactive cable television services*
- [9.28] **ITU-T**, Recommendation ITU-T J.112, *Transmission systems for interactive cable television services*
- [9.29] **ETSI** EN 301 192 – *Digital Video Broadcasting (DVB); DVB specification for data broadcasting*
- [9.30] **ETSI** TR 101 202 – *Digital Video Broadcasting (DVB); Implementation guidelines for Data Broadcasting*
- [9.31] **ARIB** STD-B24 – *Data coding and transmission specification for digital broadcasting. Association of Radio Industries and Businesses*
- [9.32] **ITU-R**, Recommendation ITU-R BT.956, *Data broadcasting systems: Signal and service quality field trials and theoretical studies*
- [9.33] **ITU-R**, Recommendation ITU-R BT.1306, *Error-correction, data framing, modulation and emission methods for digital terrestrial television broadcasting*
- [9.34] **ITU-R**, Recommendation ITU-R BT.1877, *Error-correction, data framing, modulation and emission methods for second generation of digital terrestrial television broadcasting systems*
- [9.35] **ITU-R**, Recommendation ITU-R BT.1833, *Broadcasting of multimedia and data applications for mobile reception by handheld receivers*
- [9.36] **ETSI** EN 300 744 – *Digital Video Broadcasting (DVB); Framing structure, channel coding and modulation for digital terrestrial television*
- [9.37] **ETSI** EN 301 701 – *Digital Video Broadcasting (DVB); OFDM modulation for microwave digital terrestrial television*
- [9.38] **ITU-R**, Recommendation ITU-R BS.1114, *Systems for terrestrial digital sound broadcasting to vehicular, portable and fixed receivers in the frequency range 30-3 000 MHz*
- [9.39] **IETF** RFC 3926 FLUTE – *File Delivery over Unidirectional Transport*
- [9.40] **IETF** RFC 3095 – *RObust Header Compression (ROHC): Framework and four profiles: RTP, UDP, ESP, and uncompressed*
- [9.41] **IETF** RFC 4326 – *Unidirectional Lightweight Encapsulation (ULE) FOFor transmission of IP datagrams over an MPEG-2 Transport Stream (TS)*
- [9.42] **ITU-R**, Recommendation ITU-R BT.1368, *Planning criteria, including protection ratios, for digital terrestrial television services in the VHF/UHF bands*
- [9.43] **ITU-R**, Report ITU-R BT.2295-1, *Digital terrestrial broadcasting systems*
- [9.44] **ITU-R**, Recommendation ITU-R BS.1660, *Technical basis for planning of terrestrial digital sound broadcasting in the VHF band*
- [9.45] **Chinese National Standard** GB20600-2006 – *Framing structure, channel coding and modulation for digital television terrestrial broadcasting system*
- [9.46] **Chinese National Standard** GD/J 068-2015 – *Frame Structure, Channel Coding and Modulation for Digital Television/Terrestrial Multimedia Broadcasting-Advanced (DTMB-A)*
- [9.47] **Radio Television Hong Kong et al.** – *Field test report of Evolution System for DTMB* – Available at http://www.ofca.gov.hk/filemanager/ofca/en/content_669/tr201307_01.pdf
- [9.48] **ATSC** Standard A/53, Part 1:2013, *Digital Television System*

- [9.49] **ATSC** Standard A/53, Part 2:2011, *RF/Transmission System Characteristics*
- [9.50] **ATSC** Standard A/53, Part 3:2013, *Service Multiplex and Transport Subsystem Characteristics*
- [9.51] **ATSC** Standard A/53, Part 4:2009, *MPEG-2 Video System Characteristics*
- [9.52] **ATSC** Standard A/53, Part 5:2014, *AC-3 Audio System Characteristics*
- [9.53] **ATSC** Standard A/53, Part 6:2013, *Enhanced AC-3 Audio System Characteristics*
- [9.54] **ATSC** Standard A/153 Part 1:2013, *ATSC Mobile DTV System*
- [9.55] **ATSC** Standard A/153 Part 2:2011, *RF/Transmission System Characteristics*
- [9.56] **ATSC** Standard A/153 Part 3:2013, *Service Multiplex and Transport Subsystem Characteristics*
- [9.57] **ATSC** Standard A/153 Part 4:2009, *Announcement*
- [9.58] **ATSC** Standard A/153 Part 5:2009, *Application Framework*
- [9.59] **ATSC** Standard A/153 Part 6:2011, *Service Protection*
- [9.60] **ATSC** Standard A/153 Part 7:2012, *AVC and SVC Video System Characteristics*
- [9.61] **ATSC** Standard A/153 Part 8:2012, *HE AAC Audio System Characteristics*
- [9.62] **ATSC** Standard A/153 Part 9:2013, *Scalable Full Channel Mobile Mode*
- [9.63] **ATSC** Standard A/153 Part 10:2013, *Mobile Emergency Alert System*
- [9.64] **ATSC** Standard A/110:2011, *ATSC Standard for Transmitter Synchronization*
- [9.65] **ATSC** Recommended Practice A/74:2010, *Receiver Performance Guidelines*
- [9.66] **ATSC** Recommended Practice A/174:2011, *Mobile Receiver Performance Guidelines*
- [9.67] **ATSC** Standard A/107:2015, *ATSC 2.0 Standard*
- [9.68] **ATSC** Standard A/103:2014, *Non-Real-Time Delivery*
- [9.69] **ATSC** Standard A/105:2015, *Interactive Services*
- [9.70] **Richer, Mark S.** Next Generation DTV: ATSC 3.0., 2015, *ITU International Symposium on the Digital Switchover*. –Available at https://www.itu.int/en/ITU-R/GE06-Symposium-2015/Session4/402%20%20Richer_ATSC%203_ITU%20Symp.pdf
- [9.71] **ENENSYS** Benefits of using multiple PLP in DVB-T2 Available at <http://www.enensys.com/documents/whitePapers/ENENSYS%20Technologies%20-%20Benefits%20of%20using%20multiple%20PLP%20in%20DVB-T2.pdf>
- [9.72] **DVB** India Launches Free DVB-T2 Mobile TV Service – Available at <https://www.dvb.org/news/india-launches-free-dvb-t2-mobile-tv-service/country/india>
- [9.73] **DVB** Digital Video Broadcasting (DVB); Next Generation broadcasting system to Handheld, physical layer specification (DVB-NGH) DVB Document A160
- [9.74] **ITU-R**, Report ITU-R BT.2139, *Diversity reception of digital terrestrial television broadcasting signals*
- [9.75] **ITU-R**, Recommendation ITU-R BT.2074-0, *Service configuration, media transport protocol, and signalling information for MMT-based broadcasting systems*
- [9.76] **ISO/IEC** 13818-11:2004 – *Information technology – Generic coding of moving pictures and associated audio information – Part 11: IPMP on MPEG-2 systems*
- [9.77] **ETSI** TS 102 823 – *Digital Video Broadcasting (DVB); Specification for the carriage of synchronized auxiliary data in DVB transport streams*

- [9.78] **ETSI TS 102 006** – *Digital Video Broadcasting (DVB); Specification for System Software Update in DVB Systems.*
- [9.79] **ETSI EN 300 743** – *Digital Video Broadcasting (DVB); Subtitling systems*
- [9.80] **UPnP Forum** UPnP Device Architecture v1.1, October 2008.
- [9.81] **UPnP Forum** <http://www.upnp.org/> As of January 1, 2016 the UPnP Forum is now included in the Open Connectivity Foundation (OCF). See: <http://openconnectivity.org/upnp>
- [9.82] **ISO/IEC 29341-1** – *UPnP Device Architecture Version 1.0*, November 2008.
- [9.83] **Sattler, Fabian** Interoperabilitätstests vernetzter Multimediakomponenten auf Basis von UPnP A/V/DLNA zur Übertragung von Rundfunkinhalten im Heimnetzwerk, Diplomarbeit Hochschule Deggendorf für angewandte Wissenschaften, Fakultät Elektro- und Medientechnik; June 2010 – available in German only.
- [9.84] **IETF** Simple Service Discovery Protocol/1.0. October 1999, ftp://ftp.pwg.org/pub/pwg/ipp/new_SSDP/draft-cai-ssdp-v1-03.txt
- [9.85] **Multimedia over Coax Alliance** The Standard for Home Entertainment Networks over Coax. November 2009 Available at http://www.mocalliance.org/industry/brochure/MoCA_Brochure.pdf.
- [9.86] **ETSI TS 102 771** – *Digital Video Broadcasting (DVB); Generic Stream Encapsulation (GSE) implementation guidelines*
- [9.87] **ETSI TR 102 831** – *Digital Video Broadcasting (DVB); Implementation guidelines for a second generation digital terrestrial television broadcasting system (DVB-T2)*
- [9.88] **ATSC A/58** – *Recommended practice; Harmonization with DVB SI in the use of the ATSC digital television standard*
- [9.89] **ATSC Standard A/65B** – *Program and system information protocol for terrestrial broadcast and cable Revision B*
- [9.90] **ATSC Standard A/53C** – *Digital television standard Revision C*, including Amendment No. 1 (July 2004) and Corrigendum No. 1 (March 2005)
- [9.91] **ATSC Recommended practice A/58** – *Harmonization with DVB SI in the use of the ATSC digital television standard*
- [9.92] **ATSC Recommended Practice A/54A** – *Guide to the use of the ATSC digital television standard*
- [9.93] **ETSI TS 101 162** – *Digital video broadcasting (dvb); allocation of service information (si) codes for digital video broadcasting (dvb) systems*
- [9.94] **ETSI ETS 300 468** – *Digital video broadcasting (dvb); specification for Service Information (SI) in dvb systems*
- [9.95] **ETSI TR 101 211** – *Digital video broadcasting (dvb); guidelines on implementation and usage of dvb service information*
- [9.96] **ETSI TS 101 154** – *Digital Video Broadcasting (DVB); Specification for the use of Video and Audio Coding in Broadcasting Applications based on the MPEG-2 Transport Stream*
- [9.97] **ARIB STD-B10** – *Service information for digital broadcasting system*
- [9.98] **ARIB STD-B32** – *Video coding, audio coding and multiplexing specifications for digital broadcasting*
- [9.99] **ARIB TR-B14** – *Operational guidelines for digital terrestrial television broadcasting*
- [9.100] **ATSC** – *Standard A/90 ATSC data broadcast standard*
- [9.101] **ARIB B24** – *Data Coding and Transmission Specification for Digital Broadcasting*

- [9.102] **ITU-R** Recommendation ITU-R BT.2055 – *Content elements in multimedia broadcasting systems for mobile reception*
- [9.103] **ETSI** EN 302 583 – *Digital Video Broadcasting (DVB); Framing Structure, channel coding and modulation for Satellite Services to Handheld devices (SH) below 3 GHz*
- [9.104] **ETSI** TS 102 585 – *Digital Video Broadcasting (DVB); System Specifications for Satellite services to Handheld devices (SH) below 3 GHz*
- [9.105] **ETSI** TS 102 470-2 – *Digital Video Broadcasting (DVB); IP Datacast: Program Specific Information (PSI)/Service Information (SI); Part 2: IP Datacast over DVB-SH*
- [9.106] **ETSI** TS 102 584 – *Digital Video Broadcasting (DVB); Guidelines for Implementation for Satellite Services to Handheld devices (SH) below 3GHz*
- [9.107] **ETSI** TS 102 585 – *Digital Video Broadcasting (DVB); System Specifications for Satellite services to Handheld devices (SH) below 3 GHz*
- [9.108] **ETSI** TS 102 592-2 – *Digital Video Broadcasting (DVB); IP Datacast: Electronic Service Guide (ESG); Implementation Guidelines; Part 2: IP Datacast over DVB-SH*
- [9.109] **ETSI** TS 102 611-2 – *Digital Video Broadcasting (DVB); IP Datacast: Implementation Guidelines for Mobility; Part 2: IP Datacast over DVB-SH (see part 1 in DVB-H references)*
- [9.110] **ETSI** TS 102 772 – *Digital Video Broadcasting (DVB); Specification of Multi-Protocol Encapsulation – inter-burst Forward Error Correction*
- [9.111] **ETSI** EN 302 304 – *Digital Video Broadcasting (DVB); Transmission System for Handheld Terminals (DVB-H)*
- [9.112] **ITU-R**, Report ITU-R BT.2049, *Broadcasting of multimedia and data applications for mobile reception*
- [9.113] **ITU-R**, Report ITU-R BS.2214, *Planning parameters for terrestrial digital sound broadcasting systems in VHF bands*
- [9.114] **ETSI** TR 102 377 – *Digital Video Broadcasting (DVB); Implementation guidelines for DVB handheld services*
- [9.115] **ITU-R**, Report ITU-R BT.2254, *Frequency and network planning aspects of DVB-T2*
- [9.116] **ITU-R**, Report ITU-R BT.2343, *Collection of field trials of UHDTV over DTT networks*
- [9.117] **Greene, K.** DVB-T2-Lite profile tech standard approved: Transmissions are go! Available at <http://www.bbc.co.uk/blogs/researchanddevelopment/2011/07/dvb-t2-lite-profile-tech-stand.shtml>
- [9.118] **ETSI** TS 102 428 – *Digital Audio Broadcasting (DAB); DMB video service; User Application Specification*
- [9.119] **ITU-R**, Recommendation ITU-R BT.2016, *Error-correction, data framing, modulation and emission methods for terrestrial multimedia broadcasting for mobile reception using handheld receivers in VHF/UHF bands*
- [9.120] **ETSI** TS 102 427 – *Digital Audio Broadcasting (DAB); Data Broadcasting – MPEG-2 TS Streaming*
- [9.121] **ETSI** EN 300 401 – *Radio Broadcasting Systems; Digital Audio Broadcasting (DAB) to mobile, portable and fixed receivers*
- [9.122] **ISO/IEC** 14496-3 – *Information Technology – Coding of audio-visual objects: Part 3: Audio*
- [9.123] **ITU-T**, Recommendation ITU-T H.264, *ISO/IEC 14496-10: Information Technology – Coding audio-visual objects: Part 10: Advanced Audio Coding*
- [9.124] **ISO/IEC** 14496-1 – *Information technology Coding of audio-visual objects Part 1: Systems*

- [9.125] **ITU-R**, Recommendation ITU-R BS.1114, *Systems for terrestrial digital sound broadcasting to vehicular, portable and fixed receivers in the frequency range 30-3 000 MHz System A*
- [9.126] **ETSI** ES 201 980 – *Digital Radio Mondiale (DRM); System Specification*
- [9.127] **ITU-R**, Report ITU-R BT.1210, *Error-protection strategies for data broadcasting services*
- [9.128] **ITU-R**, Report ITU-R BT.1225, *Data broadcasting systems and services in an HDTV environment*
- [9.129] **ETSI** TS 102 606 – *Digital Video Broadcasting (DVB); Generic Stream Encapsulation (GSE) Protocol*
- [9.130] **CENELEC** EN 50221 – *Common Interface Specification for Conditional Access and other Digital Video Broadcasting Decoder Applications*
- [9.131] **ETSI** TS 101 699 – *Digital Video Broadcasting (DVB); Extensions to the Common Interface Specification*
- [9.132] **ETSI** TR 101 891 – *Digital Video Broadcasting (DVB); Professional Interfaces: Guidelines for the implementation and usage of the DVB Asynchronous Serial Interface (ASI)*
- [9.133] **ITU-R**, Recommendation ITU-R BT.1206, *Spectrum shaping limits for digital terrestrial television broadcasting*
- [9.134] **ITU-R**, Recommendation ITU-R BT.1208, *Video coding for digital terrestrial television broadcasting*
- [9.135] **ITU-R**, Recommendation ITU-R BS.1115, *Low bit-rate audio coding*
- [9.136] **ITU-R**, Recommendation ITU-R BT.1699, *Harmonization of declarative application formats for interactive TV*
- [9.137] **ITU-R**, Recommendation ITU-R BT.1774, *Use of satellite and terrestrial broadcast infrastructures for public warning, disaster mitigation and relief*
- [9.138] **ITU-R**, Report ITU-R BT.2035, *Guidelines and techniques for the evaluation of digital terrestrial television broadcasting systems including assessment of their coverage areas*
- [9.139] **ITU-R**, Report ITU-R BT.2075, *Protection requirements for terrestrial television broadcasting services in the 620-790 MHz band against potential interference from GSO and non-GSO broadcasting-satellite systems and networks*
- [9.140] **ITU-R**, Recommendation ITU-R BT.1735 (08/05), *Methods for objective quality coverage assessment of digital terrestrial television broadcasting signals of System B specified in Recommendation ITU-R BT.1306*
- [9.141] **ITU-R**, Recommendation ITU-R SM.1541 (2011-09), *Unwanted emissions in the out-of-band domain*
- [9.142] **ITU-R**, Recommendation ITU-R SM.1792 (2007-02), *Measuring sideband emissions of T-DAB and DVB-T transmitters for monitoring purposes*
- [9.143] **ITU-R**, Recommendation ITU-R SM.1875 (2010-04), *DVB T coverage measurements and verification of planning criteria*
- [9.144] **ITU-R**, Report ITU-R BT.2137 (2008), *Coverage prediction methods and planning software for digital terrestrial television broadcasting (DTTB) networks*
- [9.145] **ITU-R**, Report ITU-R BT.2138 (2008-11), *Radiation pattern characteristics of UHF television receiving antennas*
- [9.146] **ITU-R**, Report ITU-R BT.2143-2 (2010-10), *Boundary coverage assessment of digital terrestrial television broadcasting signals*
- [9.147] **ITU-R**, Report ITU-R BT.2215-1(2011-10), *Measurements of Protection Ratios and Overload Thresholds for Broadcast TV Receivers*

- [9.148] **ITU-R**, Report ITU-R BT.2247(2011-10), *Field measurement and analysis of compatibility between DTTB and IMT*
- [9.149] **ITU-R**, Report ITU-R BT.2248(2011-10), *A conceptual method for the representation of loss of broadcast coverage*
- [9.150] **ETSI TS 102 773** – *Digital Video Broadcasting (DVB); Modulator Interface (T2-MI) for a second generation digital terrestrial television broadcasting system (DVB-T2)*
- [9.151] **ETSI EN 302 307** – *Second Generation Framing Structure, Channel Coding and Modulation Systems for Broadcasting, Interactive Services, News Gathering and other Broadband Satellite Applications*
- [9.152] **ITU-R 2140** – *Transition from analogue to digital terrestrial broadcasting*
- [9.153] Balyar, V., Gofaizen, O. *Performance comparison of digital terrestrial television systems in DVB-T/DVB-T2 standards*. – Digital Technologies. – 17 p. – 2012.
- [9.154] ETSI TR 101 497 – *Digital Audio Broadcasting (DAB); Rules of Operation for the Multimedia Object Transfer Protocol*
- [9.155] ETSI TS 101 759 – *Digital Audio Broadcasting (DAB); Data Broadcasting – Transparent Data Channel (TDC)*
- [9.156] ETSI ES 201 735 – *Digital Audio Broadcasting (DAB); Internet Protocol (IP) Datagram Tunnelling*
- [9.157] ETSI TS 101 499 – *Digital Audio Broadcasting (DAB); MOT Slide Show; User Application Specification*
- [9.158] ETSI TS 101 498-1 – *Digital Audio Broadcasting (DAB); Broadcast Website; Part 1: User Application Specification*
- [9.159] ETSI TS 101 498-2 – *Digital Audio Broadcasting (DAB); Broadcast Website; Part 2: Basic Profile Specification*
- [9.160] ETSI EN 301 234 – *Digital Audio Broadcasting (DAB); Multimedia Object Transfer (MOT) Protocol*
- [9.161] ETSI TS 102 371 – *Digital Audio Broadcasting (DAB); Transportation and Binary Encoding Specification for DAB Electronic Programme Guide (EPG)*
- [9.162] ETSI TS 102 818 – *Digital Audio Broadcasting (DAB); XML Specification for DAB Electronic Programme Guide (EPG)*
- [9.163] Telecommunications Technology Association of Korea TTA.KO-07.0070 – *Specification of the Advanced Terrestrial Digital Multimedia Broadcasting (AT-DMB) to mobile, portable and fixed reception*
- [9.164] **Kim, K.-Y., Lee, G.S., Lim, J.S., Lee, S.I., and Kim, D.G.** *Efficient Generation of Scalable Transport Stream for High Quality in T-DMB Service* ETRI Journal, vol.31, no.1: Feb. 2009, pp.65-67
- [9.165] **IEEE Transactions on Broadcasting: Field Trials for Terrestrial Digital Multimedia Broadcasting System (T-DMB)** Jan. 2007
- [9.166] ETSI TS 101 190 – *Digital Video Broadcasting (DVB); Implementation guidelines for DVB terrestrial services; Transmission aspects*
- [9.167] ETSI TS 101 191 – *Digital Video Broadcasting (DVB); DVB mega-frame for Single Frequency Network (SFN) synchronization*
- [9.168] Le Floch, B., Alard, M., and Berrou, C. *Coded Orthogonal Frequency Division Multiplex* Proc. IEEE, vol. 83, no. 6, June 1986, pp. 587–592
- [9.169] Abdel Nour, C. and Douillard, C. *Rotated QAM Constellations to Improve BICM Performance for DVB-T2* Proc. ISSSTA, Aug. 2008, pp. 354–59

- [9.170] Han, S.H. and Lee, J.H. *An Overview of Peak-to-Average Power Ratio Reduction Techniques for Multicarrier Transmission* IEEE Wireless Commun., vol. 12, no. 2, Apr. 2005, pp. 56–65
- [9.171] Mignone, V. and Morello, A. *CD3-OFDM: A Novel Demodulation Scheme for Fixed and Mobile Receivers* IEEE Trans. Commun., vol. 44, no. 9, Sept. 1996, pp. 1144–51
- [9.172] Alamouti, S.M. – *A Simple Transmit Diversity Technique for Wireless Communications* IEEE JSAC, vol. 16, no. 8, Oct. 1998, pp. 1451–58
- [9.173] www.igorfun.com/dvb-t/
- [9.174] **Chinese National Standard** GB/T2666-2011 – *Implementation Guidelines for transmission system of digital terrestrial television broadcasting*

CHAPTER 10

Interactivity and collaboration between DTTB and non-broadcasting systems

10.1 General aspects and opportunities of collaboration

Historically, television was a receive-only service, and the TV set was used to display the TV image and sound as well as (from the 1980s onwards) additional data such as teletext. With the advent of digital and computational technologies, TV sets extended their capabilities to become a more general user interface for selecting and retrieving content.

Different media such as television broadcasting and bi-directional telecommunication networks have collaborated for many years. Such collaboration does not mean replacement of one network by the other; rather, it creates an environment in which both systems can co-exist independently or cooperatively.

In ITU-R terms, broadcasting is a medium that delivers unidirectional information such as image, sound and data to the general public (Radio Regulations 1.38). A telecommunication service, on the other hand, provides personalized delivery of data requested by the users or, by extension, their media systems.

Collaboration of telecommunication and broadcasting services allows the possibility of interaction and personalization. Nowadays, consumers expect this to be available irrespective of user location ('any place') and at any moment of time ('any time'). Consequently, for interactivity, modern TV sets can be connected to a telecommunications network, normally an IP network, in addition to the broadcasting network.

10.2 Collaboration at the service layer

Service layer collaboration appears when broadcast and IP content are interlinked, such as when additional information to a broadcast signal is streamed over the Internet. A typical application of this is the interactive broadcast-broadband (IBB) systems described in section 10.2.1.

Collaboration at the service layer has become a common feature of both telecommunication and broadcasting development. This is to some extent associated with the fact that many users wish to have an application where multiple different services, e.g. television broadcasting and multimedia applications, are provided.

10.2.1 Integrated Broadcast-Broadband

One type of service collaboration is IBB technology where broadcast content is transmitted over a unidirectional broadcast network and additional (often multimedia) content is received over bi-directional broadband networks. It maximizes the user experience by providing high quality, flexible, interactive and personalized services such as additional information about television programmes (for example, an EPG), or additional services for minorities and people with special needs, etc. One of the main attractions is non-linear broadcasting, i.e. to watch missed programmes ('catch-up TV').

Most current TV sets are equipped with TV tuners for one or more types of broadcast distribution (cable, satellite and terrestrial) and provide interfaces for IP networks (WLAN, Ethernet, etc.).

Two main ITU-R documents on current IBB systems are published:

- Recommendation ITU-R BT.2075-0 [10.1] "Integrated broadcast-broadband system";
- Report ITU-R BT.2267-5 [10.2] "Integrated broadcast-broadband systems".

In these documents, the following IBB systems are described:

- HbbTV (Hybrid broadcast broadband television);
- Hybridcast;
- HTML5 based Smart TV Platform;

- Integrated broadcast-broadband system based on the Ginga middleware; and
- Integrated broadcast-broadband system based on enhancement of data broadcasting.

HbbTV (Hybrid Broadcast Broadband TV) is an ETSI standard providing an open and business neutral technology platform that seamlessly combines TV services delivered via broadcast with services delivered via broadband and also enables access to internet-only services for consumers using connected TVs and set-top boxes. The HbbTV specification is based on existing standards and web technologies including OIPF (Open IPTV Forum), CEA, DVB and W3C. The standard provides the features and functionality required to deliver feature rich broadcast and internet services. Utilizing standard internet technology, it enables rapid application development. It defines minimum requirements simplifying the implementation in devices and leaving room for differentiation – this limits the investment required by CE manufacturers to build compliant devices.

Amongst other new features, adaptive streaming (in line with MPEG-DASH) is supported. Version 2.0 based on HTML5 has now been published.

Hybridcast, an IBB system that uses HTML5, was standardized in Japan in versions 1.0 and 2.0 in March, 2013 and June, 2014 respectively. The system facilitates the offering of services through a combination of broadcast and broadband telecommunication resources and features. The latest specifications considered most of the requirements in Recommendations ITU-R BT.2053 [10.3] and ITU-T J.205 [10.4] including broadcast centric scenario. Hybridcast supports HTML-5, MPEG-DASH, MMT protocol and others.

HTML5 based Smart TV Platform is an open smart TV platform standard that specifies the web runtime environments for smart TV application based on state-of-the-art HTML5 technologies. An application in compliance with this specification can be developed and deployed taking advantage of HTML5 features and interfaces, and will provide the same user experience on smart TV receivers from various broadcasting systems like terrestrial, cable, satellite and IPTV.

Ginga provides support to collaborative services by making use of broadcast and IP distribution path. Ginga is a dynamic environment that supports different interactive TV protocols.

IBB system based on enhancement of data broadcasting is a classical interactive system. For interactive data delivery, the broadcast channel is used. Because the broadcast channel is unidirectional, all the interactive and non-interactive TV content has to be delivered together simultaneously. A receiver selects the required elements from the delivered data according to the end-users' instruction for presentation. Content elements that can be delivered are sometimes limited by the available broadcast transmission bandwidth. So such content elements are delivered over a broadband channel like the Internet.

10.2.2 Middleware

Middleware is software linked to the “operating system” of a TV set. It allows the creation of an environment for consumers to make use of software applications provided via the broadcast signal but, mostly, via an IP connection. It provides the possibility to retrieve, consume, store, edit and create additional content by simple interaction of the broadcast and non-broadcast environments, as well enabling social networking.

Some of the early systems making use of middleware are MHP/GEM and MHEG-5. More recent systems make use of a middleware that supports the IBB systems described above. Nowadays, such middleware is usually an integral part of any connected TV set.

Further information on middleware implementations is given in Chapter 13.

10.3 Technical commonalities

Technologies which are common to telecommunication and broadcasting facilitate the interworking between these systems, e.g. by the use of common video coding schemes. This allows effective interaction at different layers – physical, link, application layers, etc., between different systems (e.g. LTE and DTTB).

10.4 Collaboration at the network level

Delivery of broadcast content via a broadcast network (DTTB) and via non-broadcast network (e.g. eMBMS) may or may not be under the control of the same entity. Depending on the location of the desired content (within either the broadcast or the IP signal), the terminal used by a consumer switches to the respective network (see Figure 10.1). Alternatively, broadcast content may be simulcast in both a DTTB and an IP network (such as LTE) to allow reception in areas where either the broadcast or IP signal cannot be received adequately.

The control network procedure may be complicated with respect to regulatory, economical and/or technical issues, especially in the case of different service and network operators of the broadcasting and non-broadcasting network.

FIGURE 10.1
Combined network concept

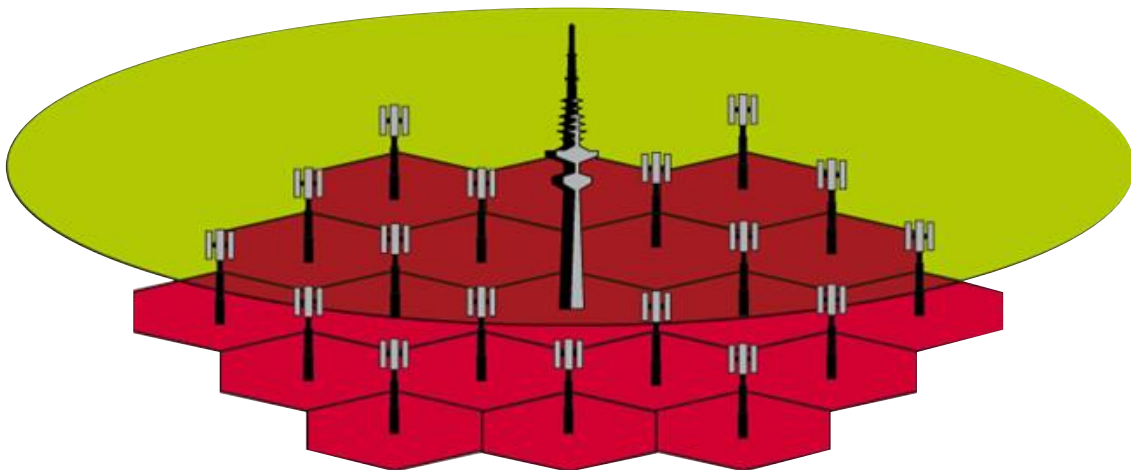

DTTB-10-01

(Diagram courtesy of Technische Universitaet Braunschweig)

More intense forms of network collaboration between the broadcasting and the mobile service may play a bigger role in the future. To date, however, such concepts are still under development.

In particular, the Technical University of Braunschweig (Brunswick, Germany) made substantial investigations in this domain. Two of their concepts are:

- Use of Future Extension Frames (FEFs) of the MPEG-2 Transport Stream: Within the so-called private sections, the MPEG-2 TS allows the introduction of packets that have not yet been identified for specific use in the MPEG-2 TS specification. Such packets should be ignored by existing TV receivers. These unused packets are reserved for future use (the so-called FEFs). The packet of such FEFs could be used to carry broadcast content in LTE mode. The MPEG multiplex would thus carry the broadcast signal twice (in time multiplex): once as conventional programme elements, and once as an IP-based signal. A slightly modified mobile device such as a tablet computer would trigger on these repetitively occurring FEFs and thus extract the broadcast content. The overall capacity is shared between both the conventional broadcast and the LTE-type signal. However, there is, in principle, the possibility of direct reception of the broadcast content with hand-held devices. The system has been demonstrated at laboratory level and at various trade fairs.

- “Tower overlay”: The basic idea is to share dynamically the infrastructure as depicted in Figure 10.1 for the delivery of broadcasting services. Basically, it represents a combined operation of relatively high-powered transmitters in broadcast configuration (large cells serving each a large area of the order of 50-70 km of diameter), and of relatively low-powered base-stations in a mobile network configuration (small cells serving each an area of up to a few kilometres). Programmes that attract a large audience are transmitted via the high-power broadcast network whilst programmes that are followed by a smaller audience make use of the small-cell configuration. The switch may be dynamic with time as audience levels change. The advantage could be some spectrum saving, or in turn, some increased capacity for broadcasting. [10.5].

A technical solution for DTTB reception on smartphones and tablets exists through the use of a DTTB to IP conversion device associated with a Wi-Fi router.

Commercial products are available based on the SAT/IP protocol that distribute DVB-S/S2 services to IP-connected devices using in-home Wi-Fi routers or Ethernet cabling. Some of these devices also work with DVB-T/T2.

An implementation of this technique, based on open source software (different from SAT/IP³⁹) has been demonstrated by EBU at WRC-15. The use of UPnP allows more types of media device to be reached, independent of their operating system. The general principle is illustrated in Figure 10.2. Further information on home networking can be found in Chapter 9.

FIGURE 10.2

Principle of DTT-to-IP conversion for wireless in-house distribution

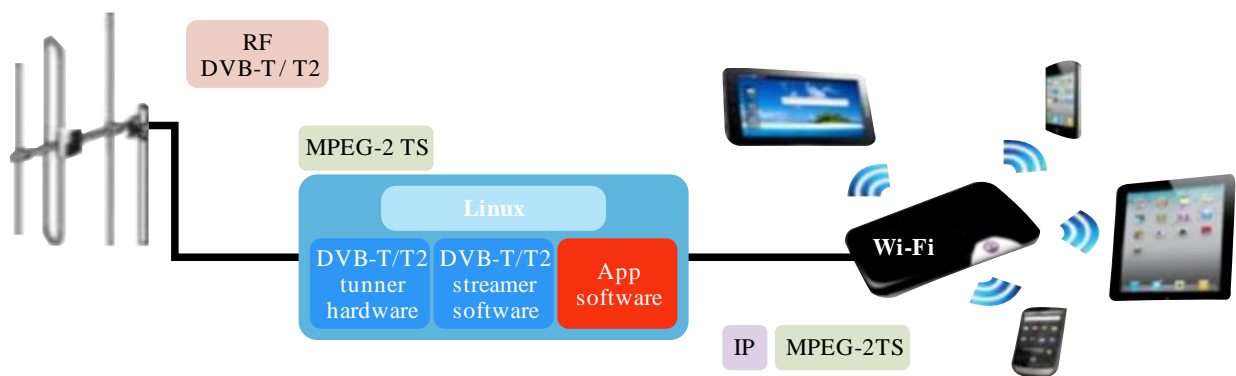

DTTB-10-02

10.5 Detailed discussion on interactive television

10.5.1 Interactivity aspects

The role of interactivity in modern television is continuously increasing, enabled by modern digital telecommunication and television technologies. The interactivity can be provided with different degree of possibilities – from simplest to maximal implementation of interactivity.

Classic interactive applications that worked already in analogue television are teletext, SMS voting, etc. Further development of interactivity in television is the combination of functionalities of digital television and the Internet – integrated broadcast-broadband systems (see section 10.2).

However, such implementation of interactivity is the intermediate stage on the path to “true” interactivity – the interaction of users is limited to transactions with interactive service providers that already have the stable content with which the users will interact. In future, we may consider an extended implementation of

³⁹ SAT/IP also uses UPnP, but proprietary device type information.

interactivity that would allow the end-users to interact with the content produced or create their own content. However, at the time of writing, such extended interactivity is only rarely implemented.

A separate issue is the possibility of technical implementation of a so-called return or interactive channel. In spite of the fact that such technologies were developed some twenty years ago (e.g. DVB-RCT), they did not find wide introduction mainly due to the ubiquitous availability of the Internet via broadband (wired and wireless) networks. Furthermore, a return interactive channel in the terrestrial environment requires the allocation of additional radio frequency resources, which due to presence of a number of radiocommunication services (analogue and digital TV broadcasting, radars, etc.) is quite a complex problem. The experience of the introduction and test results from interactive television technologies (including return interactive channels) for DVB, ATSC and ISDB systems in different countries are provided in [10.3].

10.5.2 Interactive system model

Recommendation ITU-R BT.1369 [10.6] gives general guidance for a worldwide common family of systems for the provision of interactive television services to the public and, in particular, defines a reference model for interactive television. This model is provided in Figure 10.3.

This model foresees the presence of two types of channels: a forward interactive channel, which will be realized on the basis of a broadcast channel, and a return interactive channel which can be realized on the basis of another (often a telecommunication) network (or within the broadcast network with the identification/assignment of certain resources for interactive purposes as described in section 10.5.1).

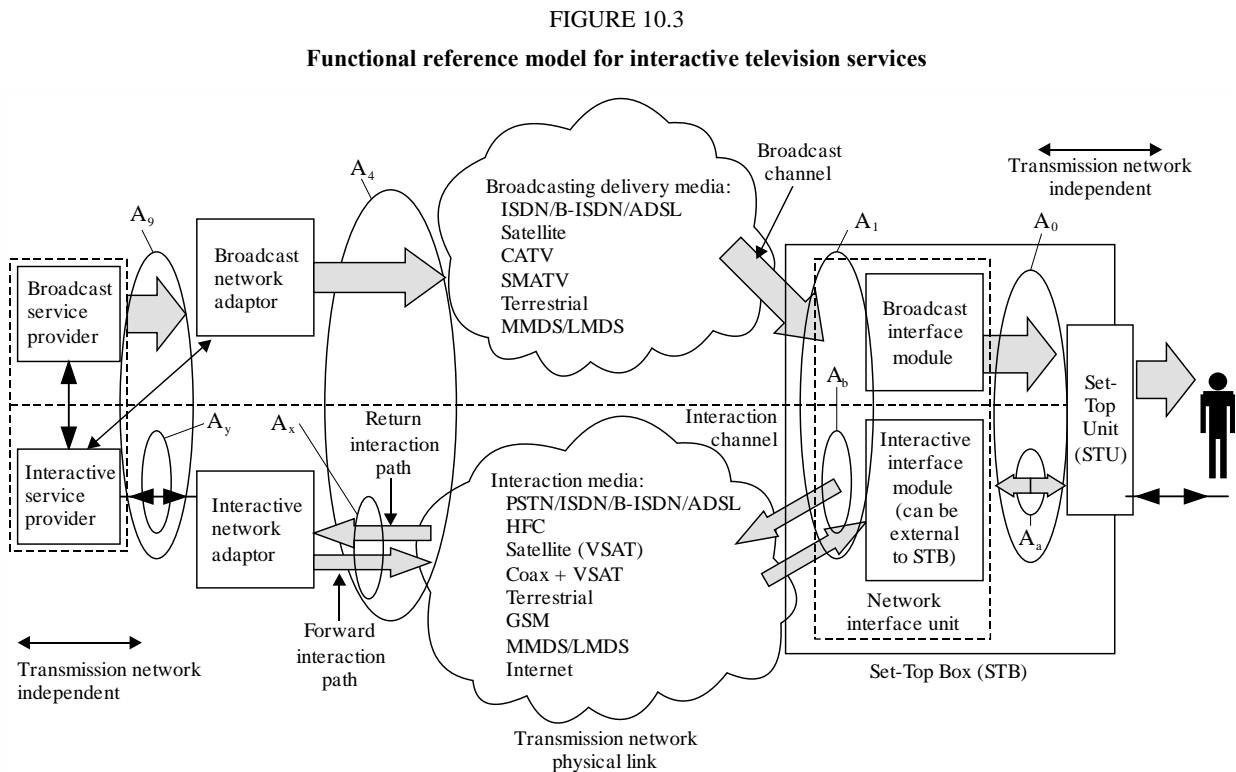

DTTB-10-03

(This model is from 1998 but in its principle, it is still valid. Today, the physical link for the interaction channel is mainly realized by accessing broadband (wired or wireless) IP-based networks.)

Thus, this model allows the interactive environment for interaction of user and interactive service provider to be organized based on different delivery environments – terrestrial, cable and satellite. [10.6] provides a flexible model. At the time of writing, for digital television broadcasting, ITU-R defines certain possibility for the return interactive channel on the basis of PSTN/ISDN networks (Rec. ITU-R BT.1435 [10.7]), DECT (Rec. ITU-R BT.1507 [10.8]), GSM (Rec. ITU-R BT.1508 [10.9]) and LMDS (Rec. ITU-R BT.1564 [10.10])

networks. Model universality is provided thanks to the concept of network independent delivery protocols. The basic principles of the use of such protocols are determined in Recommendation ITU-R BT.1434 [10.11].

For modern IBB systems, the role of the return interaction channel is enhanced to work as the forward interaction channel as well. For example, an interactive application and on-demand content can be delivered from the service providers to a terminal over the return interaction channel. Such usage can be initiated by a user, or as a result of the interaction between the application and the user. This is much more complicated usage of channels. For such complicated usage, Recommendation ITU-R BT.2037 [10.12] defines what an IBB system is and how an IBB system should behave. Recommendation ITU-R BT.2053 [10.3] defines technical requirements of IBB systems highlighting a broadcast centric scenario, which is also based on the enhanced use of the return interaction channel.

10.5.3 Content format for interactive systems

For production and international exchange of interactive multimedia applications, common application formats are defined. Such formats allow the creation of a shared base for organization of content management and exchange in different implementations of interactive system applications by identifying functional commonality among the declarative application environments for interactive TV application specifications ACAP-X, BML and DVB-HTML. Elements which are common to these three standards are identified as a “Common Core”. The value of the Common Core is to assist program authors to exchange declarative applications internationally using these standards.

This Common Core is defined in Recommendation ITU-R BT.1699-2 [10.13]. To allow the possibility of interaction between different interactive platforms, a common instruction set (see Recommendation ITU-R BT.1722-2 [10.14]) and a common application environment for digital interactive television services consisting of basic architecture of the environment, structure of execution engine and the structure of a presentation engine (see Recommendation ITU-R BT.1889 [10.15]) are additionally defined.

For modern IBB systems, Recommendation ITU-R BT.2075 [10.1] provides guidance and technical information for the selection of an appropriate IBB system. Differences and similarities of various aspects of IBB systems such as mono-media, application format, and application types are presented.

10.5.4 Interaction channel for terrestrial environment

For the sake of completeness, reference is made here to the implementation of interactivity via terrestrial return channel. For the DVB area, DVB-RCT is specified as described in Report ITU-R BT.2025 [10.16]. The idea is that the broadcast receiver makes use of its receiving antenna to link back interactive information to the broadcast transmitter. The DVB-RCT frequency synchronization is derived from the broadcast DVB-T signal whilst the time synchronization results from the use of MAC management packets conveyed through the broadcast channel. The principle is shown in Figure 10.4.

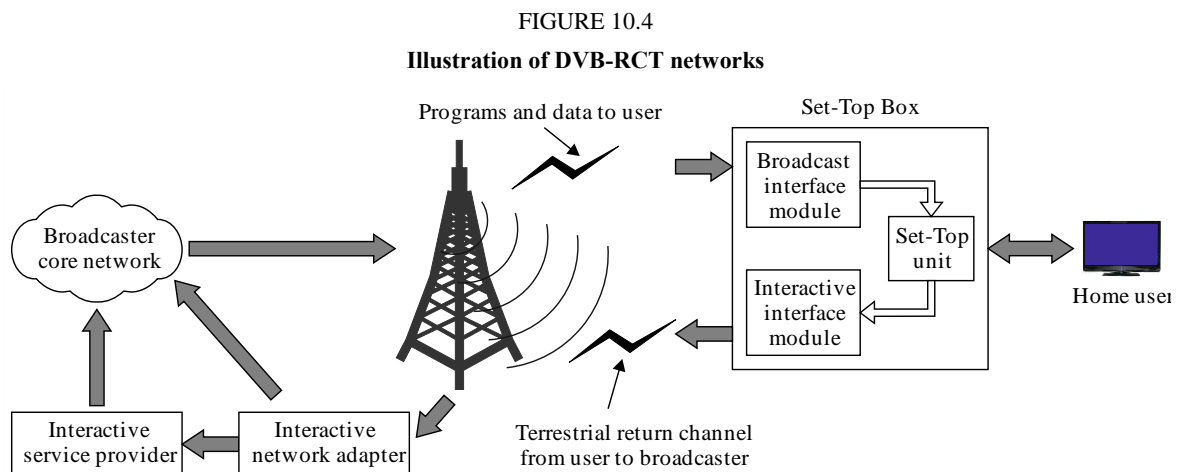

Implementation experience of interactive systems via terrestrial environment is provided in [10.16]. Introduction of such systems foresees the corresponding frequency planning some issues of which are highlighted in Recommendation ITU-R BT.1832 and Report ITU-R BT.2025 [10.17], [10.16].

Bibliography to Chapter 10

- [10.1] Recommendation **ITU-R** BT.2075 – *Integrated broadcast-broadband system*
- [10.2] Report **ITU-R** BT.2267 – *Integrated broadcast-broadband systems*
- [10.3] Recommendation **ITU-R** BT.2053 – *Technical requirements for integrated broadcast-broadband systems*
- [10.4] Recommendation **ITU-T** J.205 – *Requirements for an application control framework using integrated broadcast and broadband digital television*
- [10.5] Ulrich Reimers Dynamic Broadcasting, **EBU** Forecast 2012, ref. <https://tech.ebu.ch/events/forecast12>
- [10.6] Recommendation **ITU-R** BT.1369 – *Basic principles for a worldwide common family of systems for the provision of interactive television services*
- [10.7] Recommendation **ITU-R** BT.1435 – *Digital sound and television broadcasting interaction channel through the PSTN/ISDN*
- [10.8] Recommendation **ITU-R** BT.1507 – *Interaction channel using digital enhanced cordless telecommunications (DECT) system*
- [10.9] Recommendation **ITU-R** BT.1508 – *Interaction channel using global system for mobile communications (GSM)*
- [10.10] Recommendation **ITU-R** BT.1564 – *Interaction channel using local multipoint distribution systems*
- [10.11] Recommendation **ITU-R** BT.1434 – *Network independent protocols for interactive systems*
- [10.12] Recommendation **ITU-R** BT.2037 – *General requirements for broadcast-oriented applications of integrated broadcast-broadband systems and their envisaged utilization*
- [10.13] Recommendation **ITU-R** BT.1699 – *Harmonization of declarative application formats for interactive TV*
- [10.14] Recommendation **ITU-R** BT.1722 – *Harmonization of the instruction set for the execution engine for interactive TV applications*
- [10.15] Recommendation **ITU-R** BT.1889 – *Common application environment for interactive digital broadcasting services*
- [10.16] Report **ITU-R** BT.2025 – *Progress on development and implementation of interactivity in broadcasting systems and services*
- [10.17] Recommendation **ITU-R** BT.1832 – *Digital video broadcast-return channel terrestrial (DVB-RCT) deployment scenarios and planning considerations*

CHAPTER 11

Conditional access and content protection in digital television broadcasting

11.1 General aspects

Many broadcasters see the need for encrypting all or part of their TV programmes. Encryption is a mechanism that allows controlling the reception of TV programmes by authorized users only. This Chapter describes the basic principle of Conditional Access (CA) as well as various Conditional Access Systems (CAS) in use including Digital Rights Management (DRM).

There are two motivations that drive the need for encryption:

- To offer pay TV services;
- To limit the reception to a pre-defined geographical area.

Subscription to Pay TV is usually offered on a yearly, monthly or even hourly (ad-hoc) basis. Especially in the case of ad-hoc access (of a specific film, for example, or a sport event), subscription is often realised via the Internet connection of the smart TV-set. In other cases, software and hardware based CA mechanism are usually applied.

Encryption for geo-blocking is widely known in the case of satellite broadcasting but also finds its use in DTTB to prevent reception of specific TV programme outside a destined service area. Terrestrial geo-blocking may result from a request of the national regulator, it can be the consequence of a non-compete agreement between neighbouring countries, or, most often, be required by the IPR holder of a TV programme when the emitting broadcaster did not or could not acquire the transmission rights for populations outside of a pre-defined service area. In this case, the key for the decryptions is often free-of-charge to the consumers within the intended geographical area.

Encryption may be applied to one or several programmes carried within a TV channel or to the whole multiplex of TV programmes (as illustrated in Figure 11.1). CA may be activated around the clock (“subscription channel”) or during specific time slots only. The technical decryption of a TV programme depends on the CA system used; there are software and hardware based solutions. Software solutions are embedded in the set-top box or TV set while hardware solutions usually rely on a specific interface for a conditional access module (CAM). The most common type of such an interface holds a CI or CI+ module (see sections below).

ITU-studies on technical, operational and other requirements for the conditional access systems (CAS) used in digital television broadcasting systems are carried out in accordance with Study Question ITU-R 49-1/6 [11.1].

Fundamental principles for CAS design of CAS digital broadcasting are defined in Recommendation ITU-R BT.1852 [11.2] and in Report ITU-R BT.1079 [11.3].

The principles described in Recommendation ITU-R BT.1852 should facilitate the development of effective conditional access systems for the Recommendation ITU-T H.222.0 MPEG-2 transport stream (MPEG-2 TS).⁴⁰

⁴⁰ It is expected that, in the future, this Recommendation will also cover the MPEG Media Transport system as defined in Recommendation ITU-R BT.2074 (and already used for 8k UHDTV).

FIGURE 11.1

**Principle block diagram for the usage of CA in DTTB
(example case of encrypting the whole MPEG-2 transport stream)**

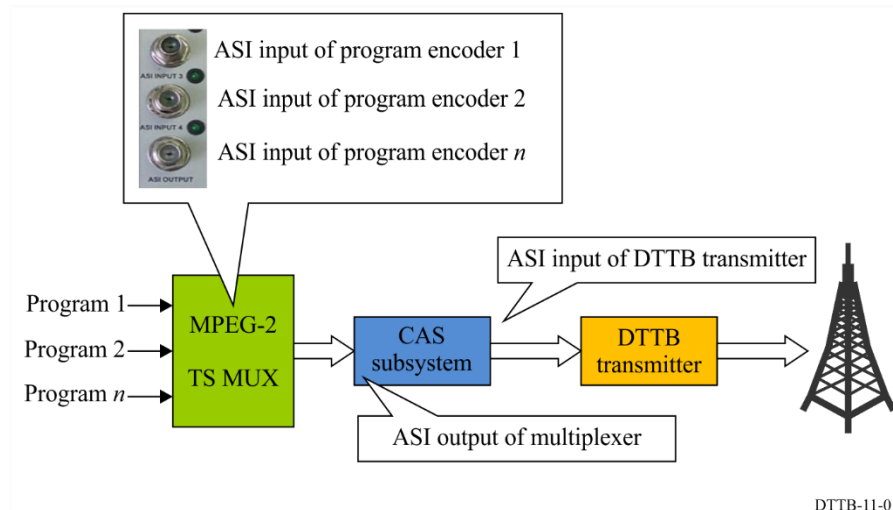

CAS can be implemented either as a separate device following the multiplexer (as shown in Figure 11.1) or as part of certain typical blocks of the digital television transmission side (e.g. at the video/audio encoder or at cable TV head-end station).

At the receiver side, CAS can be implemented by means of a hardware module or as an embedded system. Currently the card systems are widely used in DTTB as the embedded system implementation is more complex to realise for large numbers of subscribers. In embedded systems, the deciphering algorithms are already stored in the receivers. This may be convenient for the consumers, however, adding new algorithms (for example for new service providers), requires downloads to the end-user device which may have limited capacity in terms of the number of algorithms that can be stored.

11.2 Approaches to CAS implementation

For the purpose of providing commonality in terms of the supported CAS, the digital television receivers are often equipped with an interface called Common Interface (CI) or, more recently, CI+ (see section 11.2.3). The goal of the CI implementation is to standardize the format of exchanged CAS messages and common scrambling algorithms. A general block diagram for the usage of the common interface in digital television receivers is provided in Figure 11.2.

FIGURE 11.2
Example of single module in connection with host (see EN 50221)

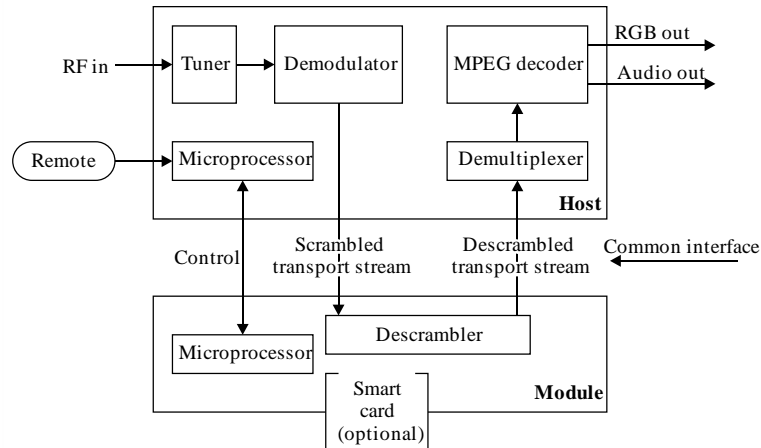

DTTB-11-02

In this Figure, the host is the typical digital television receiver with tuner, demodulator, MPEG decoder, demultiplexer and other blocks used for recovering in television broadcasting programs. The module contains a microprocessor for interoperation with the host blocks, descrambler and optional smart card sub-module. This interaction will be implemented by means of common interface. The communication protocols on this interface are defined in several layers in order to provide the necessary functionality. This functionality includes the ability to support multiple modules on one host, the ability to support complex combinations of transaction between module and host, and an extensible set of functional primitives (objects) which allow the host to provide resources to the module.

11.2.1 CAS for ISDB

CAS specifications for ISDB systems are defined in ARIB STD-B25 [11.6].

This standard applies to all ISDB digital standard television broadcasts, terrestrial and via satellite including high-definition television broadcasts.

ARIB STD-B25 defines the control system for reception (Conditional Access System) and control for playback (Conditional Playback System) used in ISDB system. This standard defines one of possible solutions for CAS but ARIB STD-B25 is considered as main systems.

Main parameters of ARIB STD-B25 system are defined in Recommendation ITU-R BT.1852 [11.2]. CAS for ISDB is referred to as CAS-R system. This system uses cipher for scrambler and descrambler based on MULTI2 (ISO/IEC 9979).

The second-generation CAS is also specified in ARIB STD-B61 [11.7], of which description is shown in Recommendation ITU-R BT.1852 [11.2].

11.2.2 CAS for ATSC⁴¹

ATSC Standard A/70 Part 1 [11.8] defines the CAS for ATSC Terrestrial Broadcasting. This standard defines only building blocks (Simulcrypt, Common scrambling, Host CA Software, Return Channel, and CA Module Interface) necessary to ensure interoperability (that is, any ATSC CA module can operate with any ATSC compatible hosts designed to support ATSC CA). As the ATSC CA module can be designed to be replaceable, ATSC hosts are protected against obsolescence as security is upgraded and this standard can be expected to last as long as the ATSC standard itself does.

ATSC Standard A/70 Part 2 [11.9] defines the method for utilizing Simulcrypt concepts to simultaneously encrypt (provide service protection) services with different service protection systems without transmitting multiple differently-encrypted copies of the services [11.10]. The Standard describes an architecture that is applicable to terrestrial broadcast systems delivered upon an IP delivery framework. The Standard may be applied to the broadcast of ATSC Mobile DTV signals and services and other IP-delivered services, and allows broadcasters to field pay services using alternate service protection systems.

11.2.3 CAS for DVB

Main parameters of CAS for DVB-T and -T2 are defined in Recommendation ITU-R BT.1852 [11.2]. In this recommendation, the system is referred to as “IEC 62455 with DVB systems”. It uses DVB Common Scrambling Algorithm (DVB-CSA) or AES-128 (mandatory for devices); also DES, 3DES and MULTI2 are possible (optional for devices). IEC 62455 specifies a standardized system for controlling access to broadcast services based on MPEG-2 transport stream for DVB systems. The IEC 62455 also specifies how the same system can be used for controlling the access to broadcast services based on Internet Protocol (IP). Thus, the specification is widely applicable to different broadcast systems, including systems where the protection cannot be accomplished on MPEG-2 transport stream packets (e.g. IP-based services delivered on non-MPEG-2 based networks).

CAS for DVB can be implemented as SimulCrypt and MultiCrypt.

DVB SimulCrypt system enables the usage of multiple receivers using different CA systems, by transmitting authorization data for each CA system simultaneously. No problems were noted so far on the possible constraints which the DVB SimulCrypt architecture might impose on the use of a shared scrambling and descrambling method [11.16], [11.17], [11.18].

DVB MultiCrypt system enables the usage of multiple CA systems by a single receiver with the utilization of common interface. Processing principles and basic parameters of the common interface for DVB systems as well as guidelines for implementation are provided in EN 50221 [11.11] and R206-001 [11.12], correspondingly. As a first extension, Common Interface v.2 was standardized [11.12]. This allows to implement additional functions such as support of status/ query functions, power and event management, application man machine interface, copy protection, software download and CA pipeline resources. Subsequently, the common interface specification was updated to version 3 [11.14].

Currently, the Common Interface specifications were extended by the CI PlusTM specification [11.15], which provides common methods (i.e. methods that are independent of the up-stream CA system) for mutual authentication of the Common Interface Conditional Access Module (CICAM) and Host, and link encryption over the return interface from the CICAM to the Host.

The following is a list of the features specified as extensions to CI PlusTM V1.3:

- Multi-stream handling.
- IP-delivered content.
- CI PlusTM browser extensions.
- CICAM application launching.

⁴¹ It should be noted that at the time of publication of this Handbook, ATSC is developing a new series of standards, ATSC 3.0, for digital television. Current information concerning these standards, both final and candidate, can be found on the ATSC website, www.atsc.org.

- URI (usage rules information) extensions.
- Watermarking and transcoding capability.

11.3 Content Protection and Copy Management

In addition to access control for television and other content in a broadcast environment, a further important technical task is the management of different aspects of content consumption by the end-users. In particular, this relates to content copy management for the purpose of Digital Rights Management (DRM).

In order to solve the above mentioned technical tasks, special information is transmitted containing data for content consumption control in a digital broadcast stream. This issue is highlighted in Report ITU-R BT.2070-1 [11.5]. This Report describes “state of the art” techniques of digital content protection for broadcast television and related services. Information provided in this Report relates to the description of commercial threats to broadcasters and content providers resulting from advances in technology, possible challenges for legitimate use of broadcast content, definition of architectural model and concepts for content protection in broadcast environments, giving, as an example, a solution for content protection implementation in Korea.

DRM systems vary, but they are all based on the concept of encrypting some or all of the content using device-specific or user-specific keys, and allowing access to those keys only to compliant implementations that will obey to the rights granted.

For example, the Content Protection System (CPS) in ISDB environment is addressed by ARIB STD-B25 Part 3. Part 3 of this standard specifies an access control system for use in digital broadcasting, a reception control system, notably a content protection system for free programme reception and defines scrambling, associated information specifications as well as related reception specifications [11.6].

CPS for DVB environment is referred to as DVB-CPCM [11.18]. DVB-CPCM is a system for Content Protection and Copy Management of commercial digital content delivered to consumer products. CPCM manages content usage from acquisition into the CPCM system until final consumption, or export from the CPCM system, in accordance with the particular usage rules of that content. Possible sources for commercial digital content include broadcast (e.g. cable, satellite, and terrestrial), internet-based services, packaged media, and mobile services, amongst others. CPCM is intended for use in protecting all types of commercial content-audio, video and associated applications and data. CPCM provides specifications to facilitate interoperability of such content by networked consumer devices for both home networking and remote access⁴².

Content Protection and Content Management for the ATSC environment is addressed in Standard A/98, “System Renewability Message Transport” [11.19]. This Standard defines the method for transport of System Renewability Messages. A System Renewability Message (SRM) is a message issued by the administrator of a Content Protection System (CPS) that, when sent to devices that use that CPS, can revoke permission of certain devices or groups of devices to obtain content protected by that CPS. Different CPSs will each have their own SRMs to maintain the integrity of their systems; e.g. in the event that device keys are stolen and cloned. In addition, the ATSC Standard A/65, “Program and System Information Protocol for Terrestrial Broadcast and Cable” [11.20], includes an “access controlled flag” to indicate that events associated with the broadcast channel may be access controlled.

Bibliography to Chapter 11

- [11.1] Question **ITU-R** 49-1/6, *Conditional-access broadcasting systems*
- [11.2] Recommendation **ITU-R** BT.1852, *Conditional-access systems for digital broadcasting*
- [11.3] Report **ITU-R** BT.1079-1, *General characteristics of a conditional access broadcasting system*
- [11.4] Report **ITU-R** BT.2052, *Protection of end-users’ privacy in interactive broadcasting systems*
- [11.5] Report **ITU-R** BT.2070-1, *Broadcasting of content protection signalling for television*

⁴² DVB-CPCM fact sheet: https://www.dvb.org/resources/public/factsheets/DVB-CPCM_Factsheet.pdf.

- [11.6] **ARIB** STD-B25 – *Conditional access system specifications for digital broadcasting*
- [11.7] **ARIB** STD-B61 – *Conditional access systems (second generation) and CAS program download system specifications for digital broadcasting*
- [11.8] **ATSC** Standard A/70 Part 1:2010 – *Conditional Access System for Terrestrial Broadcast*
- [11.9] **ATSC** Standard A/70 Part 2: 2011 – *Conditional Access System for Terrestrial Broadcast Service Protection using Simulcrypt for Internet Protocol-Delivered Services*
- [11.10] **DVB** EN 50221 – *Common Interface Specification for Conditional Access and other Digital Video Broadcasting Decoder Applications*
- [11.11] **CENELEC** R206-001 – *Guidelines for Implementation and Use of the Common Interface for DVB Decoder Applications*
- [11.12] **ETSI** TS 101 699 – *Digital Video Broadcasting (DVB); Extensions to the Common Interface Specification*
- [11.13] **ETSI** TS 100 289 – *Digital Video Broadcasting (DVB); Support for use of the DVB Scrambling Algorithm version 3 within digital broadcasting systems*
- [11.14] **ETSI** TS 103 205 – *Digital Video Broadcasting (DVB); Extensions to the CI Plus™ Specification*
- [11.15] **ETSI** TS 101 197 – *Digital Video Broadcasting (DVB); DVB SimulCrypt; Head-end architecture and synchronization*
- [11.16] **ETSI** TS 103 197 – *Digital Video Broadcasting (DVB); Head-end implementation of DVB SimulCrypt*
- [11.17] **ETSI** TR 102 035 – *Digital Video Broadcasting (DVB); Implementation Guidelines of the DVB Simulcrypt Standard*
- [11.18] **ETSI** TS 102 825 (Parts 1-14) – *Digital Video Broadcasting (DVB); Content Protection and Copy Management (DVB-CPCM)*
- [11.19] **ATSC** Standard A/98: 2007 – *System Renewability Message Transport*
- [11.20] **ATSC** Standard A/65: 2013 – *Program and System Information Protocol for Terrestrial Broadcast and Cable*

CHAPTER 12

Quality of the baseband signal

12.1 Introduction

It is recommended to use the information in Chapter 3 (Requirements for DTTB networks) to select a video and audio format as well as the average bit rate.

If further investigations are necessary as to how much the quality changes when not using the recommended values this section may serve as guidance.

Audio/video quality estimation in television systems is most frequently related to assessing the impact of potential impairment sources such as:

- The audio/video compression systems: Here the video quality estimation is related to the efficiency of the video compression algorithms in terms of trade-off between bit-rate and subjective/ objective quality.
- The transmission channel: In this case, we estimate the accuracy of the video recovered after passing through the end-to-end broadcast chain. However, in digital broadcasting the latter leads to either no influence on picture quality, or complete picture failure with a very small transition between them.

The quality level of an audio/video source can be quantified in two variants:

- Objectively (objective estimation) using mathematical metrics which compute a quality rating based on the pixels values of the video output (or the output audio signal).
- Subjectively (subjective estimation) where the assessment is made by a selection of human viewers/listeners according to a predefined methodology.

Objective quality metrics are easier and faster quality assessment tools. They are intended for use in a broad set of applications producing the same results with a given set of video sequences. The choice of video sequences to use and the interpretation of the resulting objective measurements should be adapted to the targeted application. Objective metrics can be used to reliably assess compression systems of the same family (for example block based codecs MPEG-4, MPEG-2 etc.) as they may provide similar visual artefacts. Section 12.2 provides an outline of existing objective metrics.

Subjective quality assessment methods are designated procedures to determine the average opinion of human viewers to a specific set of video sequences for a given application. They are therefore more complex to set up but more representative of viewers' responses to the level of quality. Results are valuable in basic system design and benchmark evaluations. Subjective quality assessments for a different application with different test conditions will still provide meaningful results; however, opinion scores for the same set of video sequences have different values [12.1]. Section 12.3 provides an outline of existing subjective metrics.

Objective measurements and subjective quality assessment are complementary rather than interchangeable. Subjective assessments are necessary to determine the required bitrates to sustain a certain quality level, selecting the bitrates for transmission etc. Objective measurements are required for equipment specifications and day-to-day system performance measurement and monitoring.

The most common types of quality control processes are:

- Manual QC (“Golden eyes/ears” monitor the programme).
- Automated QC (To check signal levels and standards).
- File Structure Compliance (To check against file standards, e.g. AS11 DPP).
- File Structure Analysis (Deep analysis where something is wrong with the file structure).

In the complex, integrated IP production and multiplatform distribution scenario, at risk of upset from trivial, incremental firmware and codec updates, it might be that regular “Golden eyes/ears” objective assessments of the entire chain might be the most pragmatic.

The EBU has a Strategic Programme on Quality Control (QC) that addresses audio-visual quality assessment⁴³.

12.2 Objective quality estimation for compression systems in digital television

Objective methods are based on testing signal parameters, using measuring equipment. Objective test results do not give full information about viewers' impressions concerning the observed programme. Especially in digital television, the exact correlations between picture disturbance and viewers' visual impressions may be missed [12.1].

Normative documents [12.2-12.13] describe the use of technical quality parameters for MPEG video and audio streams in the objective quality estimation for digital terrestrial.

12.2.1 Objective measurements for video compression quality estimation

These are referred to as objective perceptual measurements. They are the measurement of the performance of a programme chain by the use of programme-like pictures and objective (instrumental) measurement methods to obtain an indication that approximates the rating that would be obtained from a subjective assessment test. There are three basic methods to perform objective measurements:

- Full Reference (FR): a method applicable when the full reference video signal is available – double-ended method.
- Reduced Reference (RR): a method applicable when only the reduced video reference information is available – double-ended method.
- No Reference (NR): a method applicable when no reference video signal or information is available – single-ended method.

On the basis of VQEG⁴⁴ works, ITU-R Recommendations were prepared for objective perceptual video quality measurement technique for broadcasting applications in presence of full reference signal: [12.3] for SDTV, [12.4] for reduced definition. For objective perceptual video quality measurement technique for broadcasting applications with reduced bandwidth, see [12.5] for reduced definition and [12.6] for SDTV.

12.2.2 Objective measurements for video transmission quality estimation

These include:

- accuracy of programme stream synchronization (jitter and errors in the synchronization signal);
- level of structural distortions;
- temporal error metrics for video sequence (VFLR⁴⁵, VFDR⁴⁶, TER⁴⁷).

Metrics that can be used to determine the level of structural distortions are the following:

- Pixel Error Ratio (PxER);
- MPEG Block Error Ratio (BLER);
- MPEG Macroblock Error Ratio (MBLER);
- MPEG Slice Error Ratio (SLER).

⁴³ For more information see <https://tech.ebu.ch/groups/btf>.

⁴⁴ VQEG Video Quality Experts Group.

⁴⁵ VFLR: Video Frame Loss Ratio.

⁴⁶ VFDR: Video Frame Decoding Ratio.

⁴⁷ TER: Timing Error Ratio.

For the estimation of influence of distortions that arise in the broadcasting channel at the level of video sequences, the following metrics of technical quality can be used:

- Video Frame Loss Ratio (VFLR);
- Video Frame Decoding Ratio (VFDR);
- Timing Error Ratio (TER);
- Video Peak-Signal-to-Noise-Ratio (PSNR);
- Video Quality Metric (VQM);
- Moving Pictures Quality Metric (MPQM);
- Structural Similarity Index (SSIM);
- Noise Quality Measure (NQM).

12.2.3 Objective measurements for audio quality estimation

For the objective evaluation of audio quality, the following should be considered:

- Loudness;
- Maximum true peak;
- Loudness range;
- Frequency response;
- Signal-to-noise ratio;
- Mono-compatibility (phase difference between channels) / correlation.

The following parameters should be considered for the transmission channel of the audio content:

- Nominal bandwidth (which bandwidth is allowed by the codec);
- Noise level;
- Data rate;
- Jitter;
- Bit-error rate;
- Group-delay variation;
- Amplitude response;
- Non-linear distortion (THD);
- Intermodulation distortion.

For audio of digital TV systems, objective methods for quality estimation of perceived quality of compressed audio are provided in Recommendation ITU-R BS.1387 [12.14].

[12.14] is a very rigorous treatise on the subject of objective measurement of bitrate-reduced audio, and it remains relevant. It does point out, nevertheless, that the perceptual quality line up procedure takes place prior to taking a piece of equipment or a circuit into service, with a view of checking its functionality and quality (for the end user). In broadcasting terms this means that every element that contributes to the A/V signal (programme audio, video, subtitles, clear narration, audio description, signing video/avatar, etc.) is produced in an appropriate quality for consumption. The actual (objective) quality of experience obtained by the end user may well exceed the sum of the parts when personalised choices are factored in to the equation.

A danger of the integrated approach to content production and multiplatform dissemination of A/V content (especially over IP infrastructures) is that of changing operating software (firmware) and codec parameters. A trivial change in the firmware of one element in the entire A/V chain might have enormous impact on the quality of experience of the end user (visible lip-sync errors, for instance); therefore, the concept of the perceptual quality line-up introduced in [12.14] is rarely used in practice.

12.2.4 Remarks on future developments

Audio technology in TV is developing beyond the traditional stereophonic and 5.1-channel configurations towards immersive multi-channel (up to 22.2 speaker channels) replay that includes the representation of height, as well as to scene-based and object-based audio.

This latter will especially facilitate broadcasters' audio services such as personalisation and accessibility for the perceptually-impaired user. The advantage for the broadcasters is expected to be that the audio production is simplified to only a single process since the object-based audio elements are rendered in the receiver according to the users' preferences and actual loudspeaker configurations.

It must also not be forgotten that the current trends for the consumption of TV extend to non-linear and mobile/portable use, where in particular, audio is consumed through headphones. Advanced services will need something like binaural technology to transfer into these platforms.

For the purpose of evaluation, it is crucial to have a standardized renderer which is capable of rendering all technologies and content types mentioned in the Advanced Sound Systems Recommendations ITU-R BS.2051 [12.15], ITU-R BS.2076 [12.16] and Report ITU-R BS.2388 [12.17]. This work is currently in progress within ITU-R Working Party 6C. The renderer should be used for quality evaluations in general as well as for loudness measurement and production.

Furthermore, it would be important to develop and agree on methods for the objective and subjective evaluation of Advanced Sound Systems.

For more information on transmission quality parameters, see Chapter 7.

12.3 Subjective quality estimation for compression systems in digital television

Subjective evaluations are based on observation of the estimated programme by groups of observers, who give adequate opinions about the quality of the programme and treating these opinions statistically [12.1].

The basic methods of subjective estimation, used for testing new and/or existent codecs during video compression in the television systems are defined in Recommendation ITU-R BT.500-13 [12.8]. Two basic methods are described here:

- The DSCQS (double stimulus continuous quality-scale), using a continuous quality scale. It can in particular provide accurate results for very small differences in quality, and where impairments have either a positive or negative effect on quality. This method is used to measure the quality of compression system implementation relative to a reference.
- DSIS evaluation method (double stimulus impairment scale), based on agreed impairment scales for psycho-physical testing of television. The scales are used in a controlled and defined way; the results of tests obtained are valid, reliable, and consistent between tests. This method is used to measure the robustness of systems (i.e. failure characteristics).

The following are alternative methods to DSIS and DSCQS:

- Single-stimulus (SS) methods: a single image or sequence is presented – an index on the entire presentation. Contains: numerical categorical judgment methods, non-categorical judgment methods and performance methods.
- Stimulus comparison methods: two images or sequences are presented – an index of the relation between the two presentations. Contains: adjectival categorical judgment methods, non-categorical judgment methods and performance methods.
- Single stimulus continuous quality evaluation (SSCQE): digitally coded video (scene-dependent and time varying) is measured continuously, with subjects viewing the material once, without the source reference.
- Simultaneous double stimulus for continuous evaluation method (SDSCQE), in which the reference condition is introduced to SSCQE.

[12.8] describes the general methods of subjective assessment, the details concerning the application to subjective assessment of measured systems are provided in the following connected recommendations:

- Recommendation ITU-R BT.1128 on subjective assessment of conventional television systems.
- Recommendation ITU-R BT.1129 on subjective assessment of standard definition digital television systems (SDTV).
- Recommendation ITU-R BT.710 on subjective assessment methods for image quality in high-definition television.
- Recommendation ITU-R BT.812 on subjective assessment of the quality of alphanumeric and graphic pictures in Teletext and similar services.
- Recommendation ITU-R BT.1210 on test material to be used in the subjective assessment of picture quality.
- Recommendation ITU-R BT.2021 on subjective methods for the assessment of stereoscopic 3DTV systems.
- Recommendation ITU-R BT.2022 General viewing conditions for subjective assessment of quality of SDTV and HDTV television pictures on flat panel displays.
- Recommendation ITU-R BT.2035 on reference viewing environment for evaluation of HDTV programme material or completed programmes.
- Recommendation ITU-R BT 1788 on subjective assessment methodology for Video Quality.

For TV systems, the assessment of Audio can be done using the following subjective methods:

- Recommendation ITU-R BS.1116: Methods for the subjective assessment of small impairments in audio systems.
- Recommendation ITU-R BS.1284: General methods for the subjective assessment of audio quality.
- Recommendation ITU-R BS.1285: Pre-selection methods for the subjective assessment of small impairments in audio systems.
- Recommendation ITU-R BS.1286: Methods for the subjective assessment of audio systems with accompanying picture.
- Recommendation ITU-R BS.1534: Method for the subjective assessment of intermediate quality levels of coding systems.
- Recommendation ITU-R BS.1679: Subjective assessment of the quality of audio in large screen digital imagery applications intended for presentation in a theatrical environment.

Bibliography to Chapter 12

- [12.1] Karwowska-Lamparska, Alina World progress in video and audio quality evaluation and control in broadcasting systems *Technology of digital broadcasting: strategy of introduction in Ukraine (DBT-2011)*. Proceedings of international scientific-technical conference, Odessa, ONAT n.a. A.S. Popov, 20–22 Junes 2011.
- [12.2] Recommendation ITU-R BT.1683, *Objective perceptual video quality measurement techniques for standard definition digital broadcast television in the presence of a full reference*
- [12.3] Recommendation ITU-R BT.1721, *Objective measurement of perceptual image quality of large screen digital imagery applications for theatrical presentation*
- [12.4] Recommendation ITU-R BT.1866, *Objective perceptual video quality measurement techniques for broadcasting applications using low definition television in the presence of a full reference signal*
- [12.5] Recommendation ITU-R BT.1867, *Objective perceptual visual quality measurement techniques for broadcasting applications using low definition television in the presence of a reduced bandwidth reference*

- [12.6] Recommendation ITU-R BT.1885, *Objective perceptual video quality measurement techniques for standard definition digital broadcast television in the presence of a reduced bandwidth reference*
- [12.7] Recommendation ITU-R BT.1907, *Objective perceptual video quality measurement techniques for broadcasting applications using HDTV in the presence of a full reference signal*
- [12.8] Recommendation ITU-R BT.500-13, *Methodology for the subjective assessment of the quality of television pictures*
- [12.9] Recommendation ITU-R BT.813, *Methods for objective picture quality assessment in relation to impairments from digital coding of television signals*
- [12.10] Recommendation ITU-R BT.1676, *Methodological framework for specifying accuracy and cross-calibration of video quality metrics*
- [12.11] Recommendation ITU-R BT.1790, *Requirements for monitoring of broadcasting chains during operation.*
- [12.12] Recommendation ITU-R BT.1908, *Objective video quality measurement techniques for broadcasting applications using HDTV in the presence of a reduced reference signal*
- [12.13] Report ITU-R BT.2020, *Objective quality assessment technology in a digital environment*
- [12.14] Recommendation ITU-R BS.1387, *Method for objective measurements of perceived audio quality*
- [12.15] Recommendation ITU-R BS.2051, *Advanced sound system for programme production*
- [12.16] Recommendation ITU-R BS.2076, *Audio Definition Model*
- [12.17] Report ITU-R BS.2388, *Usage guidelines for the audio definition model and multichannel audio files*

CHAPTER 13

Digital TV receivers

13.1 General aspects for DTTB receivers

Currently there are many possible digital television receiver implementations but the requirement of compatibility with a specific broadcasting system standard (e.g. ATSC, ISDB, DTMB, DVB, etc.) is mandatory. This requirement assumes the usage of the same algorithms as those corresponding to the baseline standard as described in Chapter 9 to ensure digital television service signal reception (in a case of compliance with conditions of successful reception). The rest of the receiver functionality may vary between manufacturers and is determined by receiver cost and additional customer requirements. Portions of the receiver which are not standardized (e.g. channel estimation and compensation block) by the baseline system standard, may be implemented in various ways.

During the transition to digital broadcasting, the problem of providing the population with suitable receivers arises. In this case, it may be necessary to inform people about the advantages of the transition and to define a minimum set of equipment requirements for digital television signal reception. An important component of a successful transition is broadcast quality – both technical and non-technical. Quality is often the determining factor for users. Additionally, the transition cost is important: prices too high are likely to reduce the attractiveness for users so trade-offs between quality and functionality are important.

13.2 Requirements for DTTB receivers

In general, the DTTB receiver is defined by a set of requirements that includes the following components:

- RF tuner;
- demodulator;
- audio decoder;
- video decoder;
- interfaces;
- hardware;
- software;
- other components.

The requirements for digital television broadcasting receivers need to consider the relationship between the specific requirements and the existing and future national normative base of technical standards and norms. This consideration will allow separate blocks of the receiving equipment to be checked for compatibility with defined national and international standards.

A minimum set of the receiver requirements may be defined for several signal profiles – for example, for both standard and high definition digital television – in order to supply different population profiles with differentiated digital broadcasting services.

A digital television broadcasting receiver may contain one or more RF modules that provide reception of program distribution from satellite, cable, or terrestrial transmission. During a transition from one generation of television to another (such as analogue to digital, or digital to digital, e.g. from DVB-T to DVB-T2) it is common practice for receivers to provide reception from more than one generation.

Transport stream scrambling is a procedure for management of a pay-per-view access to the digital television broadcasting service. The approach may be also used for free-to-air services but restrict access for unauthorized users to the digital broadcast network and to control copyrights in a case of its distribution and recording by PVR or VCR devices. The scrambling method (if applicable) is defined by each particular broadcasting

organization and implemented in general case by a Conditional Access Module (CAM). Conditional access is dealt with in more detail in Chapter 11.

An optional requirement may be worldwide broadcast roaming. Broadcast roaming may be useful for those users travelling around the world. The implementation of broadcast roaming may require the additional functions of:

- portability;
- compatibility with various broadcasting systems; and
- support for programme information.

More information on the requirements for broadcast roaming is provided in Recommendation ITU-R BT.2072 [13.1].

Currently there are various digital broadcasting standards used throughout the world. Recommendations ITU-R BT.1368 [13.2] and ITU-R BT.2033 [13.3] describe the planning criteria, including protection ratios, for first and second generation digital terrestrial television systems, respectively. In addition, Recommendation ITU-R BT.2036 [13.4] provides detailed receiver characteristics important for successful television reception. Report ITU-R BT.2215 [13.5] provides the results of laboratory performance measurements made on various digital television receivers.

The following sections describe the available standards for digital television receivers in the VHF and UHF bands. Section 13.2.5 gives a summary of general requirements.

13.2.1 ATSC receivers

For the ATSC system the receiver requirements are defined by⁴⁸:

- Recommended Practice A/74:2010 “Receiver Performance Guidelines” [13.6]. The document addresses the front-end portion of a fixed terrestrial digital terrestrial television broadcast receiver. The recommended performance guidelines enumerated in this document are intended to assure that reliable reception will be achieved. Guidelines for interference rejection are based on the FCC planning factors that were used to analyse coverage and interference for the initial DTV channel allotments. Guidelines for sensitivity and multipath handling reflect field experience accumulated by testing undertaken by ATTC, MSTV, NAB, and receiver manufacturers.
- Recommended Practice A/174:2010 “Mobile Receiver Performance Guidelines” [13.7]. The document addresses the signal conditions that may be encountered with assessment of the potential impact upon the front-end portion of a receiver of A/153-based mobile digital television broadcasts (ATSC-M/H). This document provides recommended performance guidelines that are intended to maximize reception. In general, the recommendations in this document build on those contained in A/74 (which applies to fixed terrestrial receivers), with the addition of new guidelines pertinent to mobile reception. Areas where the recommendations are new or different include: dynamic multi-path, antenna configurations in mobile receivers, the effects of more limited power supplies, possible proximity to interfering signals, and presence of unlicensed devices radiating in the TV bands.
- ATSC Standard A/53, Parts 1 through 6 “ATSC Digital Television Standard” [13.8]. The Digital Television Standard describes the system characteristics of the advanced television (ATV) system. The document and its normative Parts provide detailed specification of the parameters of the system including the video encoder input scanning formats and the preprocessing and compression parameters of the video encoder, the audio encoder input signal format and the pre-processing and compression parameters of the audio encoder, the service multiplex and transport layer characteristics and normative specifications, and the VSB RF/Transmission subsystem.

⁴⁸ It should be noted at this time ATSC is developing a new series of standards, ATSC 3.0, for digital television. Current information concerning these standards, both final and candidate, can be found on the ATSC website, www.atsc.org.

13.2.2 ISDB-T / SBTVD receivers

For the ISDB-T/ SBTVD system the receiver requirements are defined by:

- ARIB STD-B21:2007 “Receiver for digital broadcasting” [13.9]. The ARIB standard applies to: receivers for digital broadcasting among the various types of standard television broadcasting, high-definition television broadcasting, ultra-high-frequency wave broadcasting, and data broadcasting carried out by broadcasting satellite stations in the frequency band of 11.7-12.2 GHz (BS digital broadcasting); receivers for standard television broadcasting, high-definition television broadcasting, ultra-high-frequency wave broadcasting, and data broadcasting with a bandwidth of 34.5 MHz carried out by broadcasting satellite stations in the frequency band of 12.2-12.75 GHz (broadband CS digital broadcasting); and receivers for digital broadcasting and high-definition television broadcasting among the various types of standard television broadcasting carried out by broadcasting stations.
- Harmonized documents ARIB STD-B21 and ABNT NBR 15604 [13.10]. These documents characterize the receiver for digital terrestrial television broadcasting as standardized in Brazil (SBTVD – Sistema Brasileiro de Televisão Digital) and Japan (ISDB-T) as of June 2009. Its purpose is to serve as a reference for characterizing the specificities of Brazilian and Japanese digital terrestrial television standards within the scope of the Brazil-Japan Digital Television Joint Working Group.

13.2.3 DVB-T / DVB-T2

For the DVB-T/ DVB-T2 system the receiver requirements are defined by:

- ETSI EN 303 340 (2016) [13.11] Digital Terrestrial TV Broadcast Receivers; Harmonized Standard covering the essential requirements of Article 3.2 of the Directive 2014/53/EU. The document applies to digital terrestrial television broadcast receivers fitted with an external antenna input (tuner port) or RF test connector capable of receiving DVB-T and/or DVB-T2 signals. It contains the requirements for Digital Terrestrial Television broadcast receivers to meet the essential requirements of Article 3.2 of the Radio Equipment Directive (i.e. Directive 2014/53/EU [13.29]) that radio equipment both effectively uses and supports the efficient use of radio spectrum in order to avoid harmful interference.⁴⁹ It also considers interference from LTE transmissions in the 700 MHz and 800 MHz bands. The requirements of the installation system (antenna, feeder cable, amplifiers, etc.) are not addressed.
- ETSI TR 103 288 (2016) [13.12] Electromagnetic compatibility and Radio spectrum Matters (ERM); Report of the CENELEC/ETSI Joint Working Group in response to the EC letter ENTRP/F5/DP/MM/entr.f5.(2013)43164 to the ESOs. This document:
 - investigates and documents anticipated and/or planned changes in frequency use in the band 470-862 MHz including the relevant characteristics of the expected radio technologies to be deployed in these and neighbouring bands, in particular the 863-870 MHz band used by Short-Range Devices (SRD);
 - develops a description of the emerging electromagnetic environment in the above bands and evaluate how these changes will affect the co-existence services, systems and equipment;
 - makes recommendations to the CENELEC and ETSI committees to revise affected Harmonized Standards and other European Standards as necessary to improve to co-existence of relevant services and equipment.
- IEC 62216 (2009) Digital terrestrial television receivers for the DVB-T system [13.13]. This specifies both Standard Definition and High Definition receivers for the DVB-T system. Subtitling and teletext are considered to be components of TV services. It addresses terrestrial delivery of digital transmissions and deployment in countries that use European Latin script based languages. Two types of systems are considered:
 - standard systems where services are all SD; and

⁴⁹ Ref. <http://www.etsi.org/technologies-clusters/technologies/regulation-legislation/red>.

- use well-established codecs.

Standard receivers which can decode standard services are suitable for these systems; advanced systems where some services may use advanced codecs, for example to provide HD video. Advanced receivers which can decode advanced services are suitable for these systems⁵⁰.

- ETSI TS 101 154 (2009) Digital Video Broadcasting (DVB) [13.14]. The document is a specification for the use of Video and Audio Coding in Broadcasting Applications based on the MPEG-2 Transport Stream. The guidelines presented in the document for the Integrated Receiver-Decoder (IRD) are intended to represent a minimum functionality that all IRDs of a particular class are required to either meet or exceed. It is necessary to specify the minimum IRD functionality for basic parameters to ensure use of certain features.
- EBU Tech 3307 Service Requirements for Free-to-Air High Definition Television Receivers [13.15]. This document outlines the general requirements, as perceived by EBU members, of free-to-air broadcasters for the reception of HDTV services, whether by DVB-T, DVB-S or S2, or by other means. It is intended as a discussion document for manufacturers, broadcasters, operators, and national HDTV platforms.
- EBU Tech 3333 EBU HDTV Receiver Requirements [13.16]. This document represents the minimum HDTV receiver requirements of EBU members (the broadcasting organizations) and has been discussed in detail with DIGITALEUROPE (EICTA) representatives. Media industries developing stand-alone receiver (set-top boxes – STB or integrated receiver decoders – IRDs) or receivers with integrated digital televisions (iDTVs) are encouraged to comply with this set of requirements in order to allow interoperability between EBU Members' broadcasts and the receiver device.
- ETSI TS 102 201 (1999) Digital Video Broadcasting (DVB); Interfaces for DVB Integrated Receiver Decoder (DVB-IRD) [13.17]. This document is an application standard, identifying recommended interfaces for connections of Digital Video Broadcast Integrated Receiver Decoder (DVB-IRD) equipment.

13.2.4 DTMB

For the DTMB system the receiver requirements are defined by:

- GB/T 26686-2011 – General specification for digital terrestrial television receiver [13.18]. This standard describes the functional and performance requirements, inspection rules, mark, package, transport, storage of terrestrial DTV receivers which support the DTMB standard GB20600-2006.
- GB/T 26685-2011 – Methods of measurement for digital terrestrial television receiver [13.19]. This standard is applied to the terrestrial DTV receiver and describes items, condition and methods for performance measurement of terrestrial DTV receiver that support the DTMB standard GB20600-2006.
- GB20600-2006 – Framing Structure, Channel Coding and Modulation for Digital Television Terrestrial Broadcasting System (DTMB) [13.20]. This standard describes the framing structure, channel coding and modulation for digital television terrestrial broadcasting in UHF (Ultra-High Frequency) and VHF (Very-High Frequency) band with 8 MHz bandwidth for each RF (Radio Frequency) channel. The DTMB standard can be applied to digital television terrestrial broadcasting systems carrying multiple SDTV programs or HDTV programs for both mobile and stationary reception.

⁵⁰ Similar specifications exist on the national level: e.g. DTG D-Book for UK, NorDig for Nordic countries.

13.2.5 General Requirements

Generalized requirements for a DTTB receiver are given in Table 13.1. This table defines possible values for particular parameters provided by the corresponding standards, but not all receivers must comply with all these. The parameters specific for a particular DTTB system and the RF parameters each transmission system are not given. Detail information on a particular DTTB system is contained in the relevant documents listed in the references for this section as well as the relevant sections of Chapter 9 of this Handbook.

TABLE 13.1

Summary of possible requirements to digital terrestrial television broadcasting receivers

Parameter	Value	Note
Aspect Ratio	4:3, 16:9	Picture can be rescaled between aspect ratios supported by display
Video resolution	HDTV, SDTV, 4K and 8K UHD TV	
Frame rate/ scanning	25P, 50I, 50P, 30P, 59.94I, 60I, 60P, 120P	
Video service	Conventional TV, 3DTV	
Video compression	MPEG-2, MPEG-4 AVC/ H.264, SVC, HEVC/ H.265, AVS	
Colorimetry	ITU-R Rec. BT.601, Rec. BT.709, Rec. BT.2020	
Additional video functionalities	Overscan, scaling between UHD, HD and SD, Active Format Descriptor (AFD), Wide Screen Signaling (WSS), Personal Video Recorder (PVR), Time-shift, HDR, HFR	Provided as examples
Audio mode	Mono, stereo, multi-channel	
Audio compression	MPEG-1, MPEG-2, MPEG-4, HEVC, AC3, DTS	
Middleware	MHP, GEM, Ginga, MHEG-5	(or any other middleware implementation)
Service functionalities	EPG, Subtitles and Teletext (in “normal” and “hard of hearing” modes), Clean audio, Closed Captions, Software update, LAN-Access (Fast Ethernet, Wireless LAN or Powerline), Hybrid Broadcast/ Broadband (e.g. HbbTV)	Provided as examples
Interfaces	Common Interface (CI) and CI+, Ethernet, S/PDIF (optical or electrical), HDMI, YPbPr, RF loop-through, SCART	Provided as examples

13.3 Middleware for DTV receivers

Middleware is a layer of software that lies between the application code and the run-time infrastructure (hardware platform and operating system). Middleware for digital television applications generally consists of language engines and libraries of functions. The existence of the middleware is a pre-requisite for the easy and fast development of TV applications.

The DTTB receiver middleware is a basic element for user interaction with the receiver hardware. The requirements of middleware include flexibility, wide functionality and program interface simplicity. Quite often the situation occurs when it is impossible to meet one requirement without complicating another requirement. In most cases, therefore, certain middleware implementation is a trade-off. The ability to update receiver software is desirable during the introduction of new services, especially those updates that require the middleware to be supplemented with some additional functionality or when correcting errors that have appeared in the middleware design process. Updates can be accomplished directly by the service provider from

an off-air channel or directly by users of a set-top box or device with an integrated receiver-decoder using official manufacturer sites.

First-generation middleware variants included MHP/GEM and MHEG-5 [13.21], [13.22]. These have generally been superseded by the systems described in Chapter 10, such as HbbTV, Hybridcast, HTML5, HTML5-based Smart TV Platform and Ginga. [13.26], [13.27], [13.23].

13.4 Integrated Broadcast-Broadband functionality

Integrated broadcast-broadband (IBB) technologies are related to the implementation of the interactive TV approach. Such technologies are based on convergent TV receivers that are able to handle not only the broadcast signal but also applications delivered via broadband telecommunication services. This gives the receiver the opportunity to drive user engagement and to maximize the end-user's satisfaction by offering a range of new services.

All main functions and requirements for IBB applications are defined in Recommendation ITU-R BT.2037 – General requirements for broadcast-oriented applications of integrated broadcast-broadband systems and their envisaged utilization [13.24] and Recommendation ITU-R BT.2053 – Technical requirements for integrated broadcast-broadband systems [13.25].

For enabling IBB services special receiver module blocks, interfaces and middleware are needed. The receiver modules include blocks for broadcasting signals (a satellite, cable and/or terrestrial integrated or external receiver is needed) and a block for broadband signal processing (in most cases based on IP protocol). These receivers will be equipped with both broadcast and broadband consumer interfaces.

Special software functions for conventional or related middleware functions are needed. Such elements will provide shared processing and related coordination between broadcast and broadband environments, related interactive applications for the user, and other useful functionality. According to the requirement on application functionality in [13.24], IBB systems should:

- ensure integrity of broadcasting content and services, free of unauthorized overlays;
- clearly identify the content source, as well as, free and paid services;
- ensure that the content and service they provide can be easily accessed by users, in an unaltered form;
- protect copyright;
- ensure the user is aware of what kind of data is collected, by whom and for what purposes, including but not limited to viewing, usage or search data and profile information and respecting the user's privacy; and
- avoid unintended behaviour from malicious activities such as viruses, malwares, etc.

Also IBB systems should be:

- capable of bringing new services to users leveraging the functionality from broadcast and Internet at the same time;
- able to support linear and non-linear services and content;
- capable of presenting emergency broadcast content properly;
- able to support the integration of second screen communication and its synchronization to the services presented on the main sound and image display;
- capable such that the content can be accessed in a barrier free manner for people with disabilities; and
- capable of providing mechanisms to offer targeted services and content.

So such functionality applies related requirements to middleware and software receiver elements. All these aspects must be taken into account during the implementation of the relevant receivers.

Bibliography to Chapter 13

- [13.1] Recommendation ITU-R BT.2072, *Main functionalities of consumer receivers for worldwide broadcasting roaming.*
- [13.2] Recommendation ITU-R BT.1368, *Planning criteria, including protection ratios, for digital terrestrial television services in the VHF/UHF bands.*
- [13.3] Recommendation ITU-R BT.2033, *Planning criteria, including protection ratios, for second generation of digital terrestrial television broadcasting systems in the VHF/UHF bands.*
- [13.4] Recommendation ITU-R BT.2036, *Characteristics of a reference receiving system for frequency planning of digital terrestrial television system.*
- [13.5] Report ITU-R BT.2215, *Measurements of protection ratios and overload thresholds for broadcast TV receivers.*
- [13.6] ATSC Recommended Practice A/74:2010 – *Receiver Performance Guidelines.*
- [13.7] ATSC Recommended Practice A/174:2010 – *Mobile Receiver Performance Guidelines.*
- [13.8] ATSC Standard A/53, Parts 1 through 6: ATSC – *Digital Television Standard.*
- [13.9] ARIB STD-B21:2007 – *Receiver for digital broadcasting.*
- [13.10] Harmonized documents ARIB STD-B21 and ABNT NBR 15604.
- [13.11] ETSI EN 303 340 (2016) – *Digital Terrestrial TV Broadcast Receivers; Harmonized Standard covering the essential requirements of article 3.2 of the Directive 2014/53/EU*
- [13.12] ETSI TR 103 288 (2016) – *Electromagnetic compatibility and Radio spectrum Matters (ERM); Report of the CENELEC/ETSI Joint Working Group in response to the EC letter ENTRP/F5/DP/MM/entr.f5.(2013)43164 to the ESOs.*
- [13.13] IEC 62216 – *Digital terrestrial television receivers for the DVB-T system*
- [13.14] ETSI TS 101 154:2009 – *Digital Video Broadcasting (DVB); Specification for the use of Video and Audio Coding in Broadcasting Applications based on the MPEG-2 Transport Stream.*
- [13.15] EBU Tech 3307 – *Service Requirements for Free-to-Air High Definition Television Receivers.*
- [13.16] EBU Tech 3333 EBU HDTV – *Receiver Requirements.*
- [13.17] ETSI TS 102 201 – *Digital Video Broadcasting (DVB); Interfaces for DVB Integrated Receiver Decoder (DVB-IRD).*
- [13.18] Chinese National Standard GB/T 26686-2011 – *General specification for digital terrestrial television receiver.*
- [13.19] Chinese National Standard GB/T 26685-2011 – *Methods of measurement for digital terrestrial television receiver.*
- [13.20] DTMB GB20600-2006 – *Framing Structure, Channel Coding and Modulation for Digital Television Terrestrial Broadcasting System (DTMB).*
- [13.21] MHP/GEM official web-site: www.mhp.org.
- [13.22] MHEG-5 official web-site: www.mheg.org.
- [13.23] Ginga official web-site <http://www.ginga.org.br>.
- [13.24] Recommendation ITU-R BT.2037, *General requirements for broadcast-oriented applications of integrated broadcast-broadband systems and their envisaged utilization.*
- [13.25] Recommendation ITU-R BT.2053, *Technical requirements for integrated broadcast-broadband systems.*
- [13.26] Recommendation ITU-R BT.2075-0, *Integrated broadcast-broadband system.*

- [13.27] Report ITU-R BT.2267-5, *Integrated broadcast-broadband systems*.
- [13.28] ETSI ES 202 184 MHEG-5 – *Broadcast Profile*.
- [13.29] European Union Directive 2014/53/EU of the European Parliament and of The Council, 16 April 2014 on the harmonisation of the laws of the Member States relating to the making available on the market of radio equipment and repealing Directive 1999/5/EC, ref. <http://eur-lex.europa.eu/eli/dir/2014/53/oj>.

CHAPTER 14

Accessibility aspects

14.1 ITU and the need for access services

There are more than one billion people on Earth suffering from physical or mental disabilities [14.1]. About 15% of the world's population suffer from more or less severe disabilities that hamper their access to telecommunication services. Around 16% of adult Europeans have health problems that make access to and use of broadcast programmes difficult or impossible.

Naturally, with age, an increasing number of people have hearing and/or viewing problems as well as reductions in mobility that can make the control of apparatuses difficult, e.g. operating the TV remote control. By the year 2020, 50% of the European population will be older than 50 years. Hardly any of our fellow citizens beyond the age of 80 has an adequate sense of hearing. International organisations have been acting for many years in order to make available additional access services and technical means that alleviate or enable, for people with disabilities, for the elderly but also for minorities, the access to TV services.

In many countries, television broadcasters are obliged (or oblige themselves) to offer specific access services for people with decreased ability, i.e. people with disabilities including the elderly, in order to enable (or at least improve) their access to the broadcasting services over air and online.

As an UN organ, ITU is naturally bound by the United Nations Convention on the Rights of Persons with Disabilities (UNCRPD).⁵¹ ITU itself issued a series of relevant Resolutions: Resolution 70 (Johannesburg, 2008) of the World Telecommunication Standardization Assembly, Resolution 58 (Hyderabad, 2010) of the World Telecommunication Development Conference and Resolution 175 of the ITU Plenipotentiary Conference (Guadalajara, 2010). The latter is entitled "Telecommunication/information and communication technology accessibility for persons with disabilities, including age-related disabilities", and instructs all three ITU Sectors "to take into account the needs of persons with disabilities in the work of the ITU".

ITU cooperates with other organizations in developing standards for people with disabilities, having special needs for the consumption/usage of electronic media. An example is the joint publication with G3ict "Making Television Accessible"⁵². A more general example is the so-called Pink Report "The ICT Opportunity for a Disability-Inclusive Development Framework" to the development of which ITU contributed as a member of the Broadband Commission.⁵³

In its most recent position paper, the New European Media Initiative NEM⁵⁴ has compiled an extensive list of societal and policy aspects for audio-visual media access services (with a specific view on Europe). [14.2]

⁵¹ United Nations, "UN Convention on the Rights of Persons with Disabilities", 2006, ref. <http://www.un.org/disabilities/>

⁵² Joint Report by ITU and G3ict, "Making Television Accessible", ITU Telecommunication Development Bureau, Nov. 2011, ITU Press Release, Geneva, 5 Dec. 2011, ref. http://www.itu.int/net/pressoffice/press_releases/2011/51.aspx and http://www.itu.int/ITU-D/sis/PwDs/Documents/Making_TV_Accessible-E-BAT.pdf
NOTE – This report was prepared by Peter Olaf Looms, Chairman ITU-T Focus Group on Audiovisual Media Accessibility (<https://www.itu.int/en/ITU-T/focusgroups/ava/Pages/default.aspx>).

⁵³ Ref. <https://www.itu.int/en/action/accessibility/Pages/hlmdd2013.aspx>

⁵⁴ NEM was, under the name Networked Electronic Media, established as one of the European Technology Platforms under the Seventh EC Framework Programme to foster the convergence between consumer electronics, broadcasting and telecoms. The initiative was renamed New European Media, expanding its scope to Connected, Converging and Interactive Media & Creative Industries (ref. <http://nem-initiative.org/>)

14.2 Access services relevant to TV broadcasting

The introduction of digital television has led, in comparison with analogue TV, to increased capabilities for providing access services, both in terms of data capacity as well as in terms of features such as personalized (consumer-adjustable) representation. Typical access services comprise:

- Subtitles for the hard of hearing (as well as for minorities).
- Audio-description for the visually impaired.
- Clean audio (improved dialogue intelligibility) for the elderly and for people with reduced hearing acuity).
- Sign-language interpretation for deaf people who rely on sign language.
- Additional sound-tracks for minorities.

In modern digital TV systems, all access services are considered to be available upon request only by interested end-users. People who would profit from access services should be able to select them (in an easy and user-friendly manner). For people who do not wish to make use of a specific access service, it should remain unnoticeable. In other words, access services should be closed and only visible/audible when selected.

With respect to sound and television broadcasting, the Working Parties of Study Group 6 (SG 6) have been active in establishing technical Reports and Recommendations that can help improving accessibility. In 2010, ITU-R SG 6 published Report ITU-R BT.2207 – Accessibility to broadcasting services for persons with disabilities, which was updated in 2011 and in 2012.⁵⁵ This Report deals specifically with disabilities that can hamper the consumption of audio-visual media:

- hearing disabilities;
- seeing disabilities;
- aging disabilities;
- cognitive disabilities;
- lack of controllability of the man-machine interface and ease of use of the receiver or terminal.

Consequently, the Report deals with subtitles/captions, sign-language and text-to-speech to cope with hearing disabilities, audio description for visually impaired people and special means for the elderly. A specific section deals with receiver user-friendliness. There has been a growing interest in “universal-design products” that anyone can use with ease. The Report is complemented by an Annex that addresses, in six sections, various technologies to improve the accessibility to broadcasting services, especially in Japan. Section 1 treats speech rate conversion for elderly people whilst section 2 describes real-time closed-captioning using speech recognition, and section 3 deals with a multimedia browsing system for visually impaired people. Section 4 of the Annex gives an example of machine translation to sign-language with CG (computer-graphical) animation whilst section 5 provides information on a device for evaluating broadcast background sound balance for elderly listeners (improvement of intelligibility by adjustment of the loudness of background sounds (noise or/and music) to an appropriate level). Finally, section 6 informs about research into a technology for an easy-to-read language broadcasting service and language conversion support to in the understanding of complex Japanese texts.

The type and the number of access services for DTTB need to be considered during the capacity planning process. It is suggested that administrations reserve sufficient bit-rate for future use of access services, especially for audio description and closed caption.

14.3 Receiver-processed versus broadcast-based access services

Most access services have to be prepared and provided by the broadcasters (subtitles, audio-description, video of human sign language interpreter). Others, such as clean audio or spoken subtitles can be realized by either an additional programme stream provided by the broadcaster or can be derived, in the receiver, by appropriate software. In research, algorithms are under development that would derive a computer-generated sign language

⁵⁵ All Reports of ITU-R SG6 can be downloaded via <https://www.itu.int/pub/R-REP-BT/en>

interpreter (a so-called avatar) from text, for example from subtitles or after speech-to-text conversion in the receiver. Tests have, however, shown, that most people who rely on sign-language as their mother tongue are not (yet) satisfied with the reproduction of sign language by avatars in television, especially the lack of facial expressions which is still problematic. An example of the current state-of-the-art can be found within the European R&D project HBB4ALL.⁵⁶

Motion or speech control of the TV device are extremely useful features for people with cognitive or motoric restrictions but can only be made possible by the receiver manufacturers. In general, for maximum benefit to those with special needs, broadcasters and consumer-device manufactures have to cooperate in the development of access services and features.

14.4 The use of subtitles/captions

Whilst additional sound or vision tracks are just further programme elementary streams, there are various modes for subtitles. Taking DVB as an example, there are two subtitling standards currently in use: EN 300 472 [14.8] (first published in 1994) specifies the transport of Teletext subtitles of the analogue ITU-R TV System B within the MPEG-2 Transport Stream.

The receivers render the text in accordance with their stored font. EN 300 743 [14.9] (published in 1997) specified a bitmap approach. Line by line, characters and graphics are sent in bitmap representation. No font needs to be stored in the receiver. In both cases, however, the teletext and the so-called DVB subtitles, there is no possibility for user-customization (e.g. individual setting of subtitle position, size, colour, font or transparency of the background box).

To address those concerns, EBU developed a TTML-based format: EBU Timed Text (EBU-TT) for broadcasting and EBU-TT-D for online delivery, which make use of XML to render subtitles in line with the user preferences [14.3]. EBU-TT-D subtitles can be transported in MPEG-DASH as an additional stream. The text profile of IMSC1 [14.4] is an alternative approach for a TTML-based format by W3C, and is also considered as potential future candidate by DVB, especially for UHDTV [14.5]. It is to be noted that ITU-R SG 6 is working on a possible harmonization of both approaches, EBU-TT and IMSC1, in order to reach a unique worldwide specification for subtitles in digital television (especially important for the international exchange of programmes).

14.5 The special importance of IBB (Integrated broadcast-broadband) systems

Access services can, but do not have to be, made available together with the broadcast signal, i.e. as components of the digital broadcast multiplex. In principle, a hybrid approach is possible in all cases, provided the TV set or the set-top box can additionally be connected to the Internet: Integrated broadcast-broadband (IBB) systems allow the provision of access services via the online interface of smart (connected) TV sets or set-top boxes (see Figure 14.1). See Chapter 10 for more detailed information on IBB systems.

⁵⁶ HBB4ALL – The new Avatar Signing Application, Newsletter 6, <http://www.hbb4all.eu/hbb4all-newsletters/>

FIGURE 14.1

Principle of IBB: Interlinking of broadcasting programme and portal services by the broadcaster (Example here HbbTV)

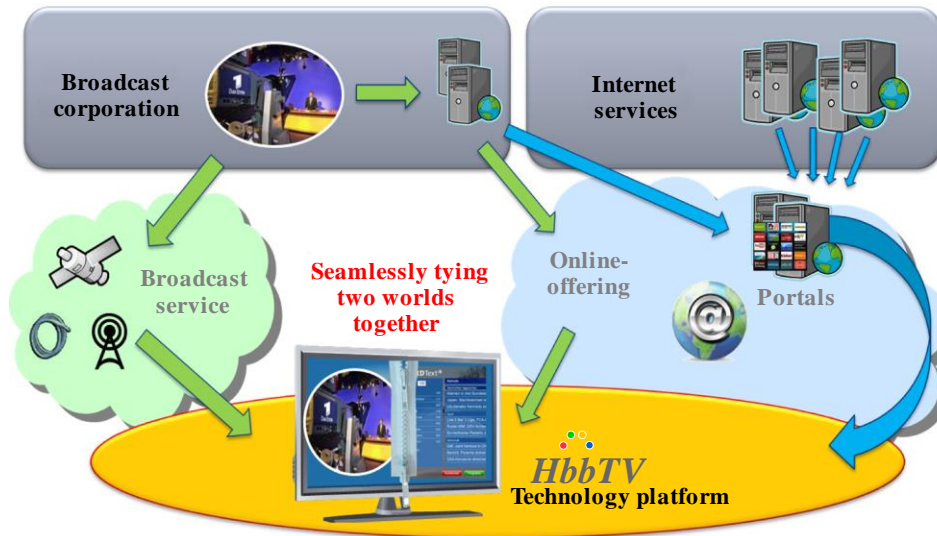

DTTB-14-01

IBB systems are of paramount importance for the retrieval and delivery of access services. Recommendation ITU-R BT.2075 [14.10] recommends the European system “HbbTV Version 1.5 and Version 2.0”, the Japanese system “Hybridcast” as well as the Korean system “HTML5 based Smart TV Platform”. In this Recommendation, access services via IBB are specifically mentioned. Prior to the approval of Recommendation ITU-R BT.2075, a Recommendation was issued on “Technical requirements for IBB systems” (Rec. BT.2053) [14.11] as well as a Recommendation on “General requirements for broadcast-oriented applications of integrated broadcast-broadband systems and their envisaged utilization” (Rec. BT.2037) [14.12]. In addition, the ITU-R Report BT.2267 “IBB systems” [14.13] gives examples how IBB can be applied to enable sign language, audio description or personalized (consumer-adjustable) subtitles (see Figure 14.2). Specific information with respect to HbbTV can be found in [14.6].

FIGURE 14.2

Test service for subtitles over IBB

The screen shot shows the menu for selecting size, background and position of subtitles delivered via the Internet (The example selects subtitles at the bottom of the TV image, with medium font size and on a black background of 85% of transparency.)



DTTB-14-02

14.5.1 Broadcast multiplex versus IBB services

Access services via IBB are more apt to personalization than access services that are transported in the broadcast multiplex (owing to the web techniques used). A drawback is, however, the need for the broadband Internet connection. In reality, a balanced mix is applied. Subtitles or audio-description in the principal language of the target audience are usually transmitted together with the broadcast signal. Video of sign-language interpretation, however, is often made available via IBB because of its relatively high demand for data-rate. In case a second video player is available in the end-user receiver, the sign-language video, which is retrieved via IBB, can be mixed (for example as alpha-blend or in a separate window) with the ongoing TV programme as depicted in Figure 14.3. The IBB system can normally take care of the proper synchronization.

FIGURE 14.3

Example sign-language video using IBB



DTTB-14-03

News via TV broadcasting, sign-language video via the Internet – The window of the sign-language video can be adjusted in size and position. Both videos are time-synchronized.

14.5.2 When IBB solutions are not practical (no broadband connection)

IBB systems like HbbTV or Hybridcast are key when it comes to access services. Nevertheless, ITU-R and ITU-T have also to consider, in liaison with ITU-D, solutions for countries (or situations) where people do not have (yet) access to broadband connections. One solution is to use a large part of the Data Carousel (DSM-CC) for additional content that, in this configuration, would be pushed over the broadcasting network (“push video-on-demand”). Of course, this reduces the number of TV programmes within such a multiplex but provides a number of additional services and information.

An elegant solution to provide IBB (for example HbbTV) subtitles is to insert them in the DSM-CC. This would take no more than about 10 to 20 kbit/s but would allow IBB-enabled receivers to display these subtitles in case of no Internet connection. Furthermore, in this case, there is no need for time synchronisation between the broadband and the broadcast signal as all information is contained in the broadcast multiplex.

Another option for larger amounts of data may be the usage of the File Delivery Protocol (FDP), which is, for example, available in HbbTV Version 2.0. FDP allows content to be pushed to a TV SSD or hard disk store during periods when the whole broadcast multiplex is not needed for TV programmes (e.g. during the night). Such files could contain specific content for people with special needs, for example audio description for a broadcast programme to come. In the case that a second video player is available in the set-top box or in the TV set, even a sign-language video could be stored prior to the TV broadcast and displayed together with the broadcast signal when this is transmitted on the following day(s). HbbTV 2.0 would take care of the necessary synchronization.

In case a second video player is not incorporated in the consumer TV device, broadcasters can insert the video of the sign-language interpreter at the studio and transmit this composite stream either within the broadcast multiplex (in simulcast with the TV programme without the sign language interpreter), or make it available as a video stream in the IBB configuration. In both cases, neither a second video player nor synchronization of the broadcast and the broadband stream is required. Customization by the end-user (e. g. selection of size or position on the screen of the sign-language video) is of course no longer possible.

Sometimes, an alternative can be to represent the online access services on a second screen such as tablet PC or smartphone and, again, synchronize both the broadcast and the broadband stream (see Figure 14.4). For example, this may be useful for audio-description when the person who needs this service listens to the audio-track that contains audio-description while other members of the family or group listen to the regular TV sound without audio-description. Thus, real e-inclusion can be practiced.

FIGURE 14.4

Principle of the Second Screen Framework⁵⁷

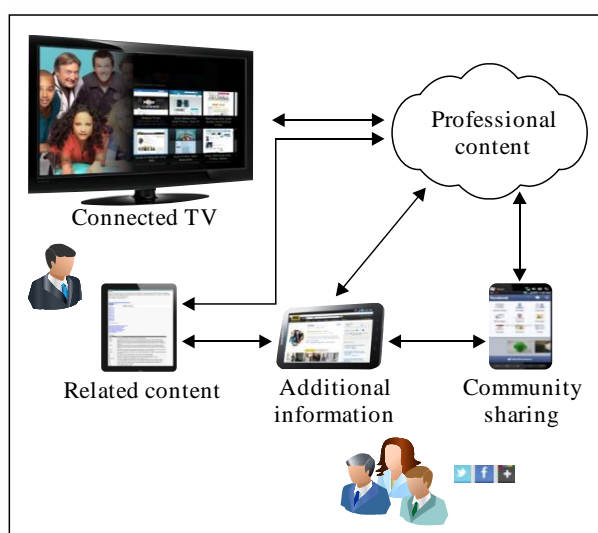

DTTB-14-04

14.6 Production of access services – some aspects

Another aspect concerns the production and the quality assessment of access services. Making it mainstream also means making it cost-efficient and making it available to all of us. Cost-efficiency can only be achieved for standardized products and procedures. Access services should be planned and included in the daily audio-visual production and, only exceptionally, be subject to special and costly post-productions. Also, for the international exchange of programmes, standardized solutions are more than desirable, quasi a prerequisite.

14.7 Conclusions

Agreed standards for access services are one factor that ensure the economy of scale necessary for affordable and interoperable audio-visual devices to be accessed by the public. The other factor is the general integration of these solutions in everybody's consumer devices. Only then can access services be made broadly available and to the benefit of all citizens.

⁵⁷ Diagram courtesy of EC project FI-CONTENT [14.7].

With perhaps the exception of sign-language, all access services provided by broadcasters for people with disabilities benefit us all. Children, minorities and foreigners profit from subtitles (for their understanding but also for learning reading and foreign languages); audio-description helps to understand a TV programme when watching the screen is difficult (e.g. while driving or doing house-work); clean audio and reduced audio speed improve the audio intelligibility under unfavourable listening or recording conditions.

Broadcasters, consumer-equipment manufactures and standardization bodies must continue to cooperate. Some functions can be left to the manufacturers (for example gesture or voice control of the TV set); others – those of a service nature – need to be standardized in order to ensure the continued implementation of access services and systems for the benefit of people with disabilities and for us all. ITU is, as a special agency of the United Nations, best placed to assist the world with pertinent standards and specifications.

Developments to assist people with special needs will continue especially with respect to personalisation (for example the adjustment of text colour for users with colour blindness or the rendering of audio objects in accordance with the aural properties of people with reduced hearing acuities). The hope is that future video technologies such as virtual and augmented or mixed reality or the use of depth information in 3D (holoscopic) systems will further help people with disabilities in their media consumption. The most important requirement is to make access systems mainstream (so that everybody can take advantage of them) and to develop quality standards for access services.

Bibliography to Chapter 14

- [14.1] **World Health Organisation (WHO)** – *World report on disability*, 2011, ref. http://www.who.int/disabilities/world_report/2011/en/
- [14.2] **NEM** Position Paper on Access Policy Suggestions – *Opening doors to Universal Access to the Media*, February 2016, ref. <http://nem-initiative.org/wp-content/uploads/2016/03/NEM-ACCESS-Policy-suggestions.pdf>
- [14.3] **EBU TT**, ref. <https://tech.ebu.ch/ebu-tt> and https://tech.ebu.ch/docs/factsheets/ebu_tech_fs_ebu-tt.pdf
- [14.4] **W3C** Recommendation – *TTML Profiles for Internet Media Subtitles and Captions 1.0 (IMSC1)*, 21 April 2016, ref. <https://www.w3.org/TR/ttml-imsc1/>
- [14.5] **Peter Cherriman** *Subtitling for UHDTV*, DVB Scene No. 48 (Sept. 2016), ref. <https://www.dvb.org/resources/public/scene/dvb-scene48.pdf>
- [14.6] **Christoph Dosch** *Convergence of Broadcasting and Broadband Internet – A Benefit for People with Disabilities (and for us all)*, ITU Academic Conference Kaleidoscope 2014, St. Petersburg, Conference proceedings, pp. 89-95, ref. <https://www.itu.int/en/ITU-T/academia/kaleidoscope/2014/Documents/Kaleidoscope2014Proceedings.pdf>
- [14.7] <http://www.fi-content.eu/> and <http://mediafi.org/>
- [14.8] **ETSI** EN 300 472 V1.3.1 (2003-05) – *Digital Video Broadcasting (DVB); Specification for conveying ITU-R System B Teletext in DVB bitstreams*
- [14.9] **ETSI** EN 300 743 V1.5.1 (2014-01) – *Digital Video Broadcasting (DVB); Subtitling systems*
- [14.10] **ITU-R**, Recommendation ITU-R BT.2075, *Integrated broadcast-broadband system*
- [14.11] **ITU-R**, Recommendation ITU-R BT.2053, *Technical requirements for integrated broadcast-broadband systems*
- [14.12] **ITU-R**, Recommendation ITU-R BT.2037, *General requirements for broadcast-oriented applications of integrated broadcast-broadband systems and their envisaged utilization*
- [14.13] **ITU-R**, Report ITU-R BT.2267, *Integrated broadcast-broadband systems*

PART 3

CONTRIBUTION AND ENG ASPECTS FOR DIGITAL PROGRAMME PRODUCTION

Introduction to Part 3

Just as broadcasting systems do, so systems for television production are constantly evolving. As for the broadcasting service, there are continuous improvements in transmission and audio-visual coding and processing techniques as well as in the associated handling of data and metadata.

With the introduction of digital technologies in signal capturing, forming and linking to the studio, the efficiency of such systems has grown. Outside Production, Outside Broadcasting and Electronic News Gathering need to keep pace with the introduction of HDTV, UHDTV or stereoscopic TV (3DTV) technologies in the consumer domain. Modern efficient transmission technologies such as DVB-T2 and efficient compression schemes for the audio-visual information (e.g. MPEG HEVC and HE-AAC v2) allow programme material to be provided in the highest quality formats over terrestrial channels. Consequently, there is a clear move towards all-digital solutions.

The characteristics of the television production and post-production systems substantially influence the characteristics of the broadcast television signal end-to-end. However, the requirements for contribution and news gathering systems often differ from those for the broadcasting service. Signal robustness or the delay time between content generation and delivery have a great influence on the choice of parameters. Another aspect concerns the need for mobility in contribution and news gathering.

Services Ancillary to Programme-making and Broadcasting often have a very high requirement for quality, for example in the case of wireless microphones. Many such PMSE systems share, for their transmission, the UHF broadcasting bands. Others make use of the mobile service bands or use terrestrial or satellite fixed transmissions.

Part 3 contains only one Chapter; however, the information is of importance for television production and the (international) exchange of broadcast content and programmes. Part 3 gives information on Outside Production, Electronic News Gathering as well as on various forms of signal contribution. A specific section deals with experiences in gathering and handling 4k and 8k UHDTV signals.

CHAPTER 15

Contribution and news gathering systems

15.1 Introduction

An important component of television technology is programme production and outside broadcasting, providing and distributing program material to studios and/or directly to a secondary distribution network of terrestrial transmitters. Development of these systems occurs continuously and dynamically together with other parts of the television chain, with the development of transmission and processing technologies.

Nowadays in television applications either analogue or digital systems for information gathering and processing are used. The choice of audiovisual information format is defined by the development stage of programme production and outside broadcasting. Complete transition to digital technologies will occur in the process of transition to digital of distribution systems and other parts of the television chain.

For gathering of news and contribution of program material to a studio, all the existing environments (terrestrial, cable or satellite) may be used. Any combination of the listed environments could also apply. The application of certain type of environment or their combinations is determined by the requirements of the transmitted application (the required channel capacity, the criticality of delivery time, the distance between the audiovisual information gathering equipment, the location of the event being covered, etc.).

An important component of these applications' requirements is the degree of mobility and available frequency resource that can be used for the purpose of programme production and outside broadcasting. In this connection, applications for programme production and outside broadcasting may be organized within broadcast (BS), mobile (MS) or fixed (FS) services.

Depending on scope of the television application within which programme production, outside broadcasting and other related applications are used, it is possible to classify services as follows:

- Services Ancillary to Programme-making (SAP);
- Services Ancillary to Broadcasting (SAB).

These services are defined as follows (according to Report ITU-R BT.2069 [15.1]):

Services Ancillary to Programme-making (SAP) support the activities carried out in the making of “programmes”, such as film making, advertisements, corporate videos, concerts, theatre and similar activities not initially meant for broadcasting to general public.

Services Ancillary to Broadcasting (SAB) support the activities of broadcast service companies carried out in the production of their programme material.

SAB were originally just those required by public broadcasting companies in the preparation of programme material, while SAP covered programme-making by independent companies along with commercials, theatre shows, concerts and sporting events. While there are some differences in the nature of these two businesses, their spectrum requirements are almost identical.

The SAP/SAB definitions imply more business-oriented classification of programme making facilities. The technical view then adds another dimension to that picture because many SAP and SAB users use the same technology for their applications. Therefore, the following picture in Figure 15.1 describes this two-layered structure of SAP and SAB, including ENG/OB applications.

The following definitions are assumed in describing the technology layer of various SAP/SAB applications.

TABLE 15.1

Definitions of SAP/SAB Applications

Term	Definition
Wireless microphone	Hand-held or body-worn microphone with integrated or body-worn transmitter. User requirements for wireless microphones are provided in [15.23].
In-ear monitor	Body-worn miniature receiver with earpieces for personal monitoring of single or dual channel sound-track.
Portable audio link	Body-worn transmitter used with one or more microphones, with longer operating range capabilities than that of wireless microphones.
Mobile audio link	Audio transmission system employing radio transmitter mounted in/on motorcycles, pedal cycles, cars, racing cars, boats, etc. One or both link terminals may be used while moving.
Temporary point-to-point audio link	Temporary link between two points (e.g. part of a link between an OB site and a studio), used for carrying broadcast quality audio or for carrying service (voice) signals. Link terminals are mounted on tripods, temporary platforms, purpose built vehicles or hydraulic hoists. Two-way links are often required.
Cordless camera	Hand-held or otherwise mounted camera with integrated transmitter, power pack and antenna for carrying broadcast-quality video together with sound signals over short-ranges.
Portable video link	Hand-held camera with separate body-worn transmitter, power pack and antenna.
Mobile airborne video link	Video transmission system employing radio transmitter mounted on helicopters or other aircraft.
Mobile vehicular video link	Video transmission system employing radio transmitter mounted in/on motorcycles, pedal cycles, cars, racing cars or boats. One or both link terminals may be used while moving.
Temporary point-to-point video links	Temporary link between two points (e.g. part of a link between an OB site and a studio), used for carrying broadcast quality video/audio signals. Link terminals are mounted on tripods, temporary platforms, purpose built vehicles or hydraulic hoists. Two-way links are often required.
Talk-back	For communicating the instructions of the director instantly to all those concerned in making the programme; these include presenters, interviewers, cameramen, sound operators, lighting operators and engineers. A number of talk-back channels may be in simultaneous use to cover those different activities. Talk-back usually employs constant transmission.
Telecommand/remote control	Radio links for the remote control of cameras and other programme-making equipment and for signalling.

FIGURE 15.1
Overall picture of SAP/SAB user sectors and applications

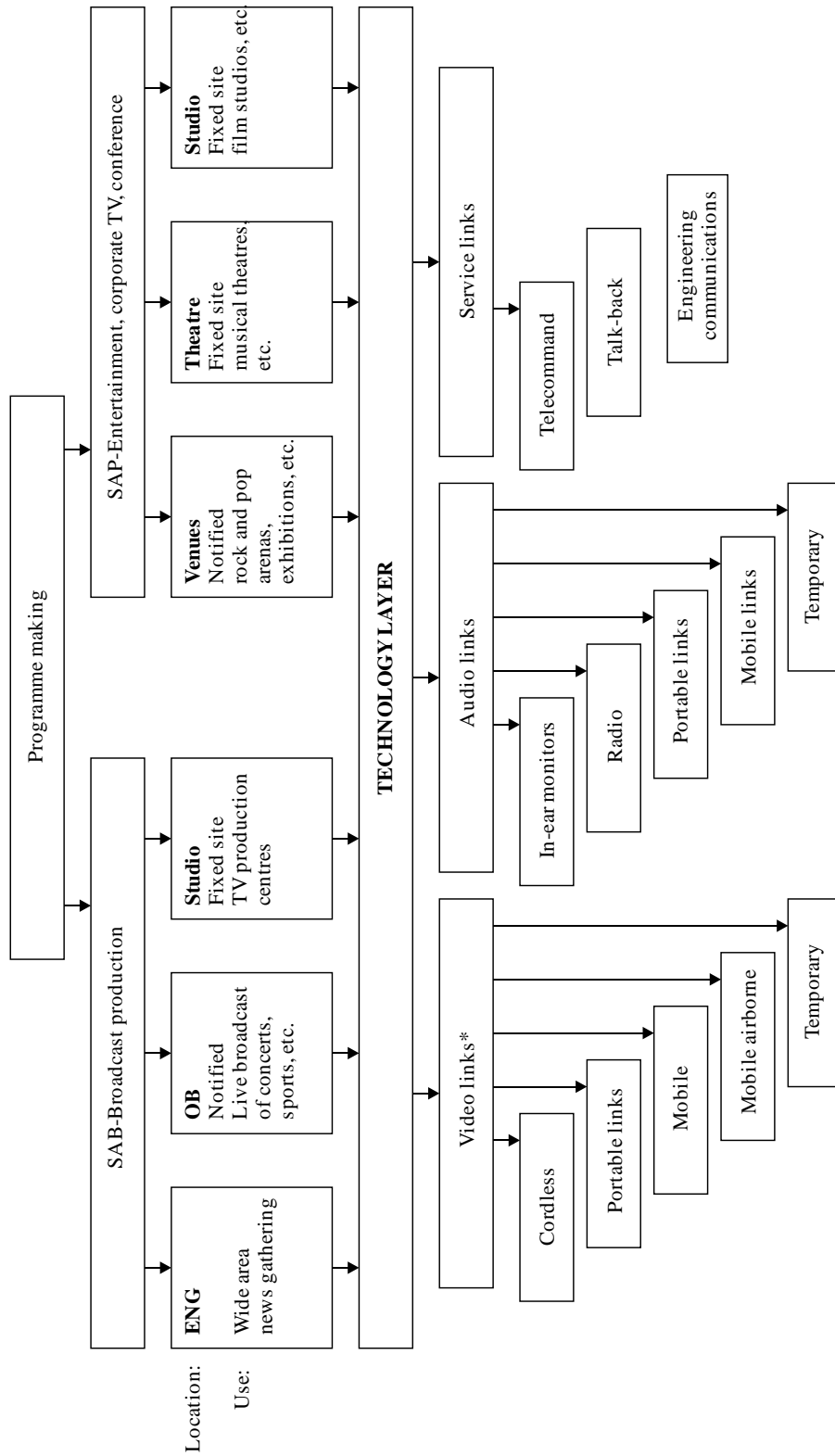

* Note— Video links often incorporate audio circuits for sound programme transmission.

15.2 Terrestrial News Gathering and Contribution

15.2.1 General concepts

Electronic news gathering (ENG) is used to collect video and/or sound material without the use of film or tape recorders, using small, often hand-held, electronic cameras and/or microphones with radio links to the news room and/or to portable tape or other recorders.

With the application of digital technologies and the more effective methods of compression those allow, the bit-rate required for transmission of a broadband television signal may be reduced, so the scope of news gathering systems covers not only standard definition (SDTV) and a high definition (HDTV) television, but can be extended to ultra-high definition (UHDTV) television.

15.2.2 User requirements for terrestrial news gathering and contribution

The requirements for terrestrial news gathering and contribution includes different aspects such as source coding, image and sound quality, bit-rate and frequency requirements etc. The definition of such requirements should be implemented taking into account the continued progress in digital television technologies such as source coding, transmission and so on. The situation with the introduction of digital terrestrial news gathering and contribution systems is very diverse, and currently analogue and digital SAP/SAB systems co-exist. In parallel, DTTB introduction is in progress. All this and many other factors add some limitations on requirements for terrestrial news gathering and contribution systems for some period of time. ITU Recommendations, Reports and other documents contain such requirements and limitations for terrestrial news gathering and contribution (see bibliography). Some basic requirements are provided in the paragraphs below.

15.2.2.1 User requirements for HDTV/SDTV terrestrial news gathering

Recommendation ITU-R BT.1868 [15.2] provides user requirements for codecs for transmission of television signals through contribution, primary distribution, and ENG/SNG networks.

Table 15.2 contains user requirements that should be applied to the specification, design, and testing of systems for the transmission of television signals through contribution, primary distribution and ENG/SNG networks as part of the broadcasting chain.

TABLE 15.2

User requirements for codecs for transmission of television signals

Type of transmission network	Contribution	Primary distribution	SNG/ENG
Input video signal format	Sampling: 4:2:2 (Y, C_B, C_R) 8 or 10 bits per sample for each component		
Input audio signal format	Sampling: 48 kHz 20 bits or more	Sampling: 48 kHz 18 bits or more	Sampling: 48 kHz 16 bits or more
Sound channel	Eight channels (typical)	Six channels (typical)	Two channels (minimum)
Ancillary data	Bit rate: around 100 kbit/s		
Maximum relative sound/ vision delay	± 2 ms per codec		

TABLE 15.2 (end)

Type of transmission network	Contribution	Primary distribution	SNG/ENG
Basic picture quality (for the given number of codecs in tandem in error-free condition) (2)	Three codecs in tandem	Two codecs in tandem	Single codec
	Quality difference: $\leq 12\%$ with double stimulus continuous quality scale (DSCQS) method using at least four sequences taken from Recommendation ITU-R BT.1210, at least half of which should be high-activity sequences. The given quality grade should be met using at least 75% of the sequences chosen; the rest must achieve $\leq 20\%$		
Optional requirement for picture quality (for the given number of codecs in tandem in error-free condition)	not applicable	not applicable	Two codecs in tandem
			Quality difference $\leq 18\%$ of the DSCQS or at least four sequences chosen from Recommendation ITU-R BT.1210, at least half of which should be high activity sequences. The given grade should be met using at least 75% of the sequences chosen, the rest should achieve $\leq 36\%$
Picture quality after colour matte, after modification to picture geometry, or after slow motion	Quality difference: $\leq 18\%$ with DSCQS method using two foreground sequences and appropriate background material taken from Recommendation ITU-R BT.1210, between two codecs	not applicable	not applicable
Basic sound quality	See Recommendation ITU-R BS.1548 [15.3], Annex 1		
Failure characteristic/error performance	Quasi-error-free at decoder input for normal condition. Error-concealment functionality should be required for decoders. A signalling function for errors should be provided.		
Vision/audio failure characteristics	Vision failure first		
Recovery time	≤ 500 ms after a break of 50 ms		< 1 s after a break of 50 ms
Change in overall delay after signal interruption/ major disturbance	Less than 20 μ s		

For more details, see [15.2].

Requirements for source coding for terrestrial news gathering in terms of image and sound resolution are defined in Recommendation ITU-R BT.1203 [15.4]. Table 15.3 contains such requirements for contribution and terrestrial news gathering for H.262/H.264/H.265 codecs.

TABLE 15.3

Functional and operational requirements for H.262/H.264/H.265 codecs

Items	SNG/ENG			Contribution		
	Mode 1 ⁽¹⁾	Mode 2 ⁽²⁾				
No. of samples/line and No. of lines/frame (examples)	SDTV: 720 × 576 in 50/60 Hz environment with progressive or interlaced scanning HDTV: 1 280 × 720 in 50/60 Hz environment with progressive or interlaced scanning HDTV: 1 920 × 1 080 in 50/60 Hz environment with progressive or interlaced scanning					
Colour format	4:2:2 or 4:4:4 should be used for the digital interface					
No. of audio channels BT.709/HDTV BT.1543/ BT.1847 BT.601 and BT.1358/SDTV	Minimum 2 Minimum 2 Minimum 2			Maximum 8 Maximum 8 Maximum 6		
Range of bit rates	Rec. ITU-T H.262	Rec. ITU-T H.264	Rec. ITU-T H.265	Rec. ITU-T H.262	Rec. ITU-T H.264	Rec. ITU-T H.265
BT.709/HDTV	Up to 140 Mbit/s	Up to 14 or 21 Mbit/s	Up to 7 or 12 Mbit/s	Up to 140 Mbit/s	Up to 35 or 48 Mbit/s	Up to 17 or 24 Mbit/s
BT.1543/ BT.1847	Up to 140 Mbit/s	Up to 14 or 21 Mbit/s	Up to 7 or 12 Mbit/s	Up to 140 Mbit/s	Up to 35 or 48 Mbit/s	Up to 17 or 24 Mbit/s
BT.601 and BT.1358/SDTV	Up to 34 or 45 Mbit/s	Up to 12 Mbit/s	Up to 6 Mbit/s	Up to 34 or 45 Mbit/s	Up to 12 Mbit/s	Up to 6 Mbit/s
Prediction mode	I, P (Rec. ITU-T H.262); I, P, B, Intra (Rec. ITU-T H.264)					
Picture quality (DSCQS)	12% ⁽³⁾		36% ⁽³⁾	12% ⁽⁴⁾		
Compatibility	Not required					
Hierarchical coding	Not required					
Scalability	Not required, however if needed then lower quality can be obtained with a spatial interpolator					
Interoperability	Not required					

NOTE 1 – Mode 1: good transmission conditions.

NOTE 2 – Mode 2: poor transmission conditions.

Table 15.3 uses the following definitions:

- *Generic coding*: digital coding of pictures based on family of related coding methods.
- *No. of samples/line*: number of luminance samples per active line.
- *No. of lines/frame*: number of vertical lines per active frame.
- *Colour format*: ratio between the number of the luminance pixels and the number of the co-sited chroma difference pixels or the ratio between the colour pixels *R*, *G* and *B*.
- *No. of audio channels*: total number of sound channels per programme, together with a description how these channels can be combined for different applications.
- *Range of bit rates*: minimum and maximum encoder output bit rates for several input formats.
- *Prediction mode*: type of prediction used inside the encoder. This influences very strongly the maximum achievable picture quality of following codecs.

- *Picture quality*: results of the subjective evaluation of the encoding and decoding performance in an error-free channel.
- *Compatibility*: description whether the bit stream syntax allows the separate signal processing of parts of the total bit stream in subsequent codecs.
- *Hierarchical coding*: method to achieve different resolution layers on the decoder side.
- *Scalability*: access to several picture qualities in a single bit stream.
- *Interoperability*: description of the grade of commonality between different bit streams inside the broadcasting chain.
- *Editability*: ability to edit a programme taking into account the structure of the encoder output data.
- *Bit-rate flexibility*: the coding algorithm may allow the use of either CBR (constant bit rate) – or VBR (variable bit rate) – coding.
- *Codec delay*: the delay introduced by the coding/decoding algorithm.
- *Recovery time*: the time period between a physical interruption inside the broadcasting chain and the achievement of full functionality.
- *Acquisition time*: the maximum acceptable waiting time from start of the decoding process until the display of the picture. This might influence the choice of the generic coding scheme.
- *Error concealment*: possibility of the decoder to react in a specified way to alarm signals coming from the FEC part of the decoder.
- *Graceful degradation*: to avoid an abrupt degradation of the picture quality on the decoder side, the output of scalable encoders can be protected by different FEC schemes or by non-uniform modulation schemes. A combination of both methods is also possible.
- *Channel hopping latency*: waiting time introduced by the switching between different TV channels.

Table 15.4 provides user requirements and technical parameters in terms of basic video and audio quality for transmission of digital HDTV/SDTV using ENG systems.

TABLE 15.4

**User requirements and technical parameters in terms of basic video
and audio quality for transmission of digital HDTV/SDTV signals**

Item	User requirements	Technical parameters
Basic video signal quality	Degradation of picture quality $\leq 12\%$ with DSCQS method as specified in [15.2]. (See also [15.4])	HDTV [15.19]:
		Video bit rate for 3 codecs in tandem: – 52 Mbit/s (using ISO/IEC 13818-2, H.262, 4:2:2P@HL) – 35 Mbit/s (using ISO/IEC 14496-10, H.264, Level 4/ High 4:2:2) – 75 Mbit/s (using ISO/IEC 23008-2 MPEG-H, H.265, Level 5/ High 4:4:4, 12 bit, see Rec. ITU-T H.265 [15.5]) (see Note 1)
		Video bit rate for single codec: 21 Mbit/s (using ISO/IEC 14496-10, H.264 Level 4/ High 4:2:2)
		SDTV [15.18]:
		Video bit rate: 15 Mbit/s (using ISO/IEC 13818-2, H.262, 4:2:2P@ML with long-GOP)
		Video bit rate: 10 Mbit/s (using ISO/IEC 14496-10, H.264, Level 3/High 4:2:2) Video bit rate: 18 Mbit/s (using ISO/IEC 23008-2 MPEG-H, H.265, Level 3/High 4:4:4, 12 bit) (see Note 1)
Basic sound signal quality	Audio quality ≥ 4.5 in the impairment 5° scale as specified in [15.3]. Comparable to uncompressed Linear PCM (48 kHz, 16 bit/ch).	Uncompressed 768 kbit/s per channel MPEG-1 layer II 250 kbit/s per channel MPEG-4 HE-AAC v2 with 96 kbit/s per channel

NOTE 1 – It is known that MPEG HEVC is more efficient than previous MPEG codecs. However, it is seen from that bit-rate for HEVC is higher than for MPEG-4 AVC. This is due to difference in digital encoding parameters – example for HEVC is provided for higher quality than for MPEG-4 AVC (for 4:4:4 and 12 bit per pixel). It is expected that bit-rate at MPEG HEVC output of for equal conditions (e.g. 4:2:2) is approximately half of bit-rate at MPEG-4 AVC encoder output.

15.2.2.2 User requirements for UHD TV terrestrial news gathering

The combination of new compression methods and high-efficiency digital terrestrial television transmission systems may lead to a widespread introduction of UHD TV. Currently UHD TV support is included in MPEG-4 AVC (UHD TV combinations of profile/ level correspond to Hi422P or Hi444P and L5.1) and HEVC compressions.

Table 15.5 provides some examples of user requirements and technical parameters in terms of basic video quality for transmission of UHDTV signals.

TABLE 15.5
User requirements and technical parameters in terms of
basic video quality for transmission of UHDTV signals

Item	User requirements	Technical parameters
Basic video signal quality	Degradation of picture quality as specified in [15.25]: For 75% of the sequences chosen: DSCQS \leq 12% For the rest: DSCQS \leq 30%.	UHDTV:
		Video bit rate for single codec (example): 960 Mbit/s (using ISO/IEC 14496-10, H.264 Level 5.1/ High 4:2:2 or High 4:4:4) 480 Mbit/s (using ISO/IEC 23008-2 MPEG-H, H.265 Level 5.1/ High tier 4:4:4 12 bits)

In recent years, many broadcasters and programme producers have started to make programmes in UHDTV. This section highlights some early pioneering experience of 4K UHDTV contribution undertaken in Italy as early as 2009, and some more recent 8K production experience from Japan.

15.2.2.2.1 Italian production experience, 2009

In September 2009 the RAI Research Centre demonstrated the live transmission of 4K video over a digital terrestrial channel in the Turin area [15.24]. This is also the maximum resolution we can afford on a digital terrestrial channel using today's most advanced technologies with MPEG-4 picture coding and the DVB-T2 transmission format. For this purpose, a twelve minute 4K video clip was specially produced by the RAI Production Centre in Turin using a mix of artistic and real-life shots in Turin. The purpose of the 4K production at RAI was to explore the typical conditions for television production in the field, employing TV professionals limited to short production times in mostly uncontrolled environments typical of live scenes.

A Red One, 4K format camera (4096 \times 2304 pixel at 25 frames/s in progressive scan), with mounted Angenieux zoom-lenses (HR 25-250 T3.5 and 17-102 T2.9 models) was used for the shoot. The Red One is equipped with a 12 Mpixel Bayer sensor (same size as Super 35 mm format) and the video signal is compressed with JPEG2000 technology at 288 Mbit/s and stored on embedded hard disk drives. For monitoring purposes only an HD version live signal (1280 \times 720p50) was available to the camera operators and the artistic assistants.

For delivering the content, state-of-the-art technologies were required for encoding, transmission, decoding and display. Therefore, the choice was the DVB-T2 standard which provides sufficient capacity to deliver 4 HDTV (1920 \times 1080) signals in a terrestrial UHF channel. This is equivalent to an aggregate resolution of 3840 \times 2160, which is actually very similar to the resolution provided by the Red One 4K camera. So, after scaling from 4096 \times 2304 to 3840 \times 2160 pixels with 25 Hz progressive scanning, the resulting video clip was then split into four full-HDTV (1920 \times 1080) streams, each one software encoded using H.264 technology (High Profile Level 4). The four 1920 \times 1080 streams resulting from the encoding were then multiplexed to produce a multiprogram Transport Stream. Different configurations of useful bit rates were produced – 36 and 45 Mbit/s.

FIGURE 15.2
RAI experience in UHDTV terrestrial transmission



DTTB-15-02

Particular attention was given to maintain the synchronization of the streams throughout the whole end-to-end chain in order to make the 4-quadrant splitting of the picture undetectable on screen. In the near future, the use of H.264 with High Profile Level 5.1, currently under testing, will be capable of handling the entire 4K frame, thus removing any synchronization issues.

A real transmission on channel 29 UHF from the Torino-Eremo transmission site was carried out using DVB-T2 with the following parameters: 256QAM constellation, 32K OFDM mode, and Guard Interval 1/128. Two different FEC values were used in order to test two different configurations with a useful bit-rate ranging from about 36 Mbit/s (FEC 3/5) to 45 Mbit/s (FEC 3/4), therefore allowing an average capacity for each of the four HDTV streams from 9 to 11 Mbit/s. The four HD quadrants were reassembled and displayed using both an Astro Design, DM-3400, 4K × 2K (3840 × 2160) 56 inch LCD monitor and a high performance Sony 4K digital cinema projector providing really impressive pictures on a 200 inch screen.

15.2.2.2.2 Japanese 8K production experience

A more recent example of terrestrial UHDTV news gathering transmissions in Japan is provided below [15.9]. The transmission of uncompressed video and audio signals (baseband signals) from a camera is an essential requirement of live production in the field, and UHDTV will be no exception. Taking the high bit rate of uncompressed UHDTV signals into account, a huge amount of additional capacity will be needed. The frequency bands now being used for temporary HDTV video links are used heavily by existing services and have no potential for future expansion.

A UHDTV temporary video link using the 120 GHz band has therefore been developed in Japan to make use of the wider bandwidth and higher capacity of the millimetre band. This 120 GHz video link will carry uncompressed Dual Green 8K signals (formatted with the Bayer colour filter array, which has very similar quality to full 8K) with a data rate of 24 Gbit/s.

Temporary video links can be used when it is difficult or unfeasible to use a cable, such as in a stadium, on a golf course, or in the case of some huge obstacle.

Figure 15.3 to Figure 15.5 show examples of usage in a stadium (transmission distance at 250 m), golf course (transmission distance at 1 km) and transmitting over obstacles (transmission distance at 4 km).

FIGURE 15.3
Stadium

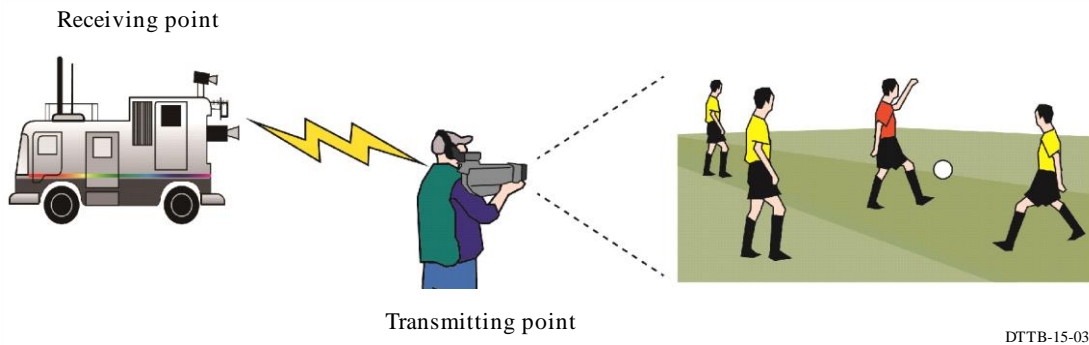

FIGURE 15.4
Golf Course

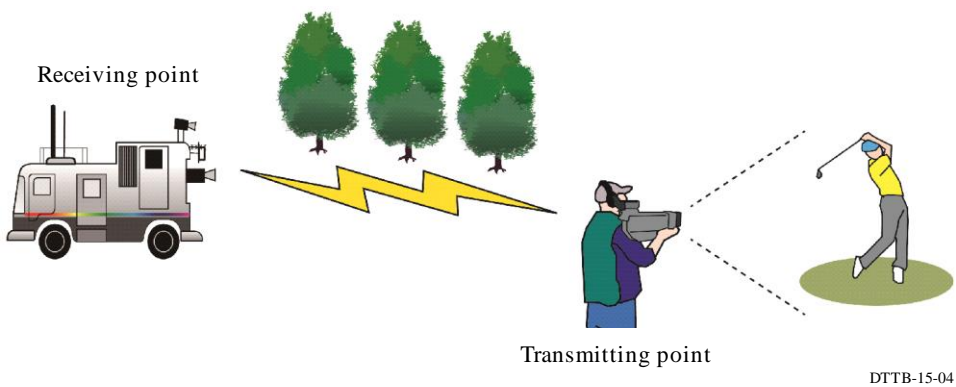
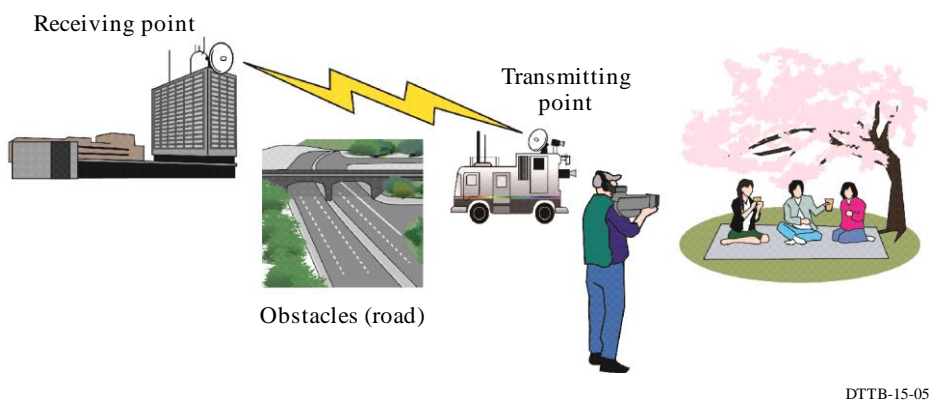

FIGURE 15.5
Transmission over obstacles



As shown in Figure 15.6, 16 HD-SDI signals consisting of the Dual Green 8K signal are multiplexed into two groups. Each group containing eight HD-SDI signals is transmitted by either vertical or horizontal polarization of the 120 GHz band video links.

The major advantage of the 120 GHz band video link is its high transmission capacity. The uncompressed 8K signal is all contained in the 17 GHz bandwidth. The use of uncompressed transmission maintains the full video and audio quality of 8K, as well as minimizing the transmission latency.

FIGURE 15.6
Overview of the temporary 120 GHz band video link for 8K

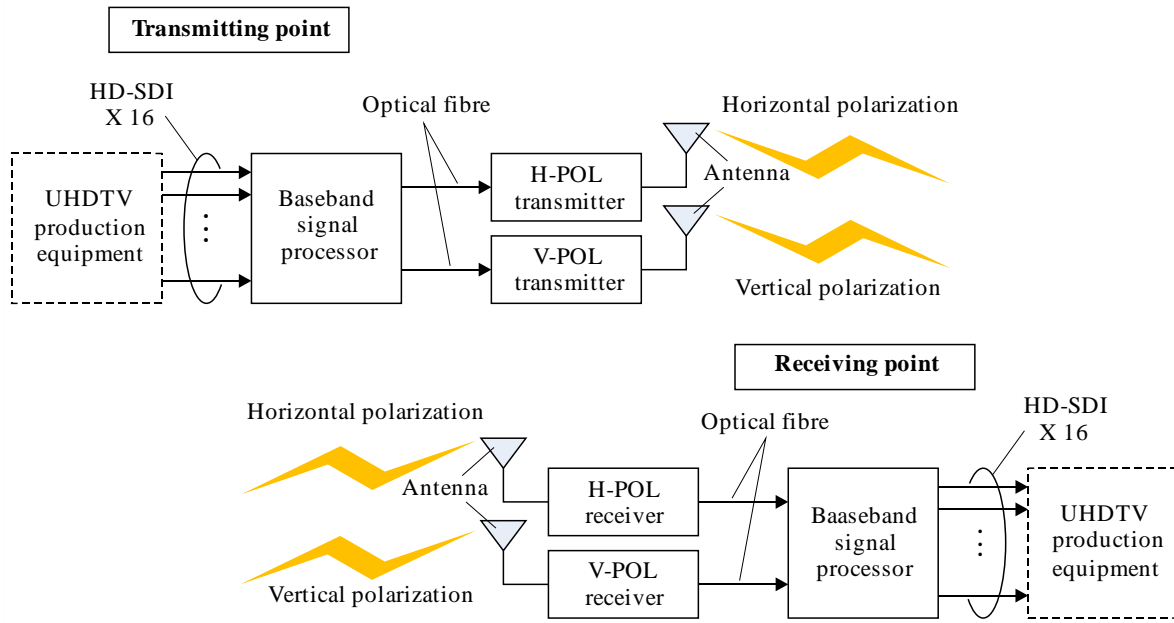

DTTB-15-06

Reed-Solomon Code (986, 966) for error correction is implemented when the baseband processor multiplexes the 8 HD-SDI signals into a single serial data stream (at the receiving end, this serial data stream is demultiplexed into the original 8 HD-SDI signals and errors which arose during propagation are corrected up to BER = 1×10⁻⁴). This improves the required C/N by approximately 4 dB compared with when no error correction is implemented.

The technical parameters of the temporary video link are shown in Table 15.6.

TABLE 15.6
Technical parameters of the 120 GHz band temporary video link

Centre frequency (GHz)	125		
Bandwidth (GHz)	18 (116 – 134)		
Polarization	Horizontal, vertical, circular		
Maximum Tx power (W)	1.0		
Modulation	ASK	BPSK	QPSK
Maximum bit rate (Gbit/s)	12.0	12.0	24.0
Required Rx input level (dBm)	-30.4	-36.4	-31.5
Required C/N* (dB) (Note 1)	25.0	19.0	23.9

NOTE 1 – In case without error correction.

8K public viewing of the 66th Sapporo Snow Festival was staged in February 2015. The site survey revealed that no optical cable was available between the festival site and public viewing venue, and the use of a temporary cable was unfeasible due to heavy traffic on roads around the site.

The use of a temporary 120 GHz band video link was therefore selected for this public viewing and the system was configured in the same manner as for the live broadcast. The system diagram is shown in Figure 15.7.

FIGURE 15.7
System diagram for 8K public viewing

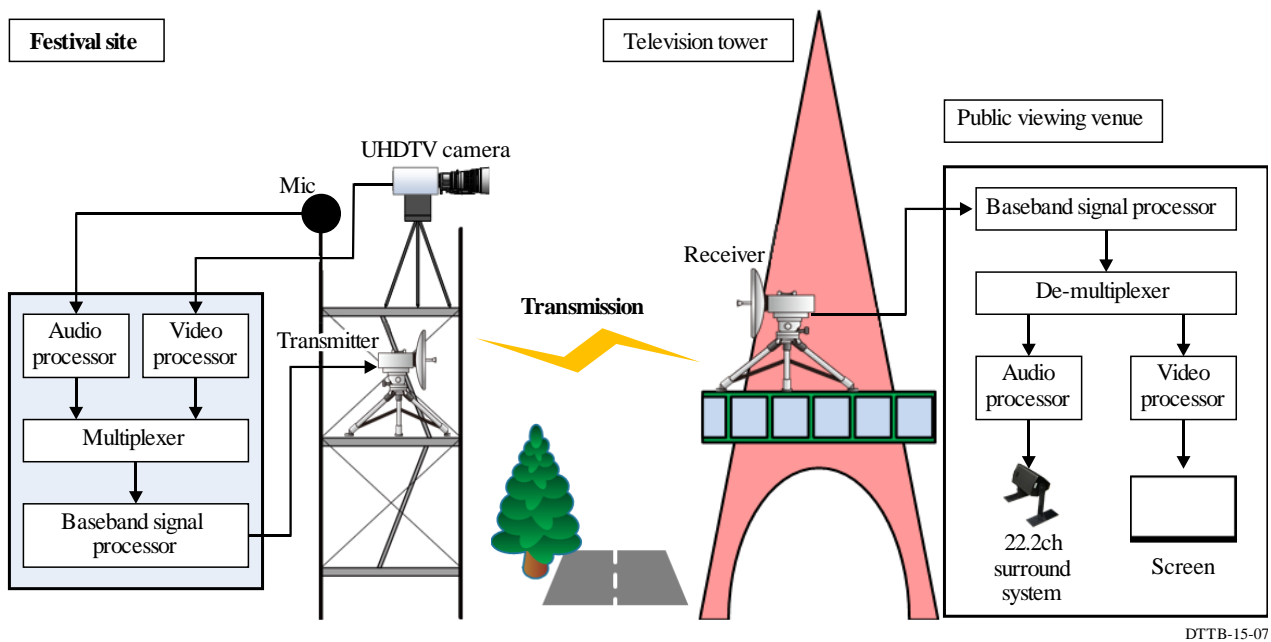

The 8K UHDTV signals were multiplexed in the production booth near the festival site, and sent to the transmitters using optical fibre. The temporary 120 GHz band video link then transmitted the signals to the other side of the road across a distance of approximately 160 m. Once received at the television tower, the signals were then sent on to the public viewing venue over an existing optical fibre link (see Figure 15.8).

FIGURE 15.8
Transmitter and receiver



Rainy weather was experienced during this 120 GHz band video link trial. Millimeter waves are very susceptible to influence from rainfall due to their short wave length and attenuation of approximately 4 dB was recorded for both polarizations. This trial, however, was designed with a 17 dB C/N margin and this was sufficient to transmit the 8K signals without uncorrectable errors. In addition, heavy snowfall was experienced during the event, but with no evident impact on the reception power. This trial confirmed that the 120 GHz band video link for 8K UHDTV does have the potential for use even in difficult weather conditions.

Other useful example is provided in Report ITU-R BT.2246 – The present state of ultra-high definition television [15.26].

15.2.3 Frequency requirements for terrestrial news gathering

ENG operates terrestrially in bands allocated to the broadcasting, fixed and mobile services.

The very nature of ENG in a competitive environment can involve several broadcasters/organizations/networks attempting to cover the same situation in a geographic area, requiring several radio-frequency channels to operate simultaneously often over the same radio path. Co-siting requirements of multiple ENG links, while covering an event, need to be met.

The specific frequency bands used for ENG have a number of inherent technical attributes which are beneficial. However, there may be offsetting conditions or spectrum management issues which may be harmful for ENG deployments. For example, ENG operating in radio-frequency spectrum bands below 3 GHz tend to provide better propagation characteristics over obstructed paths, thereby increasing the probability of a successful transmission from a particular event. In addition, new digital equipment can be used for higher velocity mobile applications at these lower frequency bands. However, with the growth in the use of frequency bands between 500 MHz and 10 GHz by many radiocommunication services, there is the possibility of increased congestion and interference in the same geographic area from other services which may hinder ENG equipment use in these lower frequency bands. On the other hand, use of higher frequency bands could impose severe constraints in adverse weather conditions. It must also be taken into account that demand for required frequency resource for current and future applications is constantly raising.

The tuning range is considered a basic parameter for the definition of frequency requirements. The term “tuning range” for ENG means a range of frequencies over which radio equipment is envisaged to be capable of operating. Within this tuning range, the use in any one country of radio equipment from another country will be limited to the range of frequencies identified nationally in that one country for ENG, and will be operated in accordance with the related national conditions and requirements. Identification of a tuning range for ENG does not preclude the use of other applications in the same frequency range nor establish priority over any other use of these bands. Administrations provided some information on frequencies/frequency bands and preferred tuning ranges used for ENG applications. This information is provided in [15.1].

The definition of frequency requirements is based on two approaches – harmonization and rationalization. The terms “harmonization” and “rationalization” are defined as follows:

Rationalization: Using available technology to maximize efficient and flexible use of frequencies. This means using equipment standardization and advanced technologies to ensure the most efficient use of frequencies within administrative regulations when equipment is deployed.

Harmonization: Global or regional agreement to employ a harmonized spectrum use in specific bands.

In order to assess the feasibility of harmonization of frequency bands, the ENG applications can be broadly divided into:

- video applications;
- audio applications.

In the absence of any meaningful frequency harmonization from one country to another, there is enormous diversity of ENG equipment available from manufacturers in a range of frequency bands. As a result, broadcasting organizations must possess diverse equipment in many of these frequency bands in order to travel from one country to another. This may potentially be alleviated through the use of advanced technology which would reduce cost for broadcasting organizations, give economies of scale for equipment manufacturers and reduce interference possibilities.

Some administrations consider that spectrum rationalization, depending on the specific ENG application, may be more productive in allowing foreign broadcasters and/or ENG operators, as appropriate, knowledge of and access to the required spectrum in a given country/region. This information would assist broadcasters and/or ENG operators to seek licensing prior to planned news events, allowing them access to spectrum when required. This information would also assist broadcasters and/or ENG operators to seek licensing for coverage of emergency news events. These measures would ensure that events can be covered. Studies have focused on the bands already used for ENG applications. The tuning ranges required to facilitate cross-border ENG requirements from other administration may be considerably less than the host administration’s national requirements.

Spectrum harmonization may provide many benefits such as reduced cost for broadcasting organizations, economies of scale for equipment manufacturers, and reduced interference possibilities. It does not imply ready access to spectrum within individual administrations. Spectrum access is only available through administration policies and regulations. The feasibility of such harmonization would have to take into account the disparate use of spectrum by the many countries involved and the differing ENG characteristics in use in administrations.

15.2.4 Adaptation to the terrestrial environment

The terrestrial environment for electronic news gathering and contribution is basically characterized by the influence of multi-path signals, operating with significant frequency errors introduced by Doppler shift, use of a low-cost, omnidirectional transmit antenna, operation with varying signal strengths and very low signal to noise ratios and environmental noise and other factors. Because audiovisual information is very critical for delivery over such environment, the transmission system used must provide sufficient performance that the influence of radio propagation channel is minimized. Considering that current terrestrial broadcasting transmission systems may provide such performance, the preferred option is for terrestrial electronic news gathering and contribution to re-use processing stages of terrestrial broadcasting systems. For this reason, coded Orthogonal Frequency Division Multiplex modulation (COFDM) has been chosen by many designers of digital ENG systems.

Terrestrial COFDM modulators are designed according to ETSI standards EN 300 744 (DVB-T) [15.12] and EN 302 755 [15.13] (DVB-T2). More details on performance of DVB-T and -T2 systems are provided in section 9.4 of this Handbook and in references [15.12, 15.13]. The European terrestrial technical standard for DVB-T [15.12] offers different levels of QAM modulation and inner code rates in 6, 7 or 8 MHz bandwidths to trade usable bit rate (for the video encoder) versus ruggedness of the link. As OB/ENG links are on the input or contribution side of a broadcast system, the highest bit-rate is preferred to minimize concatenation effects of multiple video encode/decode cycles through the broadcast chain. Hence a spectrum plan based on 8 MHz channels is preferred, providing a range of usable data rates from 4.976 Mbit/s to 31.668 Mbit/s by selection of bandwidth, guard interval, forward error correction and modulation type. Selection of forward error correction, modulation type and channel bandwidth may be used to trade ruggedness of the link versus usable bit rate. Adjacent 6/7/8 MHz channels may be combined into a wider channel to establish higher usable bit rate links for high definition video paths. For example, in case of 8 MHz in a 24 MHz channel, bit rates of up to 95.51 Mbit/s may be transmitted, or in a 32 MHz channel, rates exceeding 126.72 Mbit/s may be achieved. High definition video encoding systems utilizing MPEG-2 are widely available which produce a satisfactory video quality at these bit rates. However, more advanced coding techniques will lower the bit rates required for high definition links.

The DVB-T2 standard is also suitable for professional use, e.g. transmissions between radio cameras and mobile studios. For this purpose, a 10 MHz option is included; consumer receivers are not expected to support the 10 MHz mode.

Table 15.7 and Table 15.8 provide user requirements and the example of technical parameters for transmission of digital HDTV/SDTV using ENG systems when assigned in the fixed and mobile services [15.6], [15.7], [15.8]. Whilst in practice a range of operating parameters may be employed, these examples provide an indication of current system parameters.

For fixed operation and transmission from helicopters, single carrier QAM systems (ARIB STD-B11 [15.14]) are used. For mobile transmission and wireless camera systems, OFDM systems (ARIB STD-B33 [15.15]) are used. Each system has a postcard-sized HDTV compression encoder or decoder in it. System parameters for the HDTV/SDTV digital microwave links are shown in Table 15.9.

[15.15] defines a terrestrial OFDM digital transmission system for the Field Pick-up Unit (FPU), a kind of portable radio transmission equipment for television program contribution with fixed and mobile transmission. This standard is intended to apply only during the period when analogue and digital FPU systems are used together. Therefore, another standard may be specified when the digital system will be used alone in the future. [15.15] defines the use of concatenated coding with OFDM-PSK or OFDM-QAM modulations thus providing maximum transmission bit-rate up to 105 Mbit/s (in full mode with 18 MHz bandwidth).

TABLE 15.7

**User requirements and the example of technical parameters for transmission
of digital HDTV/SDTV signals in the fixed service**

Item		User requirements	Example of technical parameters
Latency		As short delay as possible	< 500 ms
Transmission bandwidth		8 MHz, 9 MHz, 18 MHz and 24 MHz	See Rec. ITU-R F.1777 [15.16]
Transmission power		1.76-7 dBW	
Frequency		6-7 GHz, 10 GHz and 13 GHz bands	
Antenna	Tx	0.6 m dish	Transmission distance: 6-7 GHz: 50-100 km (depending on necessary margin) 10 GHz: 7 km (with necessary rain margin) 13 GHz: 5 km (with necessary rain margin)
	Rx	0.6 m dish	
Modulation		Multi-QAM (16, 32, 64); QPSK-OFDM	See [15.16]
Transmission capacity		To support all the above transmission parameters	Up to 66 Mbit/s (depending on bandwidth and modulation, see [15.16])
Environmental reliability		System should be reliable in all possible environmental conditions (temperature, humidity, etc.)	Temperature: 0° to 50°C (outdoor units) 5° to 45°C (indoor units) Relative humidity: 95% non condensing
Ease of alignment		System should have built-in facility to generate certain test signals	Colour bar generator with 16 character identity
Size and weight		Small in size and light in weight for easy and quick operationalization	
Recording media		Should have facility to record using all accepted media types	Tapes; DVDs; Blu Ray discs and hard discs

TABLE 15.8

User requirements and the example of technical parameters for transmission of digital HDTV/SDTV signals in the mobile service

Item		User requirements	Example of technical parameters
Latency		As short delay as possible	< 500 ms
Transmission bandwidth		9 MHz, 18 MHz, 27 MHz and 80 MHz	See Rec. ITU-R M.1824 [15.17]
UHF	Transmission power	7 dBW	Transmission distance: 4 km
	Frequency	800 MHz band	
	Tx antenna	Co-linear	
	Rx antenna	Yagi	
Microwave	Transmission power	4 dBW, 7 dBW	Transmission distance: 4 km
	Frequency	6-7 GHz, 10 GHz and 13 GHz bands	
	Tx antenna	Horn, parabolic, helix	
	Rx antenna	0.3 m dish	
Airborne	Tx antenna	0.2 m dish	Transmission distance: 6-7 GHz: 50-65 km (depending on necessary margin) 10 GHz: 7 km (with necessary rain margin) 13 GHz: 5 km (with necessary rain margin)
	Rx antenna	1.2 m dish	
Modulation		Multi-QAM (16, 32, 64), QPSK-OFDM	See [15.17]
Transmission capacity		To support all the above transmission parameters	Up to 60 Mbit/s (depending on bandwidth and modulation, see [15.17])
Environmental reliability		System should be reliable in all possible environmental conditions (temperature, humidity etc.)	Temperature: 0° to 50°C (outdoor units) 5° to 45°C (indoor units) Relative humidity: 95% non condensing
Ease of alignment		System should have built-in facility to generate certain test signals for ease of alignment process	Colour bar generator with 16 character identity
Size and weight		Small in size and light in weight for easy and quick operationalization	

TABLE 15.9

System parameters for HDTV/SDTV digital terrestrial electronic news gathering (ARIB STD-B11 and B33)

Frequency band	800 MHz	5, 6, 7, 10 and 13 GHz			
ARIB standard	STD-B33	STD-B33	STD-B33	STD-B11	
Channel spacing	9 (SDTV)	9 (SDTV)	18 (HDTV)	18 (HDTV)	MHz
Capacity (payload)	Up to 16	Up to 30	Up to 60	Up to 66	Mbit/s
Modulation	QPSK-OFDM 16-QAM-OFDM 32-QAM-OFDM	QPSK-OFDM 16-QAM-OFDM 32-QAM-OFDM 64-QAM-OFDM		QPSK 16-QAM 32-QAM 64-QAM	Digital
Typical transmit antenna gain	5-10	29-35	29-35	29-35	dBi
Transmit feeder loss (min)	1	1	1	1	dB
Transmit antenna type	Collinear/Yagi	Parabolic	Parabolic	Parabolic	
Transmit power (max)	7	4	7	1.76	dBW
EIRP (max)	11-16	32-38	35-41	30-36	dBW
Typical receive antenna gain	10-15	29-35	29-35	29-35	dBi
Receive antenna type	Yagi	Parabolic	Parabolic	Parabolic	
Receive feeder loss (max)	1	1	1	1	dB
Receiver IF bandwidth	9	9	18	18	MHz
Receive noise figure	4	4	4	4	dB
Receiver thermal noise	-130.5	-130.5	-127.4	-127.4	dBW

Since the publication of [15.1], technology used for SAB/SAP has made significant technical progress. This has led to the use of new technologies for SAB/SAP:

- the introduction of digital video links, for both point-to-point and mobile links;
- the introduction of digital wireless microphones;
- the possibility to use in programme contribution public networks, like TETRA, GSM, UMTS, etc.

Technical parameters and other issues for such SAB/ SAP application in terrestrial environment is provided in Report ITU-R BT.2344-1 – Information on technical parameters, operational characteristics and deployment scenarios of SAB/SAP as utilized in broadcasting [15.9]. Additional extended information for audio SAB/SAP links is provided in Report ITU-R BT.2338-0 – Services ancillary to broadcasting/services ancillary to programme making spectrum use in Region 1 and the implication of a co-primary allocation for the mobile service in the frequency band 694-790 MHz [15.10]. Information on frequencies and tuning ranges that are used in different ITU-R administrations is provided in [15.1] and [15.11].

15.2.5 Satellite assistance to contribution and programme production for ENG applications

As part of an ENG system, satellite transponders can be used to deliver a broadcast-quality signal (up to UHD TV) in regional, national and international television broadcasts from an event location. The transmission in such systems is called satellite news gathering (SNG) and is usually organized as a “point-to-point” or “point-to-multipoint” system (usually the connection is established between the studio and OB van with a mobile satellite earth station) with the delivery of broadcast content and control/coordination signals.

SNG transmissions uses broadcast systems (e.g. DVB-S system [15.20]), a specific standard for satellite news gathering (such as, for example, DVB-DSNG [15.21]) or a special configuration of broadcast systems (e.g. the DVB-S2 system with its DSNG (S2) configuration [15.22]). The recent trend is transition to universal (generic) solutions that can be used for the transmission of broadcast and professional applications, internet access, etc.

This allows a shared eco-system to be created with the possibility of interaction between the individual variants of the system (for example for interactive television). However, the other two solutions (first generation broadcast standards DVB-S, ISDB-S, etc. as well as professional satellite news gathering system) are still widely used.

SNG systems impose specific requirements, including the following:

- The need to establish a reliable “point to point” or “point-to-multipoint” link in any place at any time to transmit television program content in Standard, High or Ultra-High Definition with corresponding sound;
- The need for organization of bi-directional channels for coordination and control data;
- Portability and mobility of equipment with a minimum number of staff.

Table 15.10 shows the example of the technical characteristics of digital news gathering with possible parameters of transmission and also features of transmitted television signals.

TABLE 15.10

**Comparative analysis of technical performance for satellite news gathering standards
DVB-DSNG, DVB-DSNG (S2) and DVB-DSNG (S2X)**

Parameter	Digital news gathering		
	DVB-DSNG	DVB-DSNG (S2)	DVB-DSNG (S2X)
Channel encoding and modulation			
Input stream format	Transport Stream	Transport Stream, Generic Encapsulated Stream	
Modulation	QPSK, 8PSK, 16QAM	QPSK, 8PSK, 16APSK, 32APSK	QPSK, 8PSK, 16APSK, 32APSK, 64APSK, 128APSK, 256APSK
Channel encoding/ modulation mode	Constant Coding and Modulation	Constant Coding and Modulation, Variable Coding and Modulation, Adaptive Coding and Modulation	
Length of the processed data block	188 byte packets, including 1 synchronization byte, 3-byte header and 184 bytes of payload	Frame consists of a payload with length 64 800 or 16 200 bits and header (80 bits)	
Outer encoding	Outer Reed-Solomon code RS (204,188, 8), which is obtained by shortening the mother code RS (255, 239, 8)	BCH code with the ability to correct 8 to 12 erroneous symbols	BCH code
Inner encoding	Convolutional code	LDPC	
Code rate	1/2, 2/3, 3/4, 5/6, 7/8	LDPC rate: 1/4, 1/3, 2/5, 1/2, 3/5, 2/3, 3/4, 4/5, 5/6, 8/9, 9/10	LDPC rate: 1/4, 1/3, 2/5, 1/2, 3/5, 2/3, 3/4, 4/5, 5/6, 8/9, 9/10, 5/9, 7/9, 9/20, 13/45, 11/20, 23/36, 25/36, 13/18, 26/45, 28/45, 77/90, 8/15, 32/45, 11/15, 29/45, 31/45
Channel correction	Equalizer	Pilots	
Channel bandwidth, MHz	1.5-72		
Usage of the transponder frequency band	Transponder with frequency (FDM) and time (TDM) divisions of channels		

TABLE 15.10 (end)

Parameter	Digital news gathering		
	DVB-DSNG	DVB-DSNG (S2)	DVB-DSNG (S2X)
Required BER at the output of the internal decoder	$BER \approx 2 \times 10^{-4}$	$BER \approx 1 \times 10^{-7}$	
Roll-off coefficient	$\alpha = 0, .25; \alpha = 0.35$	$\alpha = 0.2; \alpha = 0.25; \alpha = 0.35$	$\alpha = 0.05, \alpha = 0.15, \alpha = 0.1$
Signal-To-Noise Ratio, dB	4.5..10.7	-2.35..16.05	-2.85..19.57
Video/Audio Compression (collected examples)			
Resolution level	SDTV		HDTV
Resolution	720×576, 704×576, 640×576, 576×576, 544×576, 576×528, 576×352, 352×288, 320×288, 352×240, 320×240		1920×1080i/25, 1440×1080i/25, 1280×1080i/25, 960×1080i/25, 1280×720p/50, 960×720p/50, 720×640p/50
MPEG compression configuration	MPEG-2 MP @ ML; MPEG-4/AVC MP@L3		MPEG-2 422P @ ML MPEG-4 AVC HP@L4
Video bit-rate, Mbit/s	1..15 (MPEG-2 MP @ ML) 1..10 (MPEG-4/AVC MP@L3)		1.5...30 (50 for 4:2:2) (MPEG-2 422P @ ML) 1..25 Mbit/s (MPEG-4 AVC HP@L4)
Chroma sampling	4:2:2		4:2:0/4:2:2
Audio mode	Mono/ stereo		
Number of audio channels	Up to 8 channels		
Audio compression	MPEG-1 Layer II; Dolby Digital® (AC-3) 2.0; Dolby Digital® (AC-3) 1 – 5.1; MPEG-2 AAC-LC; MPEG-4 HE-AAC		
Audio bit-rate	64...256 kbit/s		

Other parameters for SNG are defined in [15.20], [15.21] and [15.22].

Bibliography to Chapter 15

- [15.1] **ITU-R**, Report ITU-R BT.2069, *Tuning ranges and operational characteristics of terrestrial electronic news gathering (ENG), television outside broadcast (TVOB) and electronic field production (EFP) systems*
- [15.2] **ITU-R**, Recommendation ITU-R BT.1868, *User requirements for codecs for transmission of television signals through contribution, primary distribution and SNG networks*
- [15.3] **ITU-R**, Recommendation ITU-R BS.1548, *User requirements for audio coding systems for digital broadcasting*
- [15.4] **ITU-R**, Recommendation ITU-R BT.1203, *User requirements for generic video bit-rate reduction coding of digital TV signals for an end-to-end television system*
- [15.5] **ITU-T**, Recommendation ITU-T H.265, *High Efficiency Video Coding*
- [15.6] **ITU-R**, Recommendation ITU-R BT.1872, *User requirements for digital electronic news gathering*

- [15.7] **ITU-R**, Recommendation ITU-R BT.800-2, *User requirements for the transmission through contribution and primary distribution networks of digital television signals defined according to the 4:2:2 standard of Recommendation ITU-R BT.601 (Part A)*
- [15.8] **ITU-R**, Recommendation ITU-R BT.1121-1, *User requirements for the transmission through contribution and primary distribution networks of digital HDTV signals*
- [15.9] **ITU-R**, Report ITU-R BT.2344-1, *Information on technical parameters, operational characteristics and deployment scenarios of SAB/SAP as utilized in broadcasting*
- [15.10] **ITU-R**, Report ITU-R BT.2338-0, *Services ancillary to broadcasting/services ancillary to programme making spectrum use in Region 1 and the implication of a co-primary allocation for the mobile service in the frequency band 694-790 MHz*
- [15.11] **ERC** Recommendation 25-10 – *Frequency ranges for the use of temporary terrestrial audio and video SAP/SAB links (incl. ENG/OB)*
- [15.12] **ETSI** EN 300 744 – *Digital Video Broadcasting (DVB); Framing structure, channel coding and modulation for digital terrestrial television*
- [15.13] **ETSI** EN 302 755 – *Digital Video Broadcasting (DVB); Frame structure, channel coding and modulation for a second generation digital terrestrial television broadcasting system (DVB-T2)*
- [15.14] **ARIB** STD-B11 Version 2.1 – *Portable microwave digital transmission system for television programme contribution*
- [15.15] **ARIB** STD-B33 Version 1.0 – *Portable OFDM digital transmission system for television programme contribution*
- [15.16] **ITU-R**, Recommendation ITU-R F.1777, *System characteristics of television outside broadcast, electronic news gathering and electronic field production in the fixed service for use in sharing studies*
- [15.17] **ITU-R**, Recommendation ITU-R M.1824, *System characteristics of television outside broadcast, electronic news gathering and electronic field production in the mobile service for use in sharing studies*
- [15.18] **ITU-R**, Recommendation ITU-R BT.1380-1, *Standards for bit rate reduction coding systems for SDTV*
- [15.19] **ITU-R**, Recommendation ITU-R BT.1737, *Use of the ITU-T Recommendation H.264 (MPEG-4/AVC) video source-coding method to transport high definition TV programme material*
- [15.20] **ETSI** EN 300 421 – *Digital Video Broadcasting (DVB); Framing structure, channel coding and modulation for 11/12 GHz satellite services*
- [15.21] **ETSI** EN 301 210 – *Digital Video Broadcasting (DVB); Framing structure, channel coding and modulation for Digital Satellite News Gathering (DSNG) and other contribution applications by satellite*
- [15.22] **ETSI** EN 302 307 – *Digital Video Broadcasting (DVB); Second generation framing structure, channel coding and modulation systems for Broadcasting, Interactive Services, News Gathering and other broadband satellite applications (DVB-S2)*
- [15.23] **ITU-R**, Recommendation ITU-R BT.1871, *User requirements for wireless microphones*
- [15.24] **Alberico, Gino and Airola Gnota, Daniele** – RAI-Radiotelevisione Italiana, R&D Department – 4K vision. – DVB SCENE Edition No.33 March 2010.
- [15.25] **ITU-R**, Report ITU-R BT.2246-5, *The present state of ultra-high definition television*

List of Abbreviations

3DTV	Three Dimensional Television
3G	Third Generation of Mobile systems
4G	Fourth Generation of Mobile systems
A/V	Audio Visual
ABNT	Associação Brasileira de Normas Técnicas
AC3	Audio Coding 3
ACAP-X	Advanced Common Application Platform composed of XHTML markup, style rules, scripts and embedded graphics, video and audio.
ACM	Adaptive Coding and Modulation
AFD	Active Format Descriptor
AL-FEC	Application Layer Forward Error Correction
APSK	Amplitude and phase-shift keying
ARIB	Association of Radio Industries and Businesses (Japan)
AS11-DPP	Application Specification AS-11 Digital Production Partnership (DPP)
ASEAN	Association of Southeast Asian Nations
ASI	Asynchronous Serial Interface
ASK	Amplitude-shift keying
ASMG	Arab Spectrum Management Group
ASO	Analogue switch off
ATSC	Advanced Television Systems Committee
ATSC-M/H	Advanced Television Systems Committee Mobile / Handheld
ATTC	Advanced Television Test Center
ATU	African Telecommunication Union
ATV	Advanced Television
AVC	Advanced Video Coding
AVS	Audio Video Standard
AWGN	Additive white Gaussian noise
BB	Baseband
BBC	British Broadcasting Corporation
BCH	Bose, Chaudhuri, and Hocquenghem codes
BER	Bit Error Rate
BLER	MPEG Block Error Ratio
BML	Broadcast Mark-up Language
BPSK	Binary Phase Shift Keying
BR	ITU Radiocommunication Bureau
BRIFIC	International Frequency Information Circular of the Radiocommunication Bureau
BS	Broadcasting Service
BSS	Broadcasting Satellite Service
BST-OFDM	Band-segmented transmission OFDM

C/N	Carrier to Noise Ratio
CA	Conditional Access
CAM	Control Access Module
CAS	Conditional Access System
CAT	Conditional Access Table
CBR	Constant bit-rate
CCM	Constant Coding and Modulation
CEA	Consumer Electronics Association (now renamed Consumer Technology Association (CTA))
CENELEC	European Committee for Electrotechnical Standardization
CEPT	European Conference of Posts and Telecommunications
CI	Common Interface
CICAM	Common Interface Conditional Access Module
CIR	Channel Impulse response
COFDM	Coded Orthogonal Frequency Division Multiplexing
CPCM	Content Protection and Copy Management
CRC	Cyclic Redundancy Check
CSA	DVB Common Scrambling Algorithm
DASH	Dynamic Adaptive Streaming over HTTP
DBPSK	Differential Binary Phase Shift Keying
DECT	Digital Enhanced Cordless Telecommunications
DFL	Data Field Length
DRM	Digital Rights Management
DSCQS	Double stimulus continuous quality-scale
DSI	DownloadServerInitiate message
DSIS	Double stimulus impairment scale
DSL	Digital Subscriber Line
DSM-CC	Digital storage media command and control
DSNG	Digital Satellite News Gathering
DTMB	Digital Terrestrial Multimedia Broadcast
DTMB-A	Digital Terrestrial Multimedia Broadcast-Advanced
DTS	Decoding Time Stamp
DTS	DTS is the audio format of the company DTS (Dedicated To Sound)
DTTB	Digital Terrestrial Television Broadcasting
DTV	Digital Television
DVB	Digital Video Broadcasting
DVB-H	Digital Video Broadcasting – Handheld
DVB-RCT	Digital Video Broadcasting – Return Channel Terrestrial
DVB-S	Digital Video Broadcasting – Satellite
DVB-S2	Digital Video Broadcasting – Satellite second generation
DVB-SH	Digital Video Broadcasting – Satellite services to Handhelds

DVB-T	Digital Video Broadcasting-Terrestrial
DVB-T2	Digital Video Broadcasting-Terrestrial second generation
DVB-T2 Lite	Digital Video Broadcasting-Terrestrial second generation Lite Profile
DVD	Digital versatile disc or digital video disc
EACO	East African Communications Organization
EBU	European Broadcasting Union
EC	European Commission
ECOWAS	Economic Community Of West African States
EICTA	European ICT Industry Association, became DIGITALEUROPE
eMBMS	Evolved Multimedia Broadcast Multicast Service
ENG	Electronic News Gathering
EPG	Electronic Programme Guide
ERM	Electromagnetic compatibility and Radio spectrum Matters (cf. ETSI)
ES	Elementary stream
ESO	European Standardization Organization
ETSI	European Telecommunication Standardization Institute
FCC	Federal Communications Commission
FDM	Frequency Division Multiplex
FDP	File Delivery Protocol
FEC	Forward Error Correction
FEF	Future Extension Frames
FFT	Fast Fourier Transform
FLUTE	File Delivery Over Unidirectional Transport
FOBTV	Future of Broadcasting Television
FPU	Field Pick-Up Unit
FR	Full Reference
FS	Fixed Service
FSS	Fixed Satellite Service
GE06	Geneva Regional Agreement 2006
GEM	Globally Executable MHP
GI	Guard Interval
GS	Generic stream
GSE	Generic Stream Encapsulation
GSM	Global System for Mobile communications
GSO	Geostationary orbit
HBB4ALL	Hybrid Broadcast Broadband For ALL
HbbTV	Hybrid Broadcast-Broadband Television
HDR	Higher Dynamic Range
HD-SDI	High Definition Serial Digital Interface
HDTV	High Definition Television

HE-AAC	High-Efficiency Advanced Audio Coding
HEVC	High Efficiency Video Coding
HFR	Higher Frame Rate
Hi422P	High 4:2:2 Profile
Hi444P	High 4:4:4 Profile
HL	High Layer
HP	High Profile
HTML	HyperText Markup Language
IBB	Integrated Broadcast Broadband
ICIT	IPMP Control Information Table
iDTV	integrated digital television
IEC	International Electrotechnical Commission
IF	Intermediate Frequency
IF-x	InterFace number x in the broadcasting chain
IHDN	In-Home Digital Network
IMSC1	Internet Media Subtitles and Captions 1.0
IMT	International Mobile Telecommunication
INT	IP/MAC Notification Table
IP	Internet protocol
IPMP	Intellectual Property Management and Protection
IPTV	Internet protocol Television
IRD	Integrated Receiver-Decoder
ISDB-S	Integrated Services Digital Broadcasting – Satellite
ISDB	Integrated Services Digital Broadcasting
ISDB-T	Integrated Services Digital Broadcasting – Terrestrial
ISDN	Integrated Services Digital Network
ISED	Innovation, Science and Economic Development (Canada)
ISO	International Organization for Standardization
ITU	International Telecommunication Union
ITU-D	International Telecommunication Union – Development Sector
ITU-R	International Telecommunication Union – Radiocommunication Sector
ITU-T	International Telecommunication Union – Telecommunication Standardization Sector
LAN	Local Area Network
LCD	Liquid Crystal Display
LDPC	low-density parity-check code
LFE	low frequency effects
LMDS	Local Multipoint Distribution Service
LPDC	Low-Density Parity-Check
LSDI	Large-Screen Digital Imagery
LTE	Long Term Evolution

M/H	Mobile/Handheld
MAC	Media access control
MBLER	MPEG Macroblock Error Ratio
MERCOSUR	Mercado Común del Sur
MFN	Multi-Frequency Network
MFU	Media fragment unit
MHP	Multimedia Home Platform
MIFR	Master International Frequency Register
MIMO	Multiple-Input, Multiple-Output
MISO	Multiple Input, Single Output
ML	Main Layer
MMT	MPEG Media Transport
MMTP	MMT protocol
MP	Main Profile
MPE	Multi-protocol encapsulation
MPEG	Moving Pictures Expert Group
MPQM	Moving Pictures Quality Metric
MPU	Media Processing Unit
MS	Mobile Service
MSS	Mobile Satellite Service
MSS-ATC	(MSS – Ancillary Terrestrial Component)
MSTV	Association for Maximum Service Television
MUFS	Minimum Useable Field Strength
NAB	National Association of Broadcasters (USA)
NEDDIF	North East Digital Dividend Implementation Platform
NIT	Network Information Table
Nordig	Digital TV platform for the Nordic region and Ireland
NQM	Noise Quality Measure
NR	Nordstrom-Robinson
NR	No reference
NRT	Non Real-Time
NTIA	National Telecommunications and Information Administration (USA)
OB	Outside Broadcast
OFDM	Orthogonal Frequency Division Multiplexing
OIPF	Open IPTV Forum
OSI	Open Systems Interconnection
OTT	Over the Top (TV streaming over the Internet)
PAL	Phase Alternating Line (Analogue TV system)
PAT	Programme Association Table
PCM	Pulse-code modulation

PCR	Program Clock Reference
PDH	Plesiochronous Digital Hierarchy
PES	Packetized elementary stream
PID	Packet identifier
PLC	Power Line Communication
PLP	Physical Layer Pipe
PMSE	Programme Making and Special Events
PMT	Programme Map Table
PN	Pseudo-random Noise
PP	Pilot Pattern
PS	Programme streams
PSI	Programme-Specific Information
PSNR	Peak-Signal-to-Noise-Ratio
PSTN	Public switched telephone network
PTS	Presentation Time Stamp
PVR	Personal Video Recorder
PxER	Pixel Error Ratio
QAM	Quadrature Amplitude Modulation
QC	Quality Control
QoS	Quality of Service
QPSK	Quadrature Phase Shift Keying
RAI	Radiotelevisione Italiana
RAVIS	Real-time Audio-Visual Information System
RF	Radio Frequency
RF	Reduced reference
RN	Reference Network
ROHC	Robust Header Compression
ROO	Rules of operations
RPC	Reference Planning Configuration
RRC	Regional Radiocommunication Conference
RS	Reed Solomon (code)
RTP	Real-time Transport Protocol
Rx	Receiver
S/PDIF	Sony/Philips Digital Interface Format
SAB	Services Ancillary to Broadcasting
SADC	Southern African Development Community
SAP	Services Ancillary to Programme-making
SAT/IP	Satellite over IP
SBTVD	Sistema Brasileiro de Televisão Digital
SCART	Syndicat des Constructeurs d'Appareils Radiorécepteurs et Téléviseurs – Video Connector

SDH ATM	Synchronous Digital Hierarchy – Asynchronous Transfer Mode
SDR	Software Defined Radio
SDSCQE	Simultaneous double stimulus for continuous evaluation method
SDT	Service Description Table
SDTV	Standard Definition Television
SECAM	Séquentiel Couleur à Mémoire (Analogue TV system)
SEDDIF	South East Digital Dividend Implementation Platform
SES	Satellite Earth Stations and Systems
SFN	Single Frequency Network
SI	Service Information
SIMO	Single-Input, Multiple-Output
SLER	MPEG Slice Error Ratio
SNG	Satellite News Gathering
SRD	Short Range Devices
SRM	System Renewability Message
SS	Single-stimulus
SSCQE	Single stimulus continuous quality evaluation
SSD	Solid State Drive/Solid State Disc
SSIM	Structural Similarity Index
STB	Set-Top Box
STD	Standard
SVC	Scalable Video Coding
TDM	Time Division Multiplex
T-DMB	Terrestrial – Digital Multimedia Broadcasting
TDS-OFDM	Time-Domain Synchronous OFDM
TER	Timing Error Ratio
TETRA	Terrestrial Trunked Radio
TFS	Time-Frequency Slicing
THD	Total Harmonic Distortion
TIES	Telecommunication Information Exchange Service (ITU)
TLV	Type-length value
TMCC	Transmission and Multiplexing Configuration Control
TS	Transport stream
TSDT	Transport Stream Description Table
TTML	Timed Text Markup Language
Tx	Transmitter
UHDTV	Ultra-High Definition Television
UHF	Ultra-High Frequency
ULE	Unidirectional lightweight encapsulation
UMTS	Universal Mobile Telecommunication System

UNCRPD	United Nations Convention on the Rights of Persons with Disabilities
UP	User packets
UPL	User packet length
UPnP	Universal Plug and Play
URI	Usage Rules Information
U-U	User-User
UWB	Ultra Wide Band
VBR	Variable bit-rate
VCM	Variable Coding and Modulation
VCR	Video Cassette Recorder
VFDR	Video Frame Decoding Ratio
VFLR	Video Frame Loss Ratio
VHF	Very High Frequency
VQEG	Video Quality Experts Group
VQM	Video Quality Metric
VSAT	Very Small Aperture Terminal
VSB	Vestigial Side Band
W3C	World Wide Web Consortium
WEDDIP	Western European Digital Dividend Implementation Platform
WLAN	Wireless Local Area Network
WRC	World Radiocommunication Conference
WSD	White Space Devices
WSS	Wide Screen Signalling
XML	EXtensible Markup Language
YPbPr	Luminance (Y) and differential colour coded video (Y minus Red, Y minus Blue).

International
Telecommunication
Union
Place des Nations
1211 Geneva 20
Switzerland

ISBN 978-92-61-23481-2 SAP id



Printed in Switzerland
Geneva, 2016
Photo credits: Shutterstock